

34', 41', 46' & 53' SUPERROLLER

34', 41', 46' & 53' SUPERROLLER

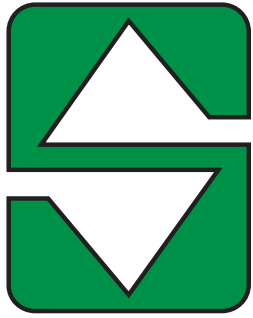

# SUMMERS®

## Operator's Manual

# 34', 41', 46' & 53' TRAIL-TYPE SUPERROLLER

### IMPORTANT

THE OPERATOR IS RESPONSIBLE FOR ADJUSTING THE MACHINE SINCE MACHINE DOES NOT COME "FIELD READY" FROM FACTORY.



### CAUTION

READ & UNDERSTAND OPERATOR'S MANUAL BEFORE USING MACHINE.

*See [www.summersmfg.com](http://www.summersmfg.com) for latest version of all Summers Operator's Manuals.*

**SUMMERS MANUFACTURING CO., INC.**

**WEB SITE: [www.summersmfg.com](http://www.summersmfg.com)**

DEVILS LAKE, NORTH DAKOTA 58301..... (701) 662-5391

# Warranty

Summers warrants only products of its manufacture against operational failure caused by defective materials or workmanship which occur during normal use within 36 months from the date of purchase by the end user from Summers' dealer.

Summers' obligation is to replace free of charge any part of any product that Summers inspection shows to be defective excluding transportation charges to Devils Lake, ND and return and also excluding all transportation costs from Summers' dealer to the dealer's customer and all other costs such as removal and installation expense.

Summers shall not be liable for loss of time, manufacturing costs, labor, material, loss of profits, consequential damages, direct or indirect, because of defective products whether due to rights arising under the contract of sale or independently thereof, and whether or not such claim is based on contract, tort or warranty.

Written permission for any warranty claim return must be first obtained from authorized Summers' personnel. All returns must be accompanied with a complete written explanation of claimed defects and the circumstances of operational failure.

Written warranty for all component parts used in the manufacture of Summers products is available upon request. Warranty of such component parts will be determined by said component manufacturer upon their inspection of the claimed defective part.

This express warranty is the sole warranty of Summers. There are no warranties, which extend beyond the warranty herein expressly set forth. The sales for products of Summers under any other warranty or guarantee express or implied is not authorized. This warranty voids all previous issues.

**SUMMERS MANUFACTURING CO. INC.**  
**DEVILS LAKE, NORTH DAKOTA 58301**

1/16

# INTRODUCTION

This manual provides the following information about your Summers Land Roller.

## SECTION CONTENTS

- Section 1 – SAFETY explains important safety precautions and familiarizes the Operator with the decals and their locations.
- Section 2 – ASSEMBLY includes step by step assembly instructions for your Summers Land Roller.
- Section 3 – LAND ROLLER OPERATION provides necessary information for the operation and adjustment of the machine.
- Section 4 – MAINTENANCE covers recommended mechanical maintenance. TROUBLESHOOTING provides a quick reference to solving problems. SPECIFICATIONS lists important dimensions, capacities and other technical information.
- Section 5 – PARTS

## OTHER ITEMS OF IMPORTANCE

- A. Summers Mfg. Co., Inc. strongly recommends that each Land Roller Operator **READ and UNDERSTAND** the Operator's Manual before using the machine. In addition, this Operator's Manual should be **REVIEWED at least ANNUALLY** thereafter.
- B. It is the policy of this company in improve its products whenever possible and practical to do so. We reserve the right to make changes or improvements in the design or construction of parts at any time without incurring obligations to install such changes on products previously delivered.
- C. Reference to "right" and "left" in this manual is determined when machine is viewed from the rear.
- D. Parts are referenced in each drawing with the Summers Manufacturing Part Number. Use this Part Number when ordering replacement parts from your Summers dealer. See back section of manual for description of each Part Number.
- E. **WARNING – DO NOT ATTEMPT** to raise machine into transport position if mud has built up on rollers or if machine weight has been increased by any other means. Mechanical failure may occur.
- F. Ability to safely operate the Summers Superroller is determined by both tractor horsepower and weight. The minimum tractor weight for operating this implement is 20,000 lb. Minimum tractor engine horsepower is 180. Dual tires or single tires set at maximum width are required for safe operation of Land Roller.
- G. Never tow this implement with less than an 20,000 lb. vehicle. Tongue weight in transport and field positions is 1150 lbs.
- H. **NEVER ALLOW** anyone to work under Land Roller.



Scan code to the right for the latest version of all Summers Operator's Manuals.

<u>OWNER REGISTER</u>	
Name _____	Size _____
Address _____	Serial Number _____ <small>(located by the hitch piece)</small>
City _____	Date Purchased _____
State/Prov. _____	Dealer _____
Mail Code _____	

# **TABLE OF CONTENTS**

## **SECTION 1 – SAFETY**

Safety-Alert Symbol.....	1-1
General Safety Practices.....	1-1
Safety During Transport.....	1-2
Safety Decals .....	1-2
Decals and Their Locations .....	1-2-1-6

## **SECTION 2 – ASSEMBLY**

General Assembly Safety Instructions.....	2-1
Safety Alert Symbol .....	2-1
General Safety Practices.....	2-2
Set-Up of Frame .....	2-3 – 2-11
Hydraulic Set-Up .....	2-12
Wiring & Safety Light Installation.....	2-13

## **SECTION 3 – LAND ROLLER OPERATION**

Land Roller Operation Safety .....	3-1
Steps Prior to Operation .....	3-1
Initial Hookup.....	3-2
Steps Required to Unfold from Transport to Field Position .....	3-3
Field Operation .....	3-4
Steps Required to Fold from Field to Transport Position.....	3-4
Transporting .....	3-5
Unhooking Land Roller From Tractor .....	3-6

## **SECTION 4 – MAINTENANCE**

Maintenance Safety.....	4-1
Maintenance for after the First Day Four Hours of Operation .....	4-1
Daily and Periodic Maintenance .....	4-1
Storage & Specifications .....	4-2

## **SECTION 5 – PARTS**

Center Frame .....	5-2
Hitch .....	5-3
Center Transport.....	5-4
Wing .....	5-5
Wing Transport .....	5-6
Decal Locations .....	5-7
Hub and Axle Components.....	5-8
Hydraulics.....	5-9
Safety Lights.....	5-10
Acre Meter Option .....	5-11
Part Numbers .....	5-12 – 5-16

# TRANSPORT SAFETY

1. Road speed should not exceed 20 mph (32 km/hr).



2. Do not tow if the implement's towing vehicle ratio is greater than 1.5:1. See Specifications Section for implement weights.
3. If more than one implement is to be pulled by a towing vehicle, it is recommended that each implement is to be a maximum of 50% of the weight of the preceding implement. If it is not possible to reach this weight limit, transport the implements separately.
4. When approaching rough roads/ground (such as entering a road), slow down to a safe driving speed.
5. Check all lights and reflectors to ensure ALL regulations are met. Make sure the SMV emblem is attached to the implement and is clearly visible from the rear.



SMV emblems are only attached to vehicles traveling slower than 25 mph (40 km/hr). The most hazardous conditions to drive in are a daybreak and dusk. The use of a pilot car is recommended.

6. Always install ALL safety locks before transporting an implement.
7. Always park implements on a firm, level surface.

## SECTION 1 - SAFETY

---

### SAFETY-ALERT SYMBOL



This symbol is used to denote possible danger and care should be taken to prevent bodily injury. This symbol means:

### **ATTENTION! BECOME ALERT!** **YOUR SAFETY IS INVOLVED!**

Definition of each **Signal Word** used in conjunction with the **Safety-Alert** symbol.



indicates an imminently hazardous situation which, if not avoided, will result in death or serious injury. This signal word is limited to the most extreme situations.



indicates a potentially hazardous situation which, if not avoided, could result in death or serious injury.



indicates a potentially hazardous situation which, if not avoided, may result in minor or moderate injury. It may also be used to alert against unsafe practices.

### **GENERAL SAFETY PRACTICES**

1. READ AND UNDERSTAND Operator's Manual before using machine. Review at least annually thereafter.
2. VERIFY all safety devices and shields are in place before using machine.
3. KEEP hands, feet, hair and clothing away from moving parts.
4. STOP engine, place all controls in neutral, set parking brake, remove ignition key and wait for all moving parts to stop before servicing, adjusting, maintaining or unplugging.
5. BE CAREFUL when working around high pressure hydraulic system.
6. ALWAYS make sure Land Roller is lowered into field position (cylinders retracted), it is blocked to prevent movement and that pressure is relieved from hydraulic circuits before servicing.
7. DO NOT ALLOW RIDERS.
8. USE EXTREME CARE when making adjustments.
9. KEEP CHILDREN AWAY from machinery at all times.
10. NEVER ALLOW anyone to work under Land Roller.
11. WARNING – DO NOT ATTEMPT to raise machine into transport position if mud has built up on rollers or if machine weight has been increased by any other means. Mechanical failure may occur.

## SECTION 1 - SAFETY

### SAFETY DURING TRANSPORT

1. Ability to safely operate the Summers Superroller is determined by both tractor horsepower and weight. The minimum tractor weight for operating this implement is 20,000 lbs. Minimum tractor engine horsepower is 180. Dual tires or single tires set at maximum width are required for safe operation of Land Roller.
2. ONLY TOW at a safe speed – 20 MPH MAXIMUM. Use caution when making corners and meeting traffic.
3. USE Safety Lights and Safety Chain between tractor drawbar and implement hitch when transporting on public roads.
4. ALWAYS install lift cylinder locks before transporting on public roads.
5. FOLLOW ALL local laws governing transporting of farm machinery.
6. Use additional caution and reduce speed when towing under adverse conditions, when turning and when on unlevel surfaces.
7. Frequently check for traffic from rear, especially during turns.

### SAFETY DECALS

1. KEEP SAFETY DECALS CLEAN.
2. REPLACE missing or unreadable decals. New decals are available from your Summers dealer by ordering correct part number (PN) located on the decal.

### DECALS AND THEIR LOCATIONS

#### 1. PN 8Z0075 – DECAL FOR REMOVING TRANSPORT LOCKS

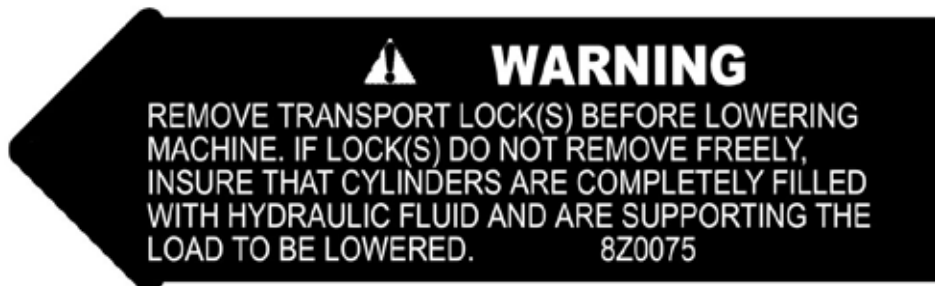

#### 2. PN 8Z0087 – DECAL FOR PINCH POINT HAZARD

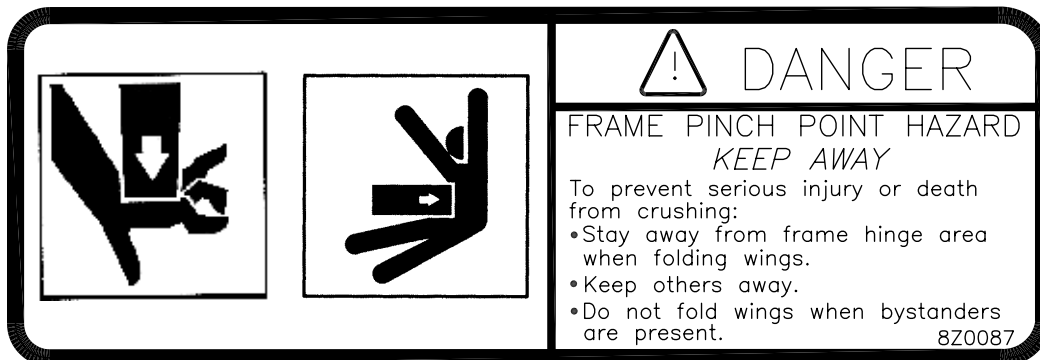

SECTION 1 - SAFETY

3. PN 8Z0202 & 8Z0204 – SUPERROLLER ID DECALS



4. PN 8Z0276 – DECAL FOR GENERAL CAUTION

	<p> <b>CAUTION</b></p>
<ol style="list-style-type: none"><li>1. Read and understand Operator's Manual before using machine.</li><li>2. For Sprayers:<ol style="list-style-type: none"><li>a. Read and follow chemical manufacturers' WARNINGS, instructions and procedures before using.</li><li>b. Use recommended personal protective equipment to reduce or eliminate chemical contact.</li><li>c. Never run pump dry.</li></ol></li><li>3. Verify all safety devices and shields are in place before using machine.</li><li>4. Keep hands, feet, hair and clothing away from moving parts.</li><li>5. Stop engine, place all controls in neutral, set parking brake, remove ignition key and wait for all moving parts to stop before servicing, adjusting, maintaining or unplugging.</li><li>6. Be careful when working around high pressure hydraulic system.</li><li>7. Do not allow riders.</li><li>8. Check all wheel bolts DAILY for tightness.</li><li>9. Refer to Operator's Manual for periodic and annual maintenance.</li><li>10. For Towed Implements; DO NOT EXCEED 20 MPH.</li></ol>	
<p>8Z0276</p>	

5. PN 8Z0800 – AMBER REFLECTOR

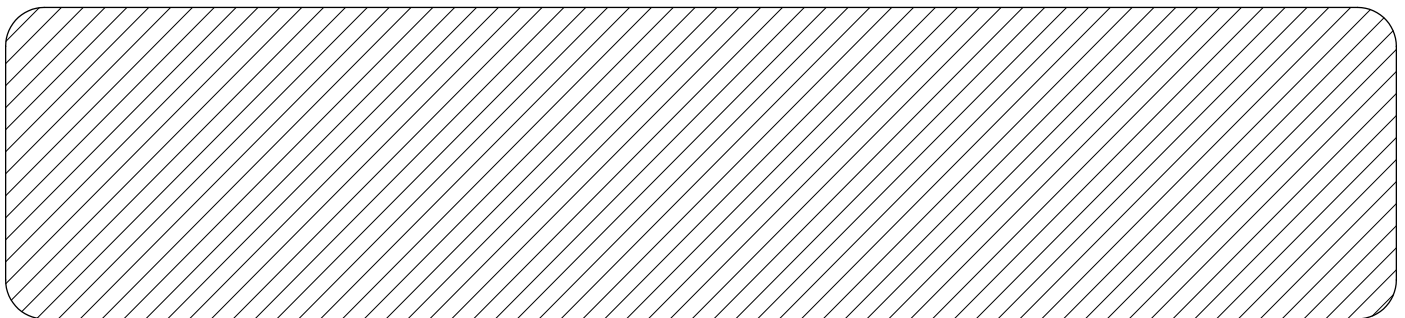



## SECTION 1 - SAFETY

---

### 6. PN 8Z0805 – RED-ORANGE REFLECTOR

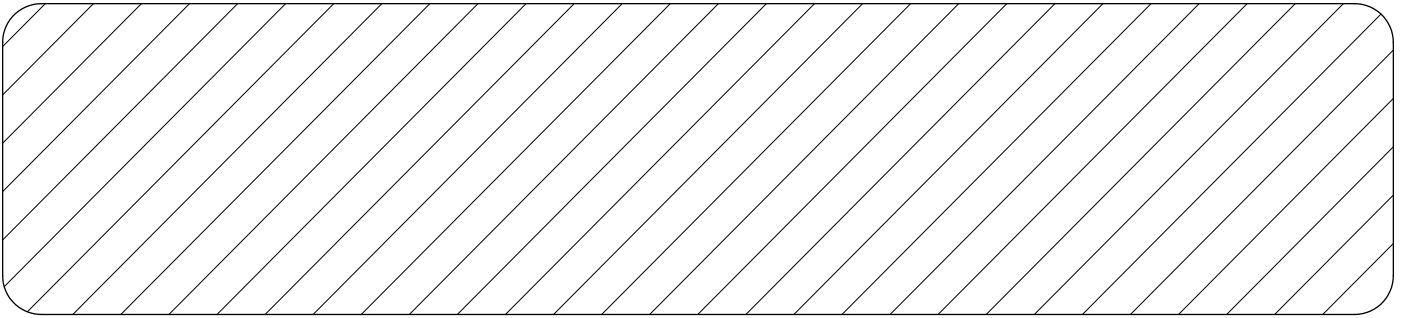

### 7. PN 8Z0810 – RED REFLECTOR

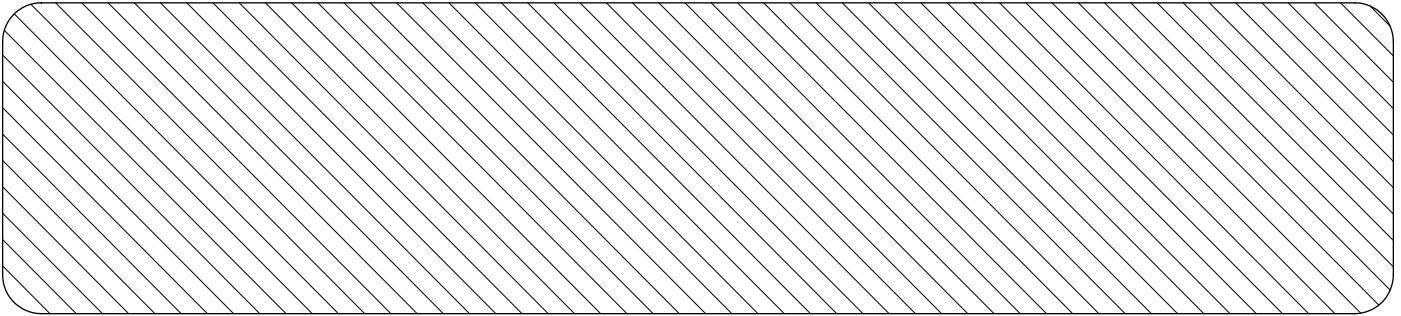

### 8. PN 8Z2200 – RT8430 DECAL

**RT8430**

### SAFETY LIGHT OPERATION

The Summers Safety Light Kit is equipped with a 7 pin connector which meets SAE J560 specification. To protect 7 pin connector, store in dust cap (8K8067) when not attached to towing vehicle.

*On most towing vehicles WITHOUT brake lights:*

Amber lights will turn on with flashers or turn signals.

Red lights will turn on with parking, road or field lights.

*On most towing vehicles WITH brake lights:*

Amber lights will turn on with flashers, turn signals OR when brake is applied.

Red lights will turn on with parking or road lights.



**SECTION 1 - SAFETY**

---

**GENERAL ASSEMBLY SAFETY PRACTICES**

1. READ AND UNDERSTAND Operator's Manual before assembly of machine.
2. If machine is to be assembled INDOORS, check that exit door is a MINIMUM OF 14' WIDE and a MINIMUM of tractor height.
3. Reference to "RIGHT" and "LEFT" is determined when machine IS VIEWED FROM THE REAR.
4. Reference to "FORWARD" means TOWARDS THE TRACTOR.
5. Reference to "REAR" means AWAY FROM THE TRACTOR.

**SAFETY-ALERT SYMBOL**



This symbol is an alert to the potential for personal injury. This symbol means **ATTENTION! BECOME ALERT!**  
**YOUR PERSONAL SAFETY IS INVOLVED!**

GENERAL SAFETY PRACTICES



YOU ARE RESPONSIBLE for the safe assembly of the machine.



BLOCK UP ANY RAISED PART of the machine. Be sure machine is stable after blocking.



DO NOT ALLOW CHILDREN or other unauthorized persons within the assembly area.



ALWAYS INSPECT LIFTING CHAINS AND SLINGS for damage or wear.



WEAR PERSONAL PROTECTIVE EQUIPMENT which includes a hard hat, eye protection, work gloves and steel toed boots with slip resistant soles.



BE SURE LIFTING DEVICE IS RATED TO HANDLE THE WEIGHT.\*



DO NOT MODIFY the equipment or substitute parts in any way. Unauthorized modification may impair the function and/or safety of the machine.



STOP ENGINE, place all controls in neutral, set parking brake, remove ignition key and wait for all moving parts to stop before servicing or adjusting.



USE SUITABLE LIFTING DEVICE for components which could cause personal injury.



ALWAYS make sure Land Roller is lowered into field position (cylinders retracted), it is blocked to prevent movement and that pressure is relieved from hydraulic circuits before servicing.



USE EXTREME CARE when assembling, servicing or adjusting.

## SECTION 2 - ASSEMBLY

### Main Frame Roller Installation (Instructions for 34', 41', 46' & 53')

(NOTE: 41' shown in drawings)

MF1. Attach 8P7125 to main frame 8P7128 using supplied hardware.

MF2. Position 8P4211 on a flat even surface; block the roller to avoid unexpected movement. **CAUTION:** The 11' roller weighs 3300 lbs., use extreme care when moving rollers and frame components. **NOTE:** An H has been stamped onto one end of each roller. Position the center roller with the H to the left. All other rollers should have the H positioned to the center of the machine.

MF3. Use a fork lift or crane to position the main frame 8P7128 over the center drum and lower the frame so the roller axle stubs fit between the bearing hangers as shown in the Figure 1.

MF4. Install bearings with the **grease zerk toward the rear of the machine.** Secure to bolt plates with the hardware shown. Install reinforcement angles between the bottom attachment hole on the inside of the bolt plate, as shown in Figure 1.

MF5. Install snap rings on each roller shaft. Ensure that the roller is centered in the bearings and

**Figure 1**

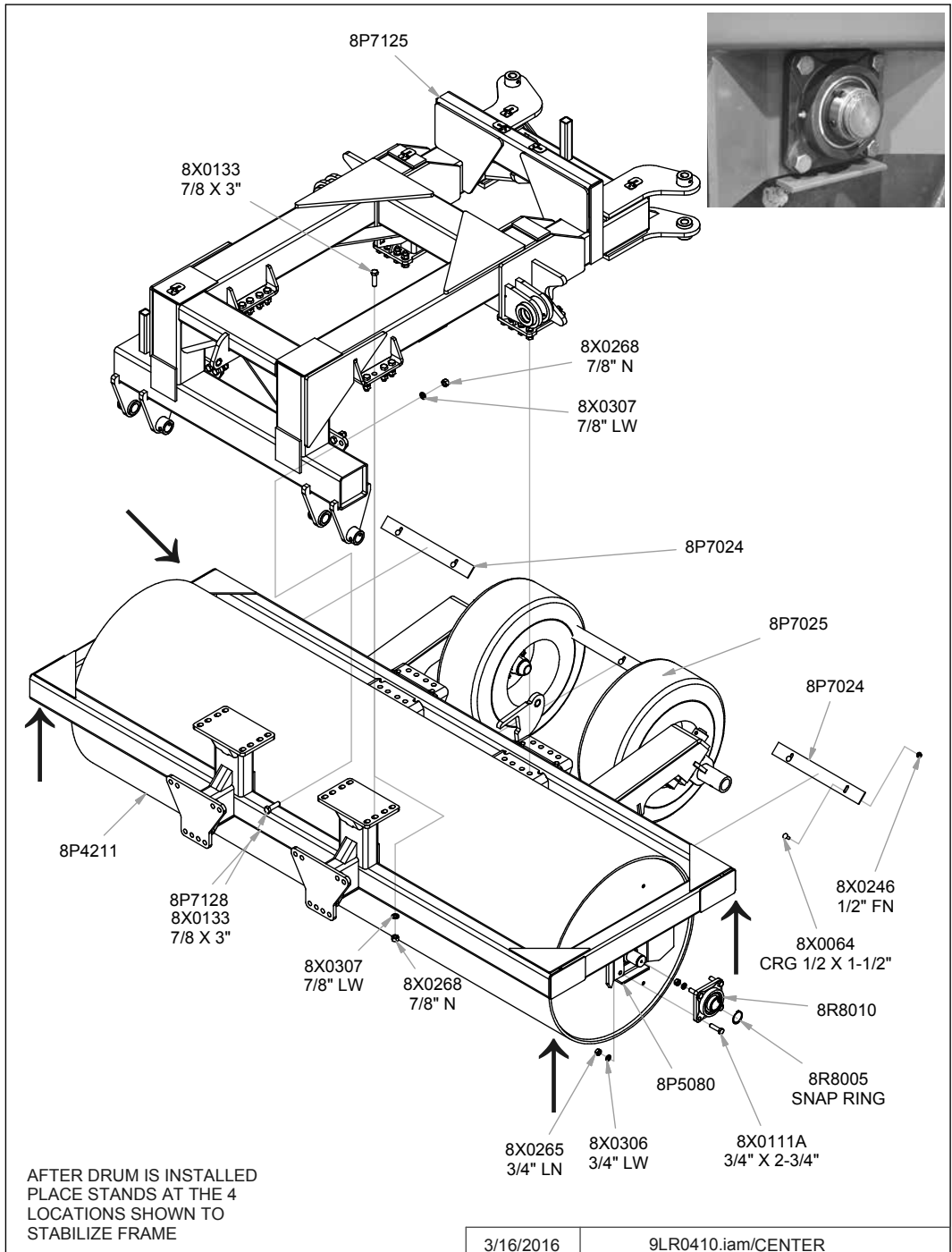

## SECTION 2 - ASSEMBLY

---

tighten the set screws.

MF6. Before removing the lifting device for the main frame, block the frame in the locations shown in Figure 1, also install blocks under the roller to keep it from rolling.

### **Hitch Installation**

H1. Position hitch as shown in Figure 2; install the pins and hardware shown in Figure 2.

#### ***IMPORTANT***

Always install the pins with the cross hole towards the outside. Pay attention to the orientation of the cross hole in the pin to the cross hole in the bushing on the main frame, only drive the pin in far enough to line up the holes, install the fasteners shown in Figure 2.

H2. Install the jack stand and pin.

H3. Install the hitch clevis and hardware shown on the front of the hitch.

H4. Install the Pivot lock and cylinder at the rear of the front hitch. Install the pins and washers as shown. Note the orientation of the pivot lock, do not install it backwards.

## SECTION 2 - ASSEMBLY

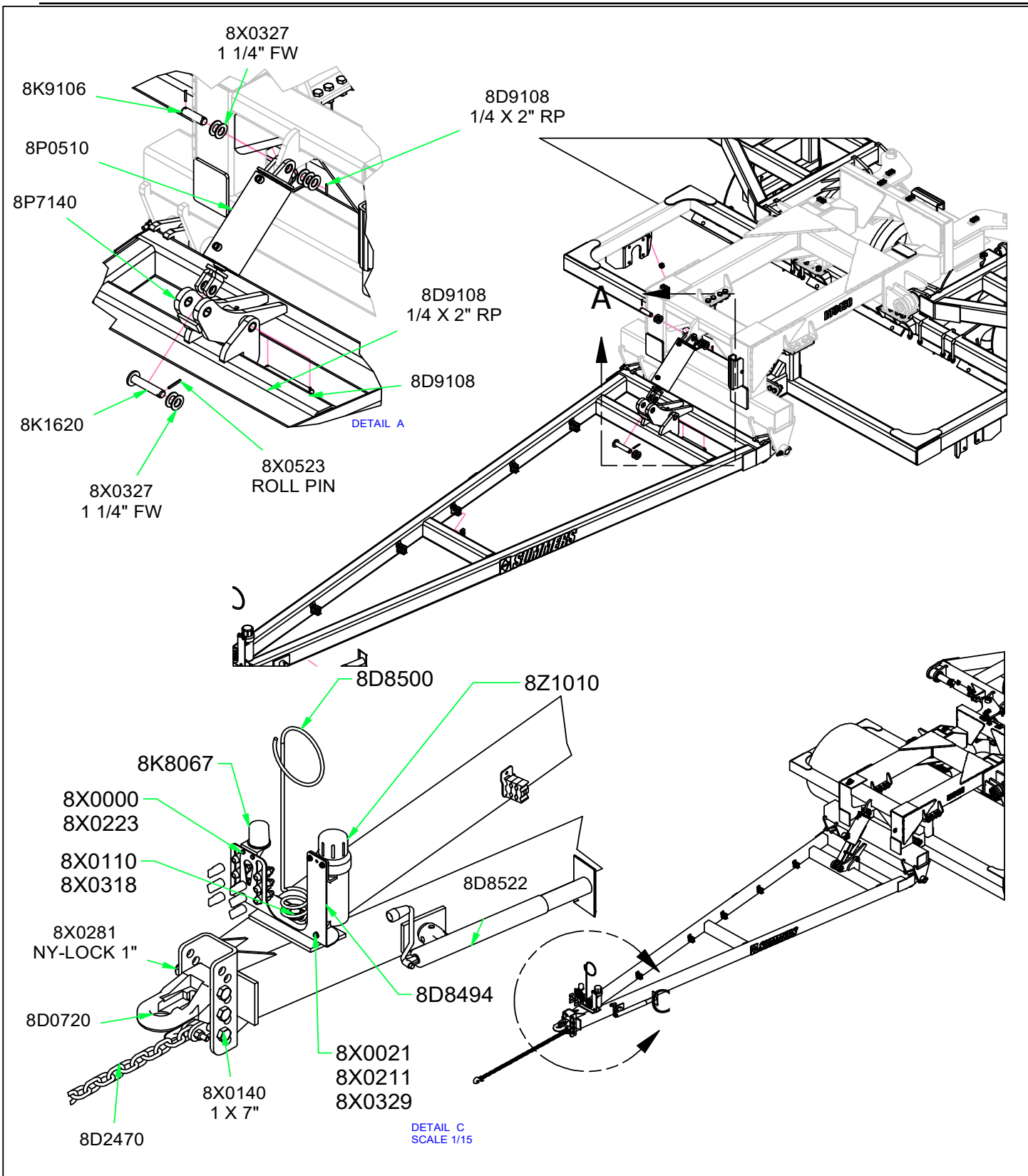

REVISION	BY	DATE
ADDED 8D8494 & 8Z1010 FOR 8D8490 & 8Z1000 RESPECTIVELY	CCV	4/17/2023

**NOTE:**  
DRUM OMITTED FROM THIS VIEW

3/16/2016	9LR0410.iam/HITCH
-----------	-------------------



## Main Frame Transport Frame Installation

- T1. Loosely position 8T4100 on the main frame and affix the hardware associated with 8T4100. Mount 8P7022 scrapers to bottom of 8T4100 as shown on page 2-7. Do not tighten the fasteners. 8T4100 should always be positioned as shown, with the offset gap to the inside.

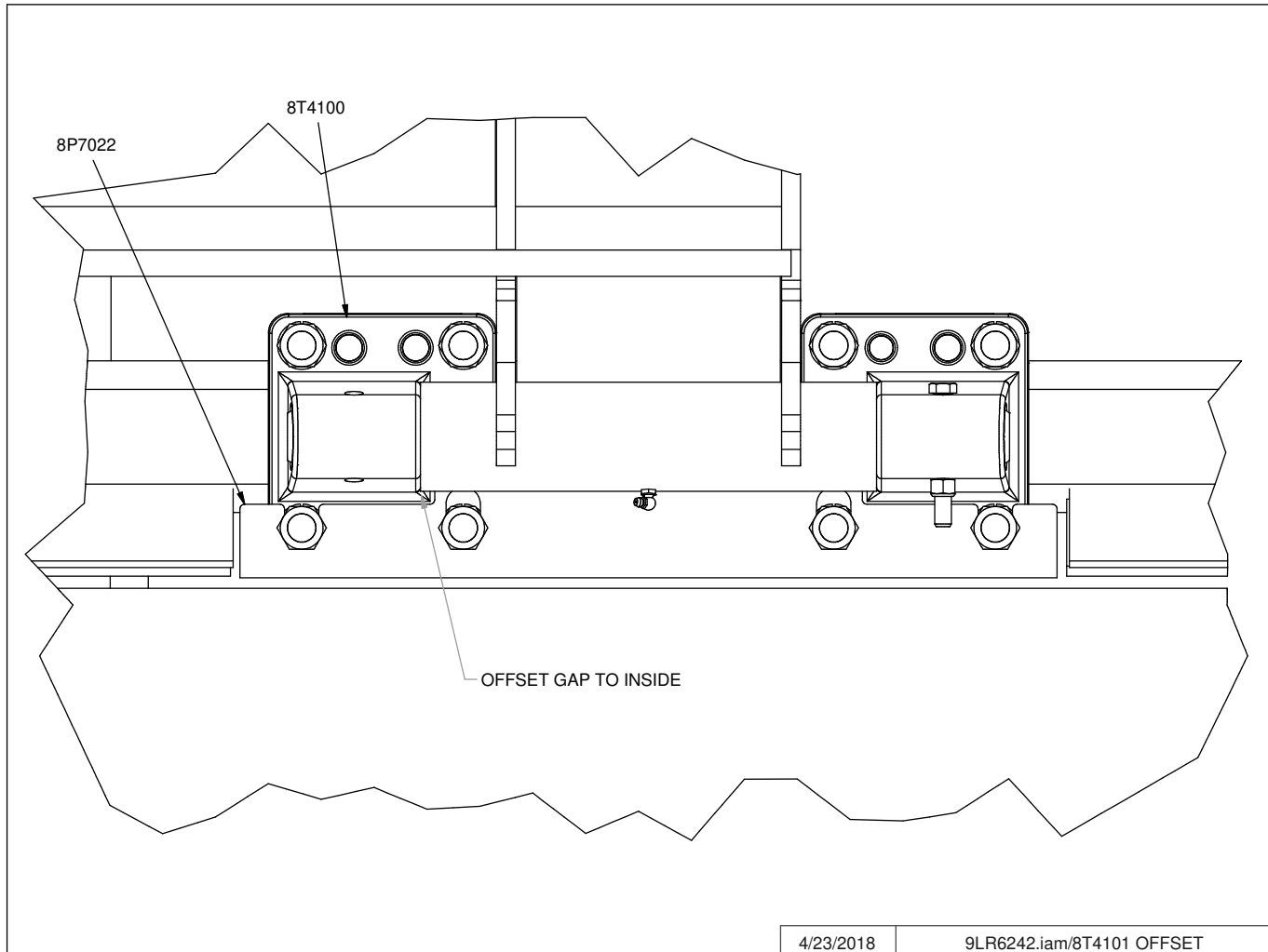

- T2. Position the transport frame at the rear of the main frame, note the orientation of the cylinders clevis. Raise the transport frame so that pin 8T3640 can be driven into 8T4100. Note the orientation of the pin, the cross hole should be towards the outside of the machine. Secure the pin with hardware shown. Make sure the transport frame is centered and tighten all hardware from step T1.
- T3. Attach the hydraulic cylinder to the main frame, with the hardware shown in the diagram. Note the number of washers on each side of the pin and the orientation of the cylinder ports.
- T4. **41'-53'**: Attach 8B1270 oscillating spindle holder to transport frame with 8B3912 pin and hardware shown.
- T5. Insert the spindles into the spindle receiver on the transport frame. Secure with the hardware shown.
- T6. Install the tires, torque the wheel nuts 240 ft-lbs.

**SECTION 2 - ASSEMBLY**

**Figure 3**

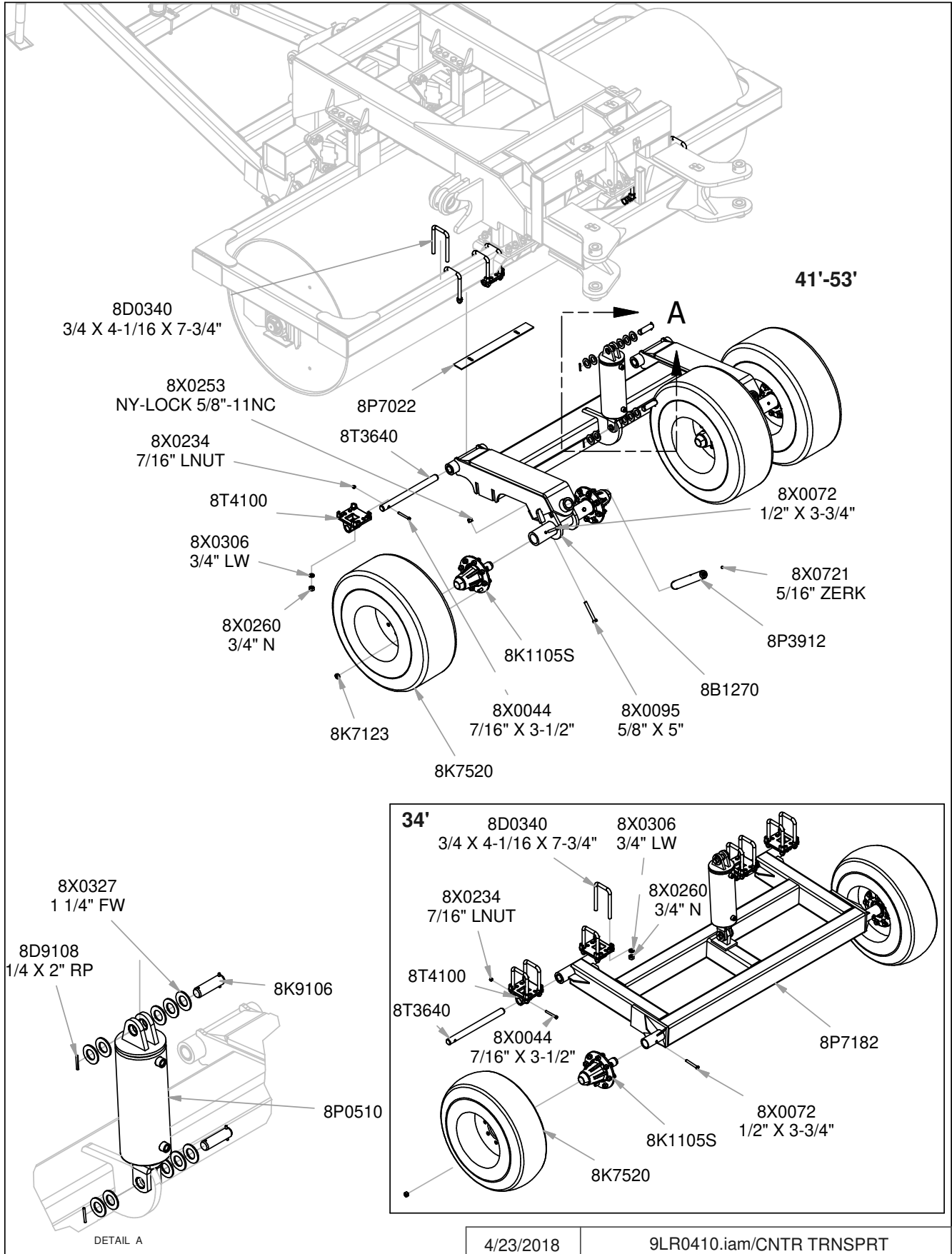

## SECTION 2 - ASSEMBLY

### Wing Installation

The following instructions depict the right wing being installed on the machine. The left hand wing will follow the same procedure.

P1W 1. Install the cast knuckle, 8C1805. The orientation of the knuckle is extremely important. Installing the knuckle in the wrong orientation will not allow the wings to fold properly. Structural damage may occur if the knuckle is installed incorrectly and the machine is unfolded. Install the pins and hardware as shown.

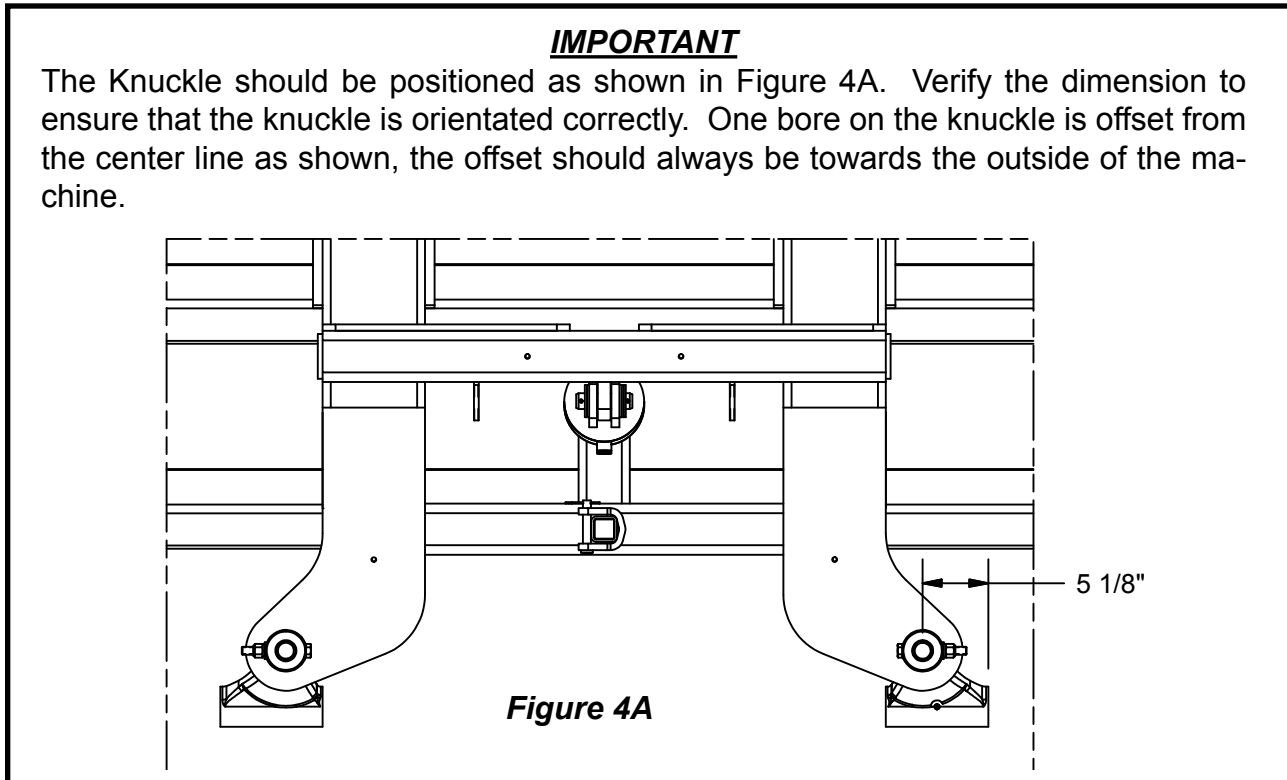

P1W 2. Position the right hand wing as shown over the knuckle. Install pin and hardware shown in Figure 4.

P1W 3. Install the small cylinder pin and pin as shown in Detail A of Figure 4. Install the roller pins. Note the orientation of the ports on the cylinder.

P1W 4. Raise the rear of the part 1 wing in the air high enough to allow the roller to be placed under the frame. **NOTE:** An H has been stamped onto one end of each roller. Position the center roller with the H to the left. All other rollers should have the H positioned to the center of the machine.

P1W5 . Install bearings with the grease zerk toward the rear of the machine (in field position). Secure to bolt plates with the hardware shown in Detail A of Figure 4. Install reinforcement angles between the bottom attachment hole on the inside of the bolt plate, as shown in Figure 4. Install snap rings on each roller shaft. Ensure that the roller is centered in the bearings and tighten the set screws.

SECTION 2 - ASSEMBLY

Figure 4

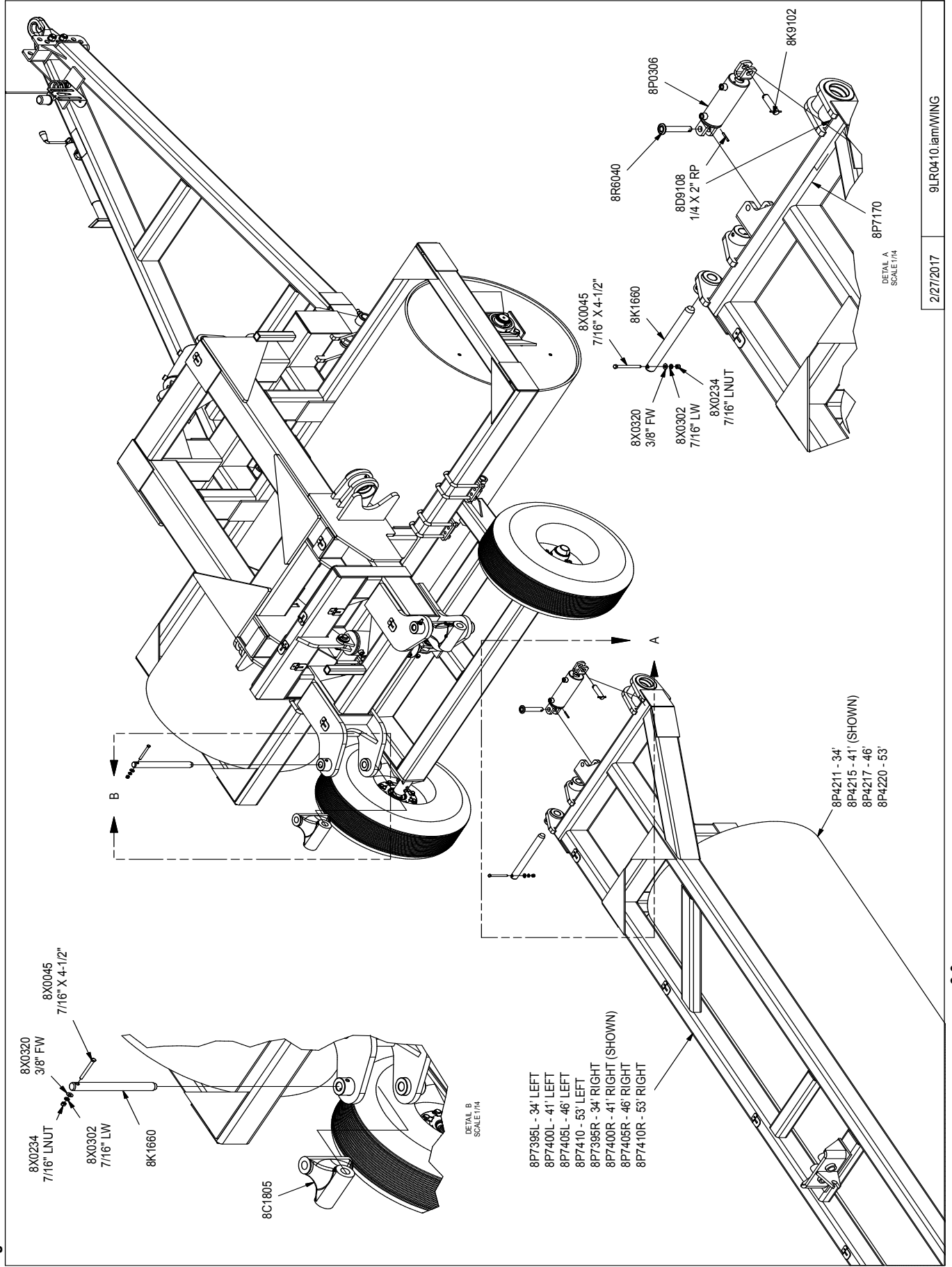

SECTION 2 - ASSEMBLY

Figure 5

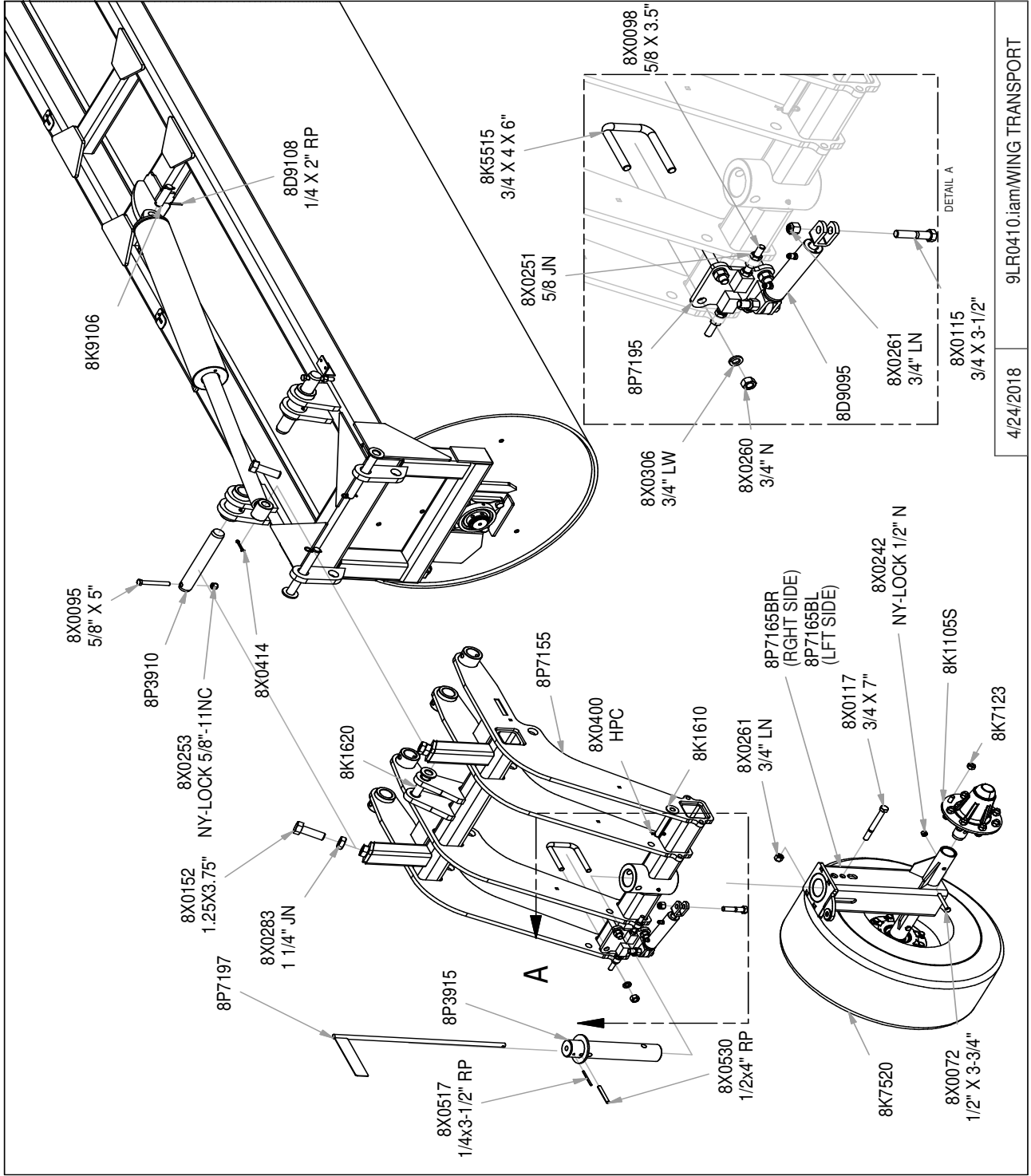

P1W6. Install the hubs on 8P7165 as shown in Figure 5. Attach with the shown hardware and tighten.

P1W7. Install the tires to the hubs installed in the previous step. Tighten the wheel nuts to 240 ft-lbs. torque.

**Scraper Installation**

S1. Install scrapers as shown in drawing on page 2-11. Use the hardware shown in detail A.

S2. Adjust scraper so they do not touch the roller.

SECTION 2 - ASSEMBLY

Figure 6

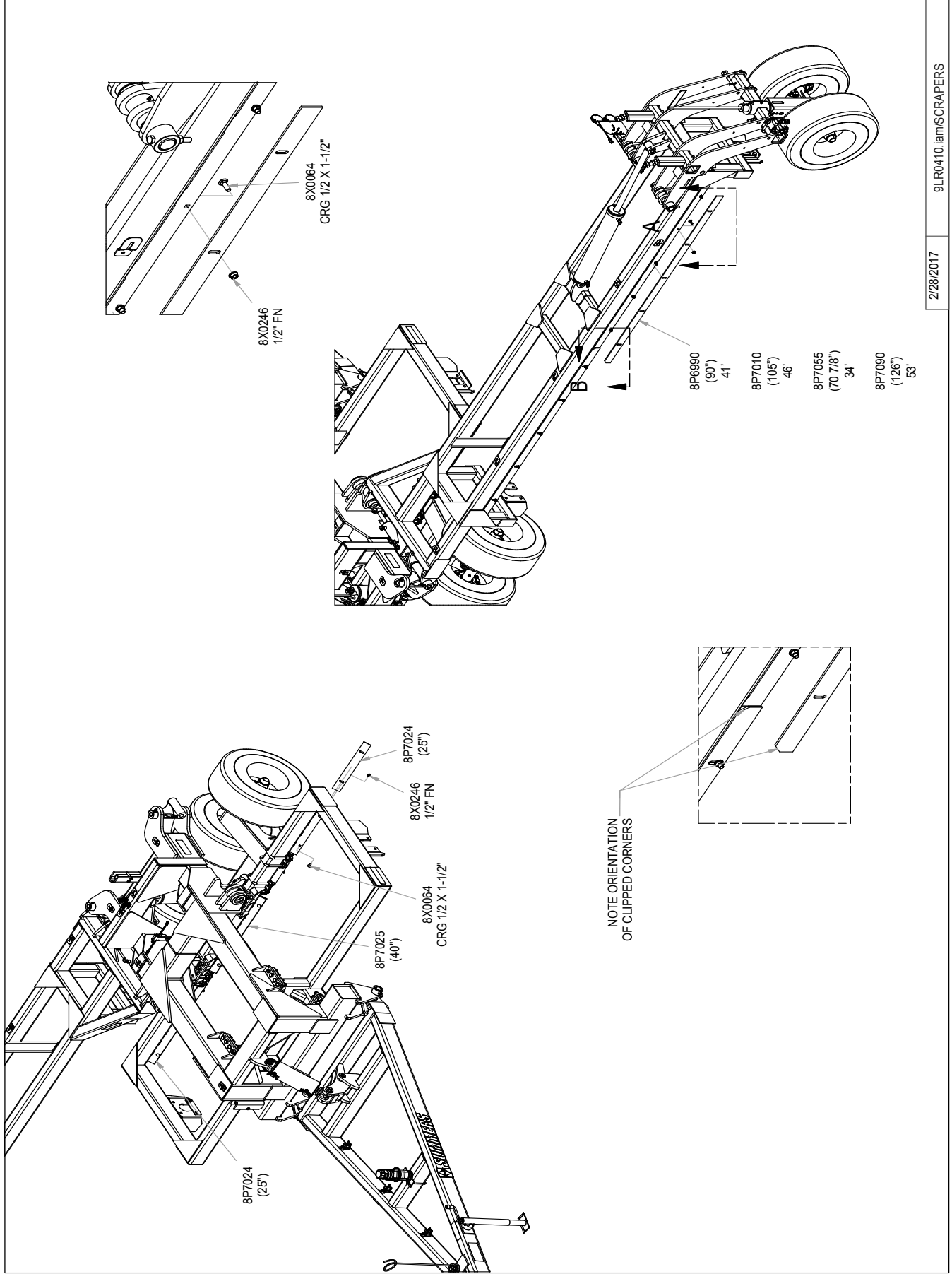

2/28/2017

9LR0410.lamSCRAPERS

SECTION 2 - ASSEMBLY

NOTE:  
MAIN LIFT CIRCUIT (RED) PLUMBED  
SO THAT ALL BASE ENDS OF CYLINDERS  
CONNECTED. ALL ROD ENDS OF  
CYLINDERS CONNECTED.

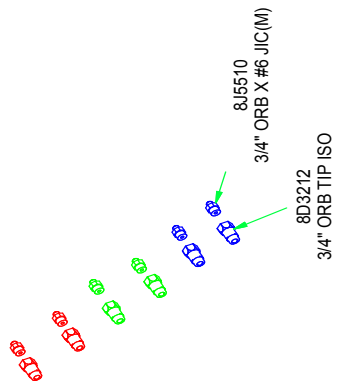
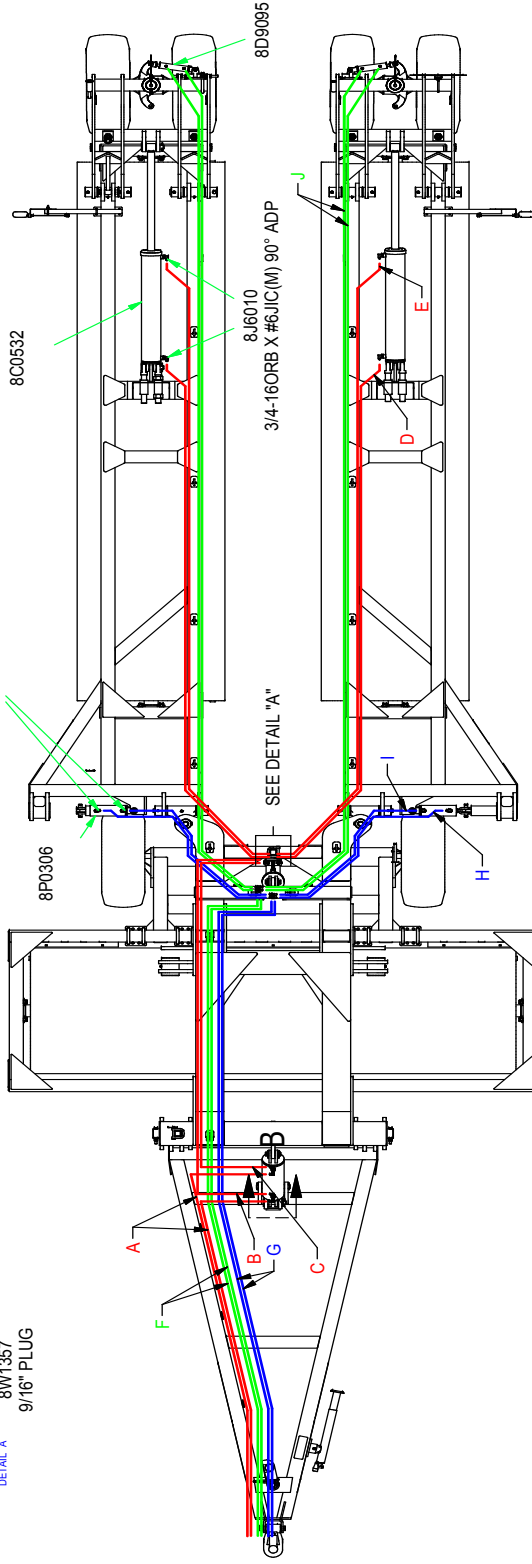
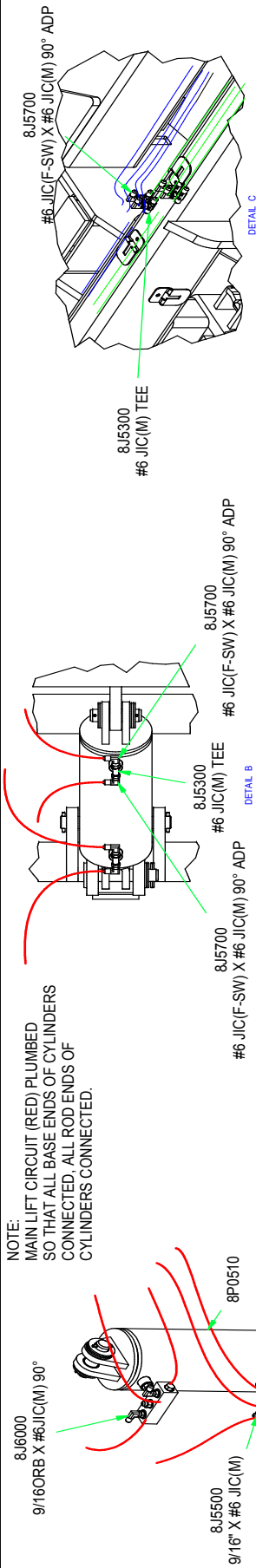

Route hoses as shown

HOSE	34"	41"	46"	53"
A	8N3228	8N3228	8N3228	8N3228
B	8N3156	8N3156	8N3156	8N3156
C	8N3150	8N3150	8N3150	8N3150
D	8N3180	8N3216	8N3252	8N3312
E	8N3204	8N3228	8N3276	8N3330
F	8N3348	8N3348	8N3348	8N3348
G	8N3348	8N3348	8N3348	8N3348
H	8N2088	8N2088	8N2088	8N2088
I	8N2076	8N2076	8N2076	8N2076
J	8N3312	8N3360	8N3390	8N3432

2/28/2017

9LR0410:iam/HYDRAULICS

## **SECTION 2 - ASSEMBLY**

---

### **Hydraulic Installation**

- H1. Install Hydraulic components as shown on Page 2-12.
  - A. Leave enough slack at all pivot points to allow folding machine without stretching or pinching hydraulic hoses.
  - B. Secure hoses with nylon ties and clamps provided. Do not over tighten clamps.
- H2. Make sure all hoses are routed the same on each side of the machine.
- H3. Secure hose with the provided clamps and hardware, use nylon ties where needed.

### **Wiring Installation**

- W1. Install lights as shown in Figure 8.
- W2. Secure wires with nylon ties.
- W3. Install rear lights as shown. Secure with hardware provided.



SECTION 2 - ASSEMBLY

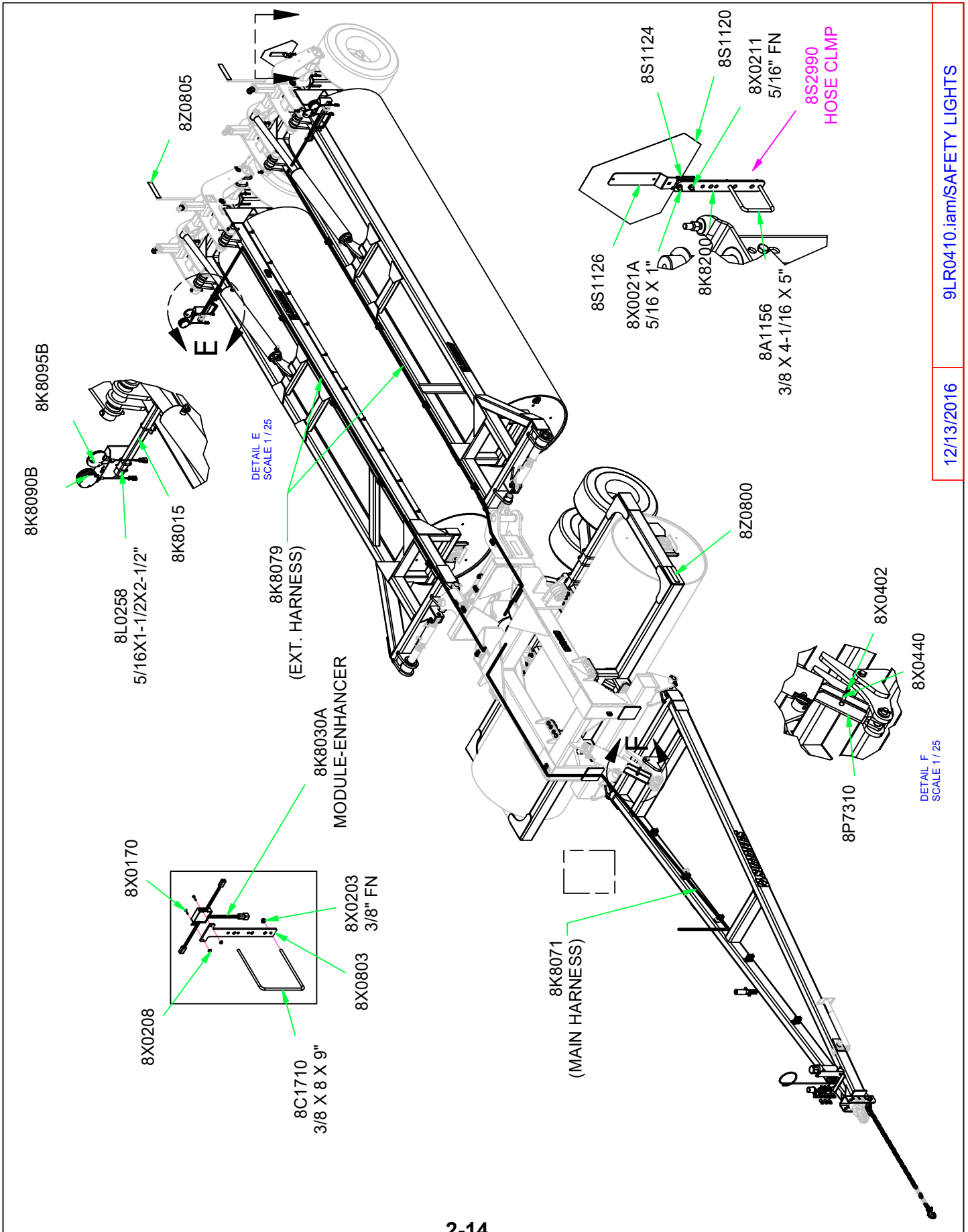

9LR0410.iam/SAFETY LIGHTS

12/13/2016

## **SECTION 3 – OPERATION**

---

### **LAND ROLLER OPERATION SAFETY**

1. READ AND UNDERSTAND Operator's Manual before using machine. Review at least annually thereafter.
2. VERIFY all safety devices and shields are in place before using machine.
3. KEEP hands, feet, hair and clothing away from moving parts.
4. STOP engine, place all controls in neutral, set parking brake, remove ignition key and wait for all moving parts to stop before servicing, adjusting, maintaining or unplugging.
5. BE CAREFUL when working around high pressure hydraulic system.
6. ALWAYS make sure Land Roller is lowered into field position (cylinders retracted), it is blocked to prevent movement and that pressure is relieved from hydraulic circuits before servicing.
7. DO NOT ALLOW RIDERS.
8. USE EXTREME CARE when making adjustments.
9. KEEP CHILDREN AWAY from machinery at all times.
10. NEVER ALLOW anyone to work under Land Roller.
11. WARNING – DO NOT ATTEMPT to raise machine into transport position if mud has built up on rollers or if machine weight has been increased by any other means. Mechanical failure may occur.

### **STEPS PRIOR TO OPERATION:**

1. COMPLETE WARRANTY REGISTRATION CARD.
  - A. Complete and return WARRANTY REGISTRATION CARD located at the beginning of this manual. Returning this card entitles you to a free gift.
  - B. Complete the OWNER REGISTER also located at the beginning of this manual (Serial Number is located by the front of the hitch). Owner register information may be needed when ordering parts.
2. VERIFY TRACTOR REQUIREMENTS.
  - A. WARNING: Land Roller must be attached directly to tractor drawbar and not an intermediate towed vehicle or implement. Loss of control could result causing serious injury or death to you or others.
  - B. Ability to safely operate the Summers Land Roller is determined by both tractor horsepower and weight. The minimum tractor weight for operating this implement is 20,000 lbs. Minimum tractor engine horsepower is 180. Dual tires or single tires set at maximum width are required for safe operation of the Land Roller.
  - C. The Summers Land Roller must be connected to a tractor drawbar with a locked draw pin. The tractor drawbar must be able to withstand 1150 lb. of tongue weight during transport and field operation.

## SECTION 3 – OPERATION

### INITIAL HOOKUP:

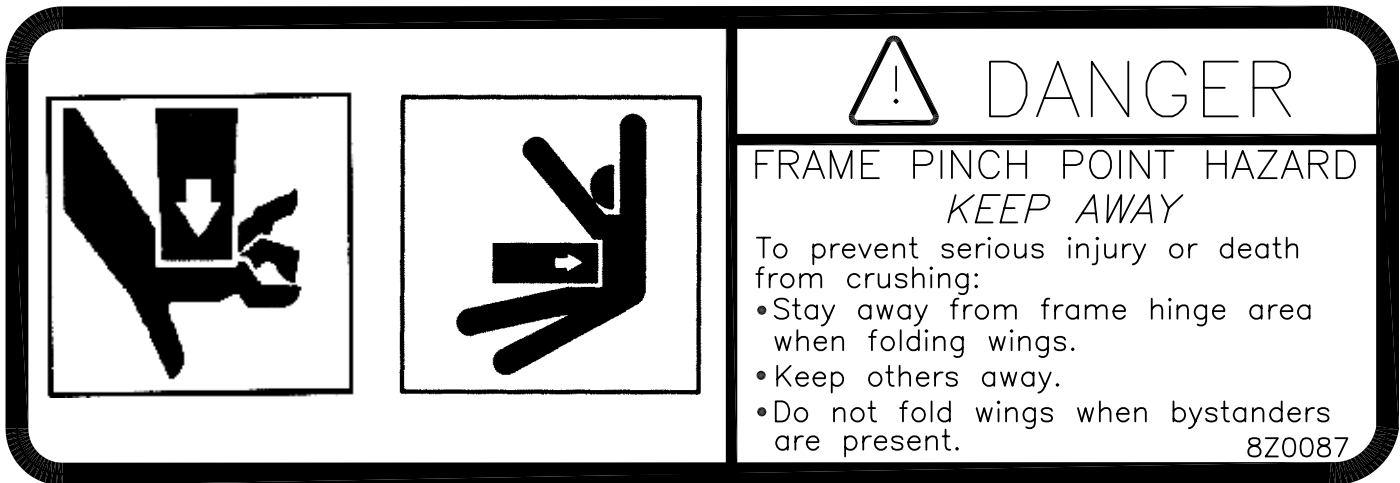

1. Make tractor to hitch connection with locking draw pin and safety chain.
2. Retract jack and rotate into storage position.
3. Plug Lockpin Cylinder hoses into desired tractor outlet, adjust hydraulic flow rate to 35% of maximum. Insure that tips and couplers are CLEAN.
4. Plug Lift Cylinder hoses into desired tractor outlet, adjust hydraulic flow rate to 35% of maximum.
5. Plug Pivot Lock Cylinder hoses into desired tractor outlet, adjust hydraulic flow rate to 35% of maximum.
6. Connect safety Light Kit wiring harness to 7 pin receptacle.
7. If Land Roller is in Transport Position, follow "Steps Required to Unfold from Transport to Field Position".
8. INITIAL CHECK – with machine in Field Position
  - A. After receiving or assembling your Land Roller, it is a good practice to double check the entire machine so all fasteners are securely tightened.
  - B. Make sure all grease fittings are in place and greased properly.
  - C. Inflate tires to recommended inflation pressure (see page 4-2), check that wheel nuts are tightened to 240 ft-lb and check that wheel bearings are correctly adjusted.

## **SECTION 3 – OPERATION**

---

### **STEPS REQUIRED TO UNFOLD FROM TRANSPORT TO FIELD POSITION:**

1. **WARNING:** Land Roller must be attached directly to tractor drawbar and not an intermediate towed vehicle or implement. Loss of control could result causing serious injury or death to you or others. Never tow this implement with less than an 20,000 lb. vehicle
2. Ability to safely operate the Summers Land Roller is determined by both tractor horsepower and weight. The minimum tractor weight for operating this implement is 20,000 lb. Minimum tractor engine horsepower is 180. Dual tires or single tires set at maximum width are required for safe operation of the Land Roller.
3. The Summers Land Roller must be connected to a tractor drawbar with a locked draw pin. The tractor drawbar must be able to withstand 3000 lb of tongue weight during transport and field operation.
4. Park tractor and Land Roller on a firm level surface with enough open area that will allow unfolding Land Roller without contacting obstructions.
5. Remove all cylinder locks and store in the provided storage locations. Remove safety latch on rear transport frame, flip to the storage position.
6. Make sure the Landroller is following straight behind the tractor. Pull into the field straight and far enough to back up the Land Roller without hitting any obstructions.
7. Pivot the rear wheel, pay attention to the indicator.
8. Back machine up slowly, maneuvering it so wings open evenly. If wings do not open evenly pull ahead and try again.
9. Once the wings have opened up, continue backing until the wings are fully engaged in the wing guides. If the wings are not opening up equally they will not engage the wing guides at the same time. Pull ahead and make adjustments so both wings enter the wing guides at the same time.
10. Fully extend the lock pin cylinders.
11. Rotate the rear wheels to the straight position.
12. Lower the machine to the ground, continue retracting the cylinders until all cylinders are fully retracted.

## **SECTION 3 – OPERATION**

---

### **LAND ROLLER FIELD OPERATION:**

1. Choose an operating speed which achieves desired results. Operating at over 7 MPH will decrease effectiveness and increase chance of immovable rocks denting roller tube. Denting of roller tube is NOT covered by warranty.
2. Slow down for turns. Because of the weight of the roller turning at high speeds may cause the tractor to “fish tail”. Control will be more easily maintained at slow rates of turns.

### **STEPS REQUIRED TO FOLD FROM FIELD TO TRANSPORT POSITION:**

1. **WARNING:** Land Roller must be attached directly to tractor drawbar and not an intermediate towed vehicle or implement. Loss of control could result causing serious injury or death to you or others. Never tow this implement with less than an 20,000 lb vehicle.
2. The Summers Land Roller must be connected to a tractor drawbar with a locked draw pin. The tractor drawbar must be able to withstand 1150 lb of tongue weight during transport and field operation.
3. **WARNING: DO NOT ATTEMPT to raise machine into transport position if mud has built up on rollers or if machine weight has been increased by any other means.**
4. Activate the wing lock cylinders valve and fully retract the wing lock cylinders.
5. Raise the machine into transport position. Make sure all cylinders have fully extended. Make sure the rear wheels are straight, pay attention to the indicator flag.
6. Install cylinder safety locks.

## **SECTION 3 – OPERATION**

---

### **TRANSPORTING LAND ROLLER:**

1. If Land Roller is in Field Position, follow “Steps Required to Fold Land Roller from Field to Transport Position”, page 3-4.
2. Ability to safely operate the Summers Superroller is determined by both tractor horsepower and weight. The minimum tractor weight for operating this implement is 20,000 lbs. Minimum tractor engine horsepower is 180. Dual tires or single tires set at maximum width are required for safe operation of Land Roller.
3. **ONLY TOW** at a safe speed – 20 MPH MAXIMUM. Use caution when making corners or meeting traffic.
4. **USE Safety Lights and Safety Chain** between tractor drawbar and implement hitch when transporting on public roads.
5. **ALWAYS** install lift cylinder locks.
6. **FOLLOW ALL** local laws governing transporting of farm machinery.
7. Use additional caution and reduce speed when towing under adverse conditions, when turning and when on unlevel surfaces.
8. Stay clear of overhead lines and other overhead obstructions.
9. Frequently check for traffic from rear, especially during turns.

### **UNHOOKING LAND ROLLER FROM TRACTOR IN FIELD POSITION:**

1. **NEVER** unhook Land Roller if positioned between Field and Transport Position.
2. Choose a firm level surface.
3. With Land Roller in Field Position; shut off tractor, engage parking brake and relieve hydraulic pressure by cycling remote lever.
4. Block rollers to prevent movement after hitch pin is removed.
5. Check that hitch pin is not bound with sideways or front to back pressure. If hitch pin is not free, carefully reposition tractor.
6. Rotate jack into vertical position and extend jack until hitch piece lifts off tractor drawbar.
7. Disconnect wiring harness, hydraulic hoses and safety chain.
8. Recheck that hitch pin is free, if so, stand to the side of the hitch and remove hitch pin.
9. Carefully drive ahead.

## SECTION 3 – OPERATION

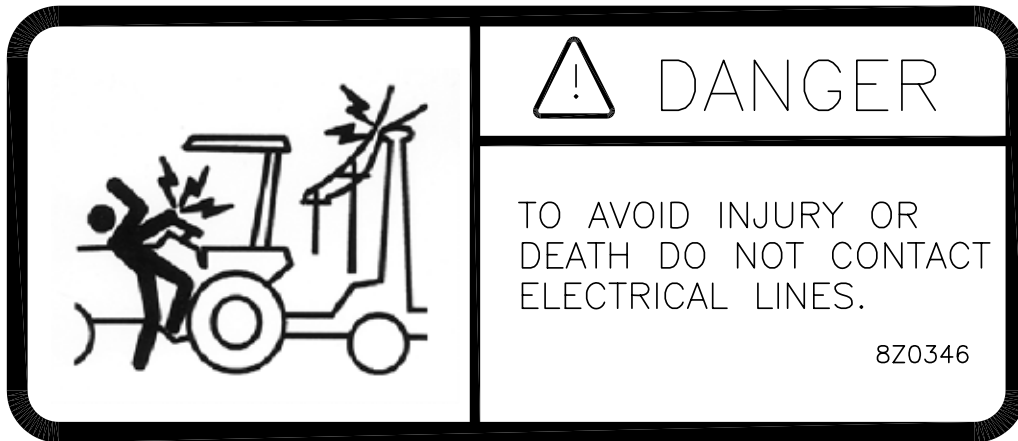

### **UNHOOKING LAND ROLLER FROM TRACTOR IN TRANSPORT POSITION:**

1. **NEVER** unhook Land Roller if positioned **between** Field and Transport Position.
2. DO NOT ALLOW ANYONE TO WORK UNDER LAND ROLLER.
3. Choose a very firm level surface.
4. Block tires to prevent movement after hitch pin is removed.
5. Check that hitch pin is not bound with sideways or front to back pressure. If hitch pin is not free, carefully reposition tractor
6. Rotate jack into vertical position, place sturdy block under jack to distribute load over larger area and extend jack until hitch piece just lifts off tractor drawbar.
7. Disconnect wiring harness, hydraulic hoses and safety chain.
8. Recheck that hitch pin is free, if so, stand to the side of the hitch and remove hitch pin.
9. Carefully drive ahead.

## SECTION 4 – MAINTENANCE

### MAINTENANCE SAFETY

1. STOP engine, place all controls in neutral, set parking brake, remove ignition key and wait for all moving parts to stop before servicing, adjusting or maintaining.
2. BE CAREFUL when working around high pressure hydraulic system.
3. ALWAYS make sure that Land Roller is lowered into field position, it is blocked to prevent movement and pressure is relieved from hydraulic circuits before servicing.
4. USE EXTREME CARE when making adjustments.
5. KEEP CHILDREN AWAY from machinery at all times.
6. NEVER ALLOW anyone to work under Land Roller.

	<p style="text-align: center;"> <b>WARNING</b></p> <p><b>HIGH-PRESSURE FLUID HAZARD</b></p> <p>To prevent serious injury or death:</p> <ul style="list-style-type: none"><li>•Relieve pressure on system before repairing or adjusting or disconnecting.</li><li>•Wear proper hand and eye protection when searching for leaks. Use wood or cardboard instead of hands.</li><li>•Keep all components in good repair.</li></ul> <p style="text-align: right;">SW700</p>
--	---

### MAINTENANCE FOR AFTER THE FIRST FOUR HOURS OF OPERATION

1. Grease wing and hitch pivots.
2. Check all hydraulic components for leaks. (SEE HIGH-PRESSURE FLUID WARNING ABOVE.)
3. Check tightness of wheel nuts. Recommended torque 240 ft. lbs.
4. Check tightness of wheel bearings.
5. Check tightness of all hardware. Pay special attention to hitch and pivot pin retaining bolts.
6. Check tire pressures. Recommended air pressure is 90 PSI for 12.5Lx15 tires; 78 PSI for 340/65Rx18 tires.

### DAILY MAINTENANCE

1. Grease wing and hitch pivots.
2. Check all hydraulic components for leaks. (SEE HIGH-PRESSURE FLUID WARNING ABOVE.)
3. Check tightness of all wheel nuts. Recommended torque 240 ft. lbs.
4. Check tire air pressure. Recommended air pressure is 90 PSI.

**BALL BEARINGS ON ROLLERS:** To maximize bearing life, grease bearings at mid day or end of day when bearings are at operating temperature. **Every 20 hours:** Add three strokes (approx. .14 oz.) of grease.



**SECTION 4 – MAINTENANCE**

**STORAGE**

1. Follow steps outlined in “UNHOOKING LAND ROLLER FROM TRACTOR IN FIELD POSITION”.
2. Clean and remove all excessive dirt and grease from Land Roller.
3. Grease all zerks.
4. To prevent rusting, repaint any areas that have been worn, chipped or scratched.
5. Apply grease\* to any exposed part of cylinder shafts.

\*NOTE: Before returning Land Roller into service, all grease must be removed from cylinder shafts to prevent damage to seals.

**SPECIFICATIONS**

Working Width	Transport Width	Transport Height	Transport Length	Machine Weight	Roller Diameter
<b>34'</b>	<b>12'6"</b>	<b>6'8"</b>	<b>38'7"</b>	<b>20,600#</b>	<b>42"</b>
<b>41'</b>	<b>12'6"</b>	<b>6'8"</b>	<b>42'5"</b>	<b>22,880#</b>	<b>42"</b>
<b>46'</b>	<b>12'6"</b>	<b>6'8"</b>	<b>45'</b>	<b>24,310#</b>	<b>42"</b>
<b>53'</b>	<b>12'6"</b>	<b>6'8"</b>	<b>52'5"</b>	<b>25,840#</b>	<b>42"</b>

Tire Size	Rating	Recommended Inflation Pressure
12.5Lx15	LRF	90 PSI
340/65R18	148A8	78 PSI

Hub Size	Rating	Recommended Wheel Nut Torque	Recommended Axle Nut Torque
HD812	6100 LB. 20 MPH Maximum	240 ft.-lbs.	45 ft.-lbs., loosen until first slot is aligned with hole in axle, install cotter pin, bend to retain.
HD817	7500 LB. 20 MPH Maximum	240 ft.-lbs.	45 ft.-lbs., loosen until first slot is aligned with hole in axle, install cotter pin, bend to retain.

OWNER REGISTER INFORMATION, LOCATED AT THE BEGINNING OF THIS MANUAL, MAY BE NEEDED WHEN ORDERING PARTS (SERIAL NUMBER IS LOCATED BY THE FRONT OF THE HITCH).

# SECTION 5 – PARTS

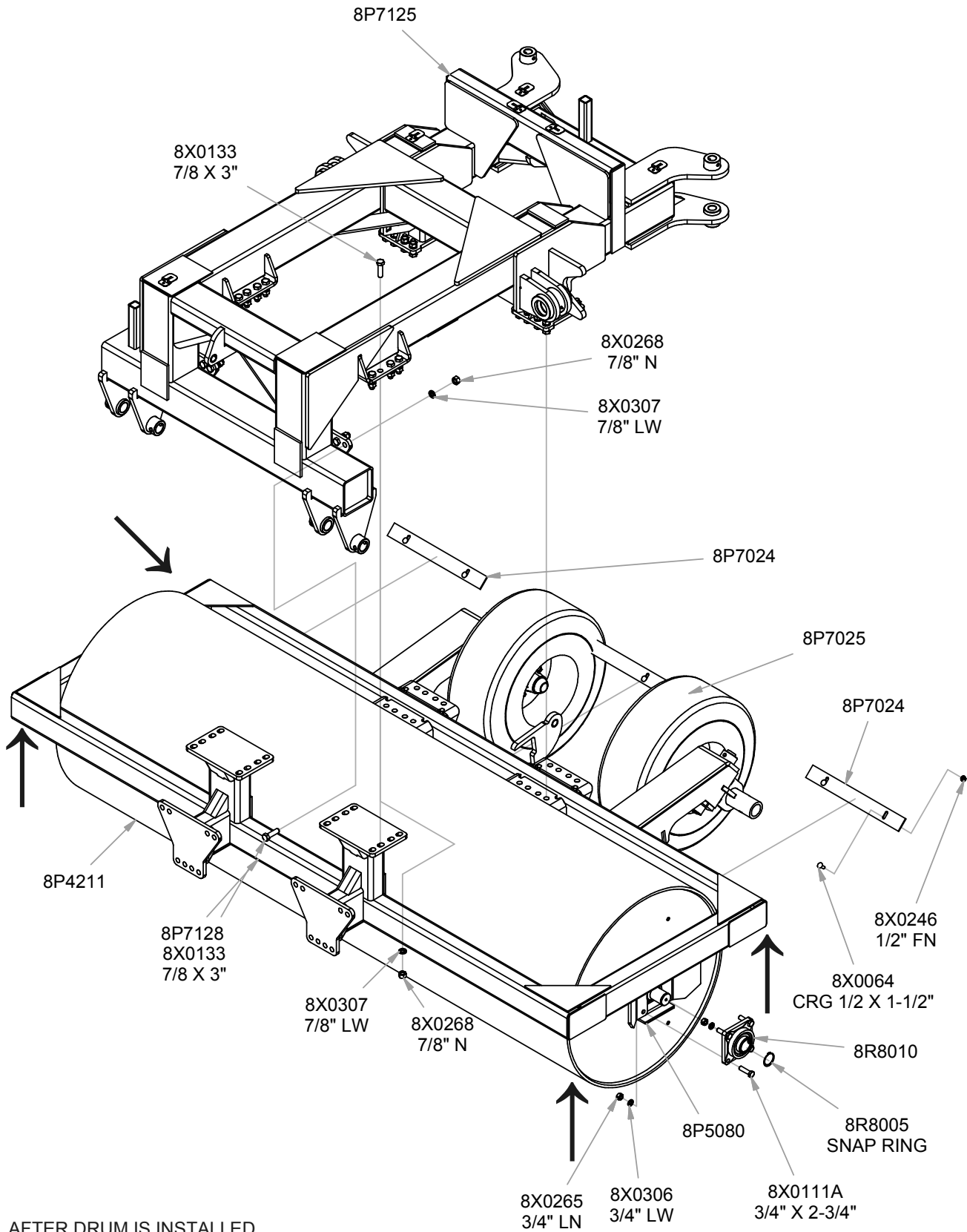

AFTER DRUM IS INSTALLED  
PLACE STANDS AT THE 4  
LOCATIONS SHOWN TO  
STABILIZE FRAME

3/16/2016

9LR0410.iam/CENTER

# SECTION 5 – PARTS

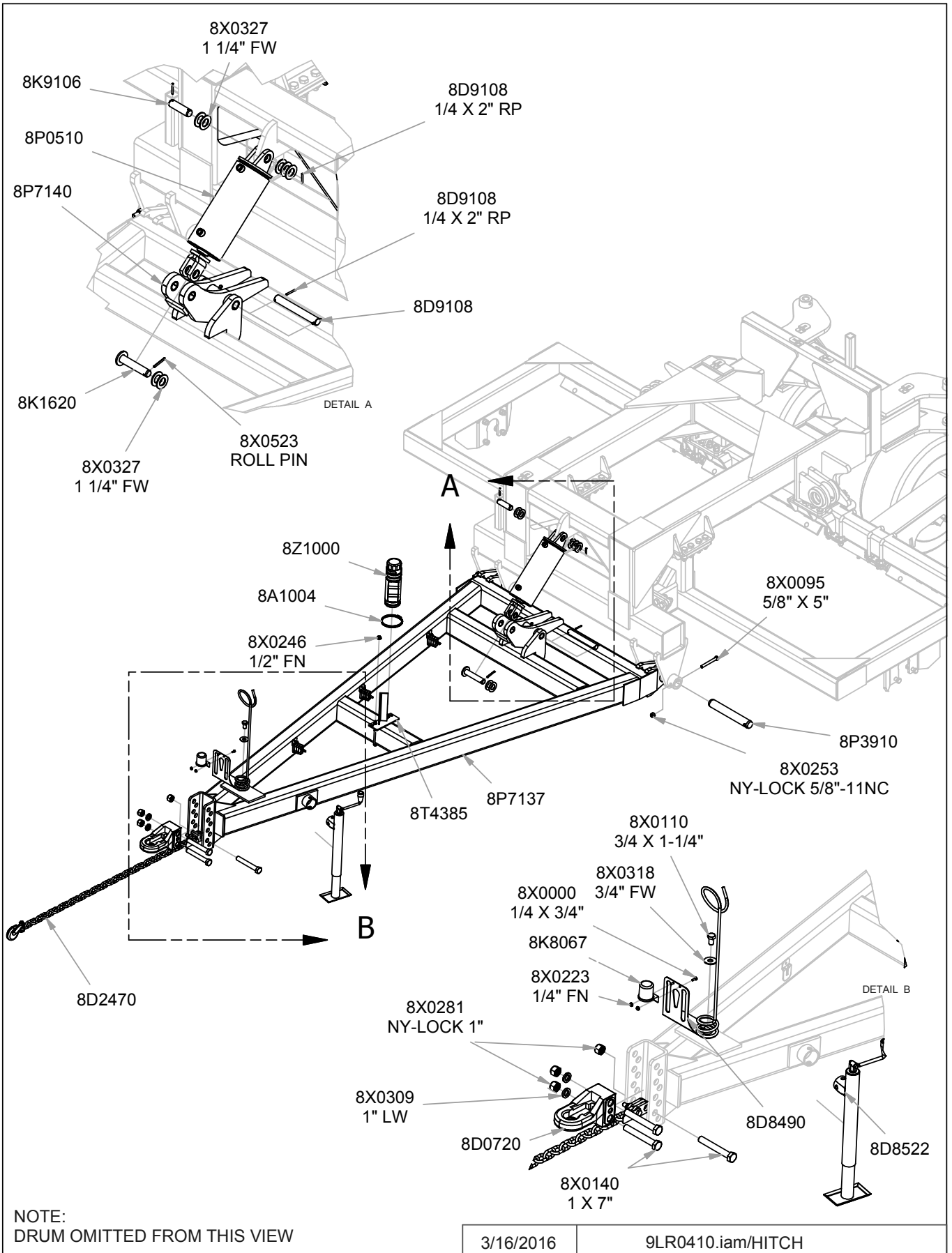

# SECTION 5 – PARTS

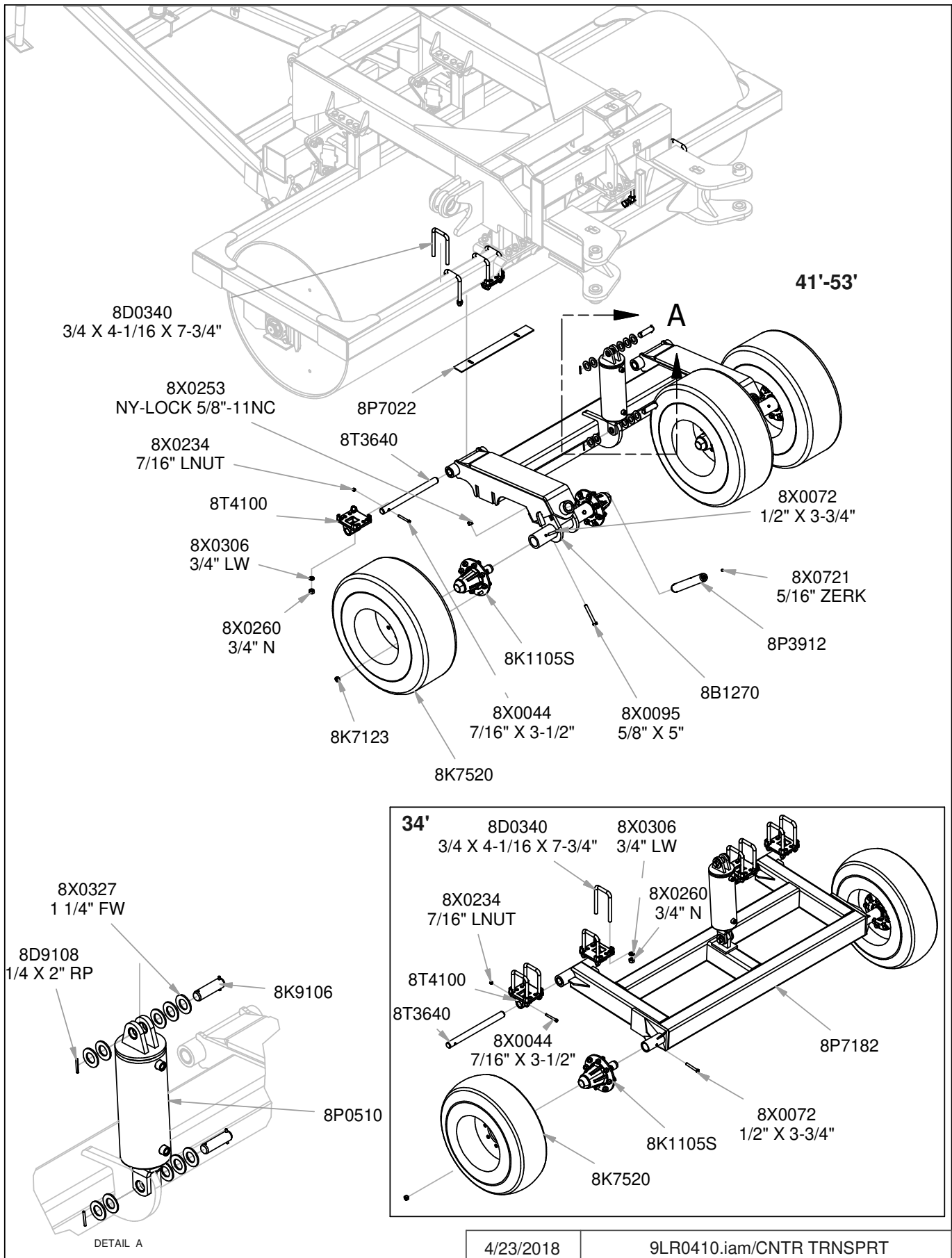

SECTION 5 - PARTS

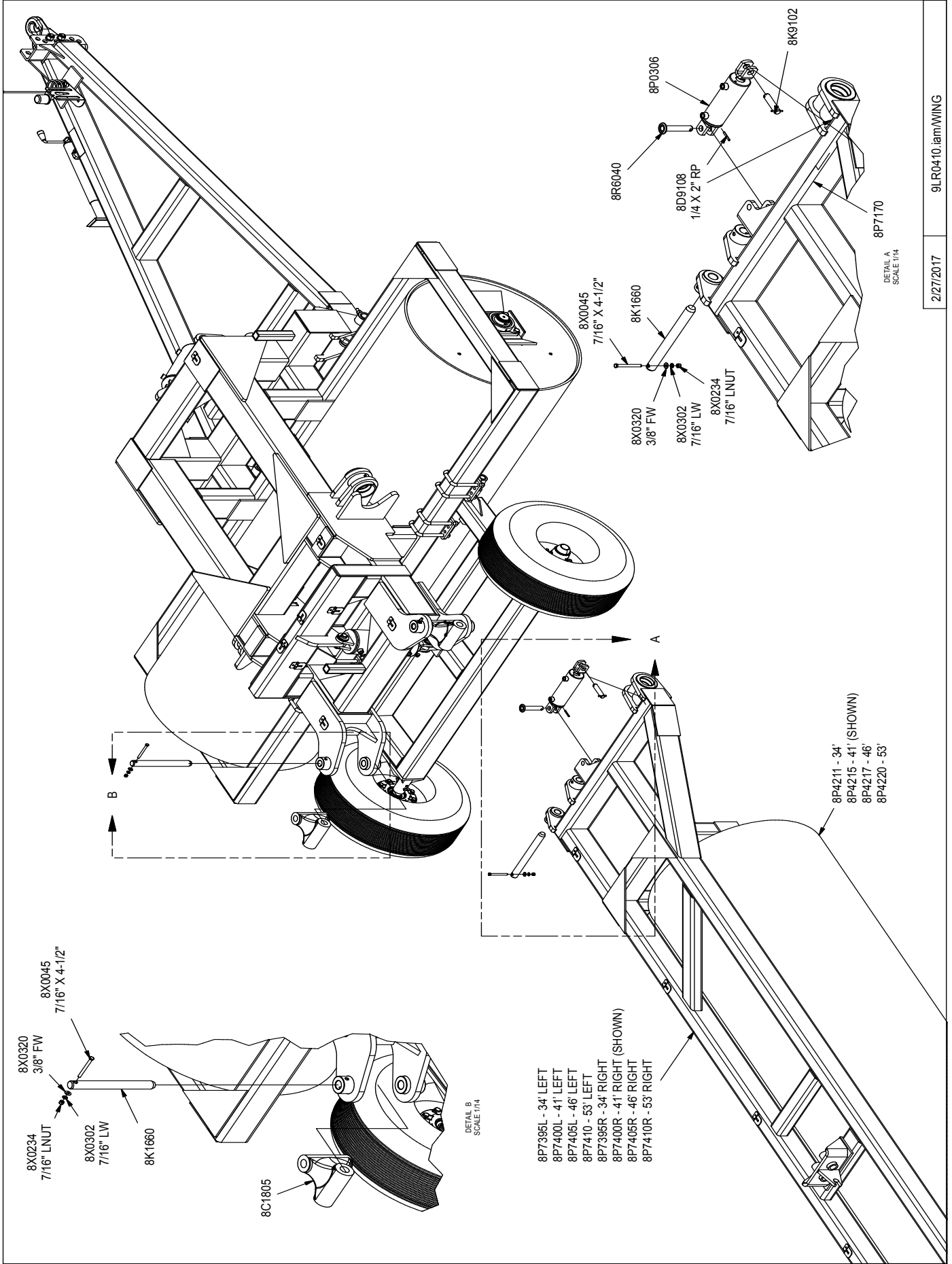

SECTION 5 - PARTS

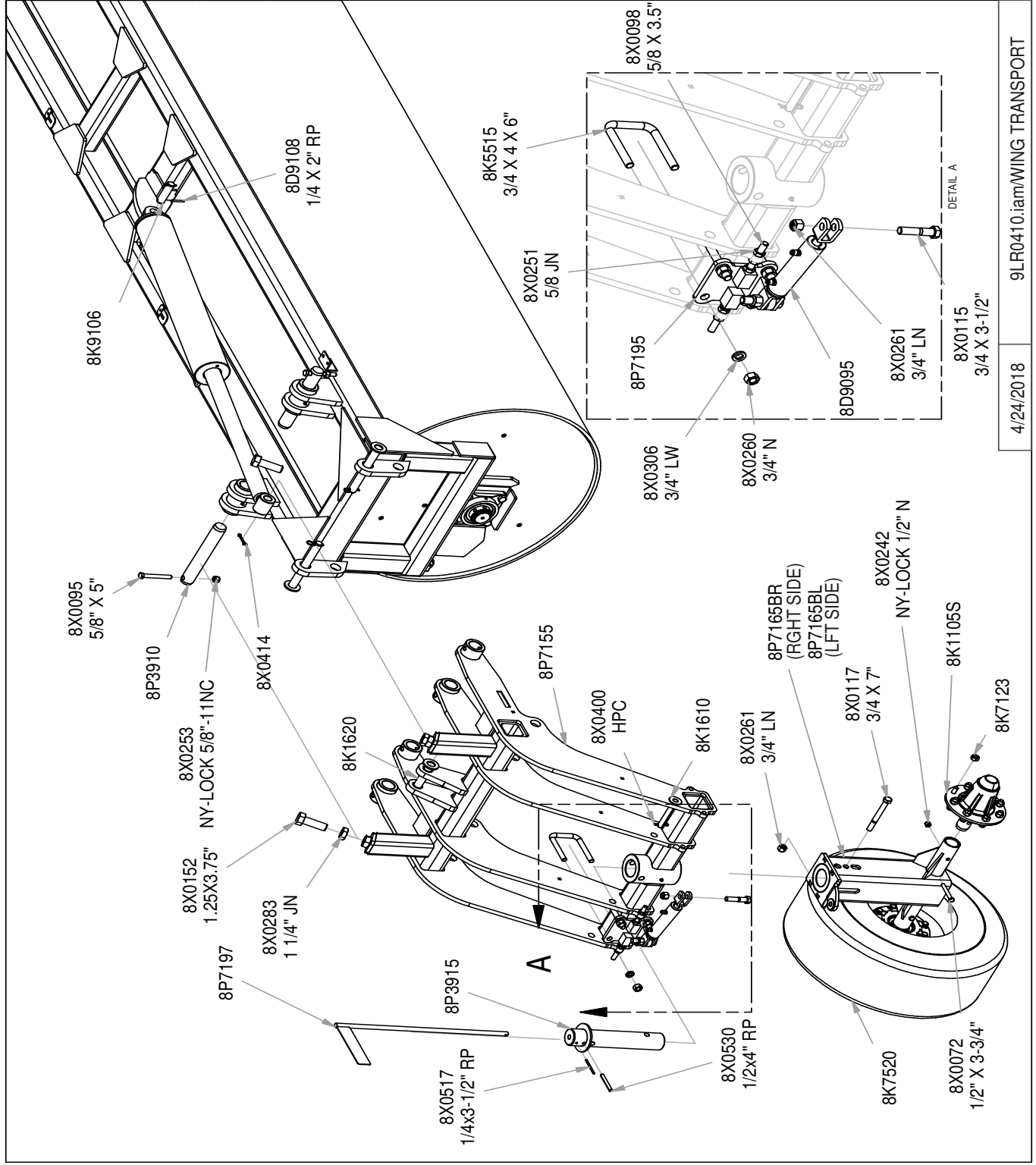

# SECTION 5 – PARTS

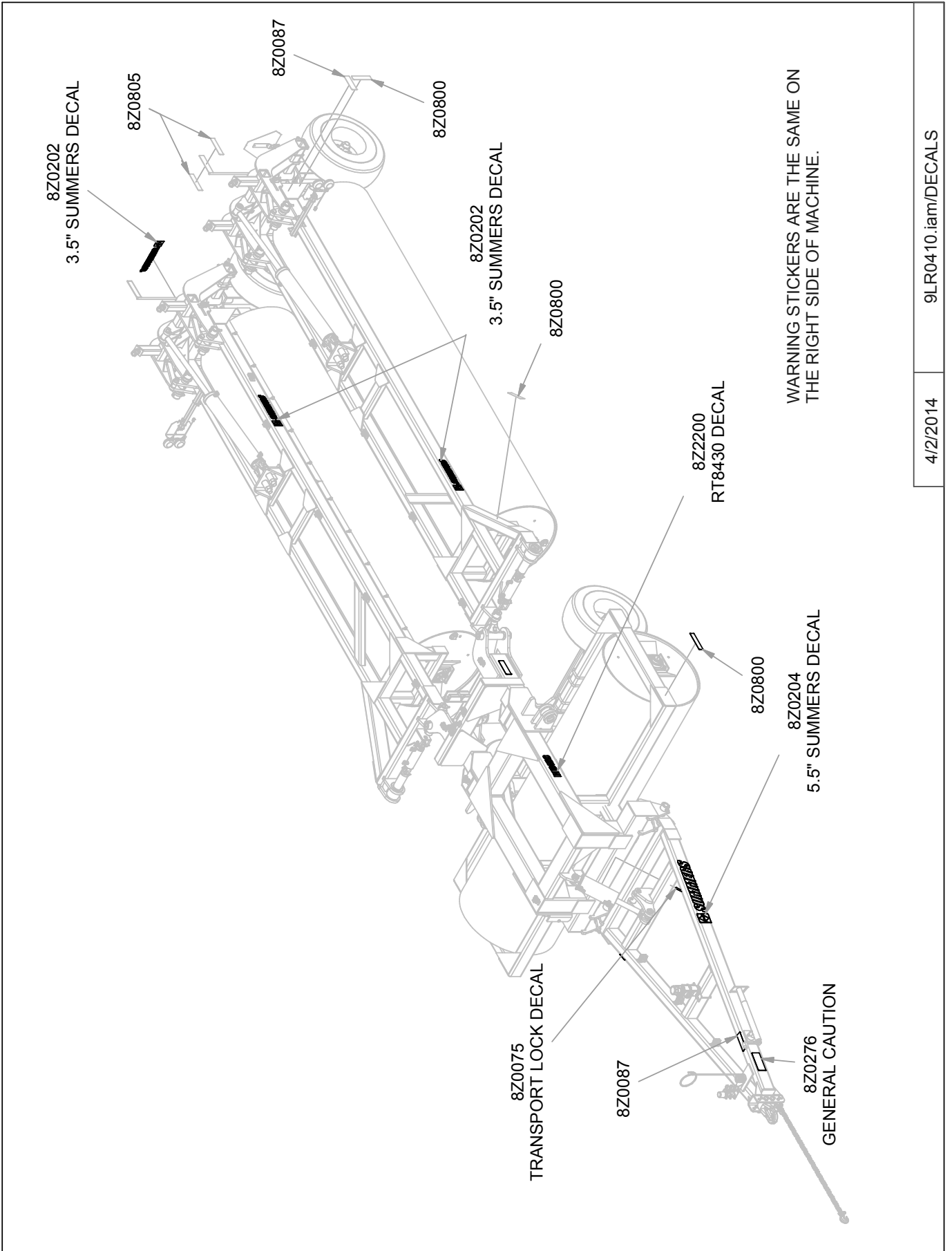

WARNING STICKERS ARE THE SAME ON THE RIGHT SIDE OF MACHINE.



## SECTION 5 – PARTS

### 3-SECTION LANDROLLER HUBS

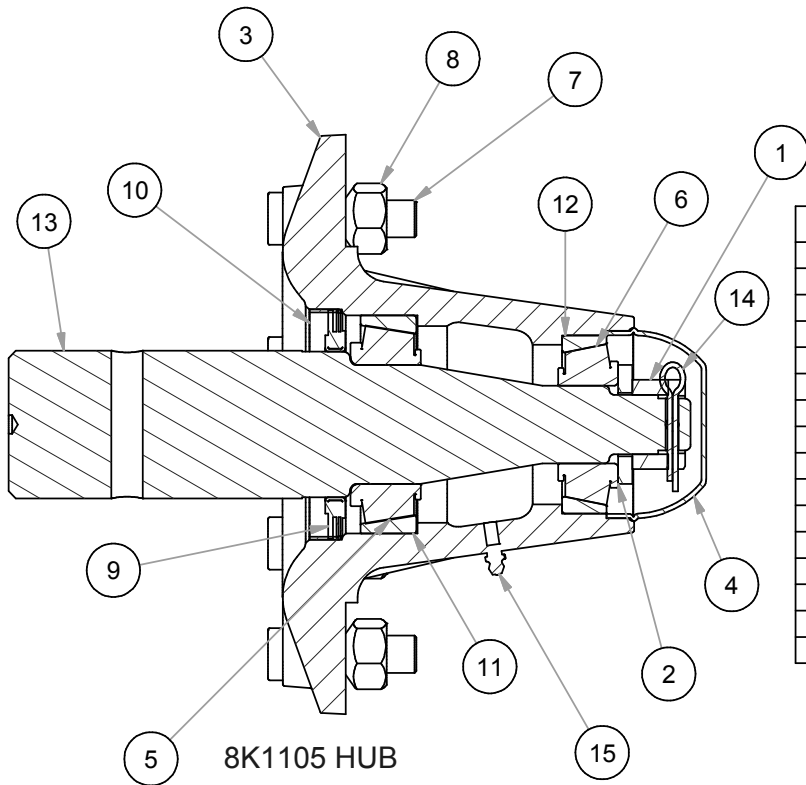

8K1105 Hub Parts List		
ITEM	PART NUMBER	DESCRIPTION
1	8D5312	NUT 1"-14NF HEX SLOT GR2 PLN
2	8D5319	WASHER 1" AXLE
3	8K7111	812 HUB ASSEMBLY
4	8K7113	HUB CAP HD812 DC17
5	8K7117	BEARING INNER HD812 LM3780
6	8K7118	BEARING OUTER HD812 LM2790
7	8K7122	STUD WHEEL 5/8-18UNFX2.5" 97-
8	8K7123	NUT WHEEL BOLT 5/8-18UNF 97-
9	8K7127	SEAL TRPL LIP EXTRNL HD812 06-
10	8K7128	SEAL SLEEVE HD812 06-
11	8K7130	RACE INNER FOR HD812 LM3720
12	8K7132	RACE OUTER FOR HD812 LM2720
13	8K7150	AXLE HD812 X 11.5" (2.5"DIA.)
14	8X0415	COTTER PIN 3/16 X 1-1/2"
15	8X0708	ZERK 1/4"-28 NF STR YZ

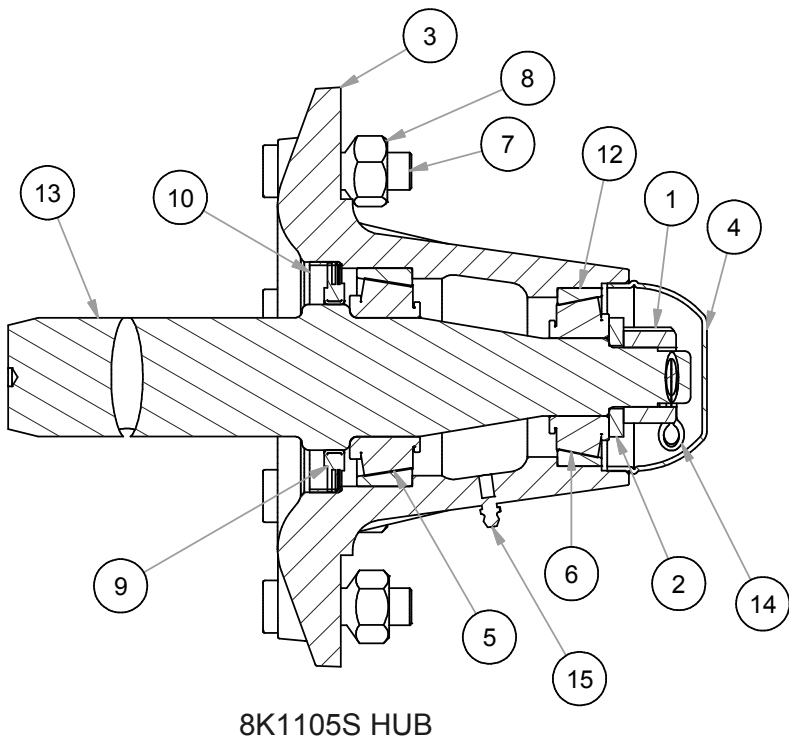

8K1105S Hub Parts List		
ITEM	PN	DESCRIPTION
1	8D5312	NUT 1"-14NF HEX SLOT GR2 PLN
2	8D5319	WASHER 1" AXLE
3	8K7111	812 HUB ASSEMBLY
4	8K7113	HUB CAP HD812 DC17
5	8K7117	BEARING INNER HD812 LM3780
6	8K7118	BEARING OUTER HD812 LM2790
7	8K7122	STUD WHEEL 5/8-18UNFX2.5" 97-
8	8K7123	NUT WHEEL BOLT 5/8-18UNF 97-
9	8K7127	SEAL TRPL LIP EXTRNL HD812 06-
10	8K7128	SEAL SLEEVE HD812 06-
11	8K7130	RACE INNER FOR HD812 LM3720
12	8K7132	RACE OUTER FOR HD812 LM2720
13	8K7150S	AXLE HD812X 11.5" (2"DIA.RCVR)
14	8X0415	COTTER PIN 3/16 X 1-1/2"
15	8X0708	ZERK 1/4"-28 NF STR YZ

2/28/2017

3-SEC\_LR-HUBS.idw/HUB/AXLE CMPNNTS

# SECTION 5 - PARTS

NOTE:  
MAIN LIFT CIRCUIT (RED) PLUMBED  
SO THAT ALL BASE ENDS OF CYLINDERS  
CONNECTED, ALL ROD ENDS OF  
CYLINDERS CONNECTED.

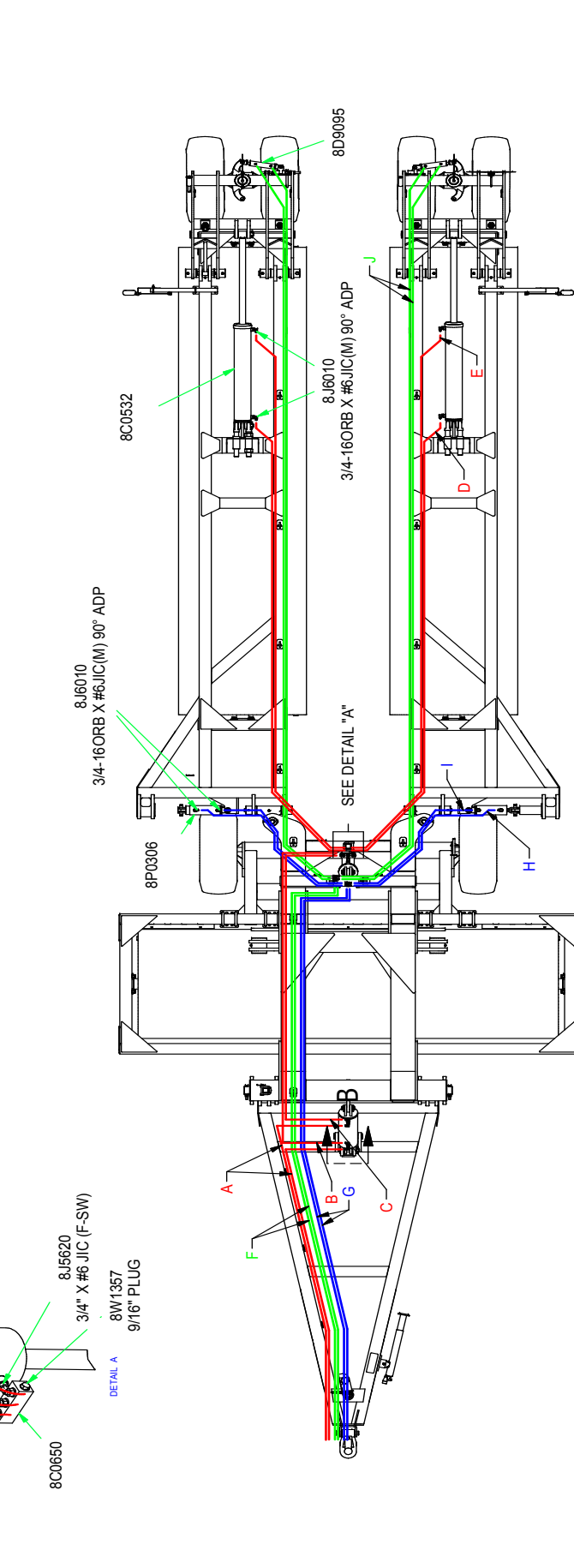
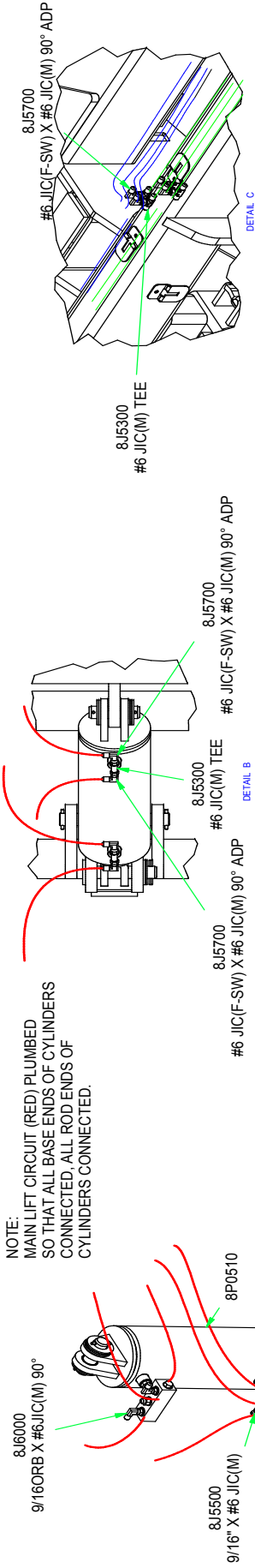

HOSE	34"	41"	46"	53"
A	8N3228	8N3228	8N3228	8N3228
B	8N3156	8N3156	8N3156	8N3156
C	8N3150	8N3150	8N3150	8N3150
D	8N3180	8N3216	8N3252	8N3312
E	8N3204	8N3228	8N3276	8N3330
F	8N3348	8N3348	8N3348	8N3348
G	8N3348	8N3348	8N3348	8N3348
H	8N2088	8N2088	8N2088	8N2088
I	8N2076	8N2076	8N2076	8N2076
J	8N3312	8N3360	8N3390	8N3432

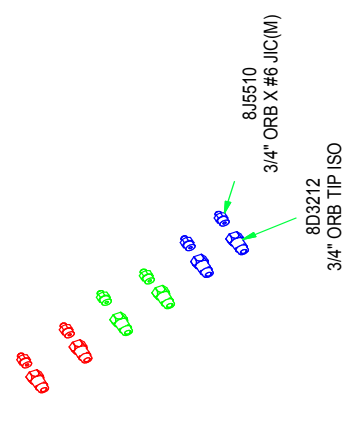



# SUMMERS MFG. CO., INC.

2/28/17

## INSTALLATION AND OPERATION INSTRUCTIONS FOR 8K1800 ACRE METER FOR SUPERROLLER

1. If Roller Shaft is not tapped, weld  $\frac{1}{2}$ "-20 UNF nut at center of left pivot shaft of middle roller. Position external taper of nut toward shaft. Insure that threads are not damaged by weld heat or spatter. Allow weld to cool.
  2. Attach Acre Meter with  $\frac{1}{2}$ " lock washer. Tighten to 260-390 in-lbs.
- \* For accurate logging of acres, it is important that meter is mounted concentrically on roller shaft.
  - \* Do not use chemical agents such as thinner, solvents or mineral spirits to clean Acre Meter cover.
  - \* Do not attempt to open meter! Attempting to do so can cause injury and may destroy Acre Meter.



### CONVERSION FACTOR

NOTE: METER READING MUST BE MULTIPLIED BY CONVERSION FACTOR FOR ACTUAL ACRES.

MACHINE WIDTH	FORMULA
15'	READING x 1.4 = ACRES
21'	READING x 1.9 = ACRES
30'	READING x 2.7 = ACRES
34'	READING x 2.99 = ACRES
41'	READING x 3.6 = ACRES
45'	READING x 4 = ACRES
46'	READING x 4.1 = ACRES
50' (36")	READING x 3.8 = ACRES
53'	READING x 4.7 = ACRES
62'	READING x 5.5 = ACRES
68'	READING x 6.03 = ACRES
84' (36")	READING x 6.5 = ACRES
84' (42")	READING x 7.5 = ACRES
91'	READING x 8.07 = ACRES



<u>Stock Code</u>	<u>Description</u>
8A1155	U-BOLT 3/8 X 6-1/16 X 5" SQ
8A1156	U-BOLT 3/8 X 4-1/16 X 5" SQ
8A1157	U-BOLT 3/8 X 4-1/16 X 7" SQ
8A4048	NYLON TIE .18 X 11"
8A4050	NYLON TIE .30 X 8-7/8"
8A4052	NYLON TIE .30 X 15.25"
8A4054	NYLON TIE .30 X 24" BLK
8C0270	SPLITSTEELBUSH 1.375X 1"ID- 1"
8C0432	HYD CYL 4 X 32" 3000PSI
8C0532HD	HYD CYL 5 X 32" 3500PSI 2.5"SHFT
8C1700	U-BOLT 3/8 X 2 X 4-7/8" SQ
8C1710	U-BOLT 3/8 X 8 X 9" SQ
8C1718	U-BOLT 1/2 X 2-5/8 X 2-5/8" SQ
8C1720	U-BOLT 1/2 X 2-5/8 X 3-3/4" SQ
8C1736	U-BOLT 1/2 X 4-1/4 X 5-1/4"RND
8C1740	U-BOLT 1/2 X 4-1/4 X 7-1/4"RND
8C1755	U-BOLT 3/4 X 6 X 6" SQ
8C1760	U-BOLT 3/4 X 8 X 6" SQ
8C1780	U-BOLT 7/8 X 8 X 10" SQ
8C1900	CLAMP 1/2" WIRE ROPE
8D0330	U-BOLT 5/8 X 6-1/16 X 5-5/8"SQ
8D0340	U-BOLT 3/4 X 4 X 7-3/4" SQ
8D0350	U-BOLT 3/4 X 4 X 10" SQ
8D0720	HITCH PIECE CAST CAT.3CTD PNTD
8D0722	PERFECT HTCH BACKSTOP W/HDWE
8D0724	CLEVIS OPT.HITCH CAT.3CTD99-
8D0730	URETHANE CUSHION PERFCTHTCH
8D0745	HITCH PIECE WELDED CAT.5
8D2440	SAFETY CHAIN 11000# 1/4" X 84"
8D2460	SAFETY CHAIN 20200# 3/8" X 4'
8D2470	SAFETY CHAIN 30400# 7/16" X 5'
8D2730	PIN 1 X 2-3/4" CABLE PLATED
8D3150	U-BOLT 1/2 X 3 X 7-1/4" SQ
8D3152	U-BOLT 1/2 X 3-3/8 X 7-1/4" SQ
8D3212	MALE TIP 3/4"-16 ORB ISO
8D5212	NUT 7/8"-14NF HEX SLOT GR2 PLN
8D5219	WASHER 7/8" AXLE
8D8490	PIONEER/ISO TIP HLDR BNT 97-
8D8500	HYD HOSE HOLDER PNTD BLK 91-
8D8521	JACK SPOOL 3 X 2.56- 1-29/32"
8D8522	JACK 5000# TOP CRANK 15"LIFT
8D8523	JACK 8000# DROPLEG 5/8X4.25PIN
8D9108	ROLL PIN 1/4 X 2" ZINC
8D9109	HYD CYL 4 X 6" BLK ULTRA
8D9110	HAIRPIN CLIP LARGE (1"CYL PIN)
8G2281	NYLON TIE .187 X 7-1/2" BROWN
8G2282	NYLON TIE .187 X 7-1/2" RED
8G2283	NYLON TIE .187 X 7-1/2" ORANGE
8G2284	NYLON TIE .187 X 7-1/2" YELLOW
8G2285	NYLON TIE .187 X 7-1/2" GREEN
8G2286	NYLON TIE .187 X 7-1/2" BLUE
8G8010	U-BOLT 3/8 X 1-5/16 X 2-1/4"SQ
8G8020	U-BOLT 3/8 X 2-9/16 X 3-1/2"SQ
8HD0200	U-BOLT 1/2 X 2-3/8X 3-9/16"RND
8J5100	#6 JIC(M) X #6 JIC(M) UNION
8J5102	#6 ORB TO 3/8" FPT ADAPTR SWVL
8J5110	#10 JIC(M) X #10 JIC(M) UNION
8J5150	3/8" MPT X #6 JIC(M) STR ADPTR
8J5152	#8 JIC(F) X #6 JIC(M) RDCR

<u>Stock Code</u>	<u>Description</u>
8J5	1/2" MPT X #10 JIC(M)STR ADPTR
8J5200	#10 JIC(F) X #6 JIC(M)HEX BUSH
8J5298	TEE #6 SWIVELNUTRUN(M+M+F-SW)
8J5300	TEE #6 JIC (MALE) 3X
8J5312	TEE #10JIC(M2X)X3/4-16ORBBRNCH
8J5500	9/16"-18 ORB X #6 JIC(M) STR
8J5510	3/4"-16 ORB X #6 JIC(M) STR
8J5520	3/4"-16 ORB X #10 JIC(M) STR
8J5540	7/8"-14 ORB X #10 JIC(M) STR
8J5550	1-1/16" - 12ORB X#10JIC(M)STR
8J5600	9/16"-18 ORB X #6 JIC(F-SW)STR
8J5620	3/4"-16 ORB X #6 JIC(F-SW)STR
8J5680	3/4"-16 ORB X 3/4"-16ORB UNION
8J5682	3/4"-16ORB(2X)ADJUSTABLE UNION
8J5690	3/4-16X3/4-16 ORB M-SW90*UNION
8J5700	#6 JIC(F-SW) X #6 JIC(M)90*ADP
8J5710	#10 JIC(F-SW)X#10 JIC(M)90*ADP
8J5800	3/8" FPT X #6 JIC (F-SW) STR
8J5810	1/2" FPT X #10 JIC(F-SW) STR
8J6000	9/16"-18 ORB X #6 JIC(M)90*ADP
8J6002	9/16"-18ORB X #6 JIC(M)BRNCH T
8J6004	9/16"-18ORB X #6 JIC(M)RUN TEE
8J6010	3/4"-16 ORB X #6 JIC(M)90*ADP
8J6020	3/4"-16 ORB X #10 JIC(M)90*ADP
8J6030	7/8"-14 ORB X #10 JIC(M)90*ADP
8J6060	3/4"-16ORB X #6JIC(F-SW)90*ADP
8J7000	BALL VALVE HYD 9/16"-18ORB(2X)
8J7040	THERMAL RELIEF MANIFLD 4000PSI
8J7116	3/4"-16 ORB(2X)1WAY 1/16"RESTR
8J7216	#6JIC(M)X6JIC(F)1/16"RSTR GOLD
8J7232	#6JIC(M)X6JIC(F)1/32"RSTR SLVR
8J7250	RELIEF VLV 2250PSI 9/16"-18ORB
8J7260	DUAL OUTLET FEMALE HYD COUPLER
8K1105	HUB&AXLE ASSY HD812(2.5"RCVR)
8K1105S	HUB&AXLE ASSY HD812 (2"RCVR)
8K1610	PIN 3/4 X 6.25" TRNSPRTLCK 84-
8K1620	PIN 1-1/4 X 6-1/8" 84-
8K7020	WHEEL 15 X 10" 8 BOLT-VLV GRD
8K7028	TIRE 12.5L X 15" LRF TL HWYSRV
8K7037	11L X 15 LRF ON 15X8X8 WHL
8K7042	12.5L X 15 LRF ON 15X10X8 WHL
8K7111	HUB HD812 W/CUPS&ZRK 8BLT3LIP
8K7113	HUB CAP HD812 DC17
8K7117	BEARING INNER HD812 LM3780
8K7118	BEARING OUTER HD812 LM2790
8K7120	SEAL 2-1/2"ID HD812 SE17 -06
8K7122	STUD WHEEL 5/8-18UNFX2.5"97-
8K7123	NUT 5/8"-18UNF WHEEL BOLT 97-
8K7127	SEAL TRPL LIP EXTRNL HD812 06-
8K7128	SEAL SLEEVE FOR 3X LIP 812 06-
8K7130	RACE INNER HD812 LM3720
8K7132	RACE OUTER HD812 LM2720
8K7150	AXLE HD812 X 11.5 (2.5 DIA.)
8K7150S	AXLE HD812X 11.5 (2 DIA.RCVR)
8K7520	IF320/70 15 144D OM 15X10X8 WHL
8K8010	TUBE LGHT BRCKT 1.5SQ PNTD 00-
8K8020	STL 12GA MNTNG BRCKT LIGHT 00-
8K8030A	MODULE AG ENHNCDW/BRAKE6PIN08-
8K8060B	EXT HRNSS 12'6PIN DEUTSCH09-

<u>Stock Code</u>	<u>Description</u>	<u>Stock Code</u>	<u>Description</u>
8K8067	DUST CAP FOR 7PIN CONNECT00-	8N3156	3/8X 156"HYD HOSE #6FJX3000PSI
8K8070B	MAIN HRNSS 7PNLNG W/BRAKE 09-	8N3160	3/8X 160"HYD HOSE #6FJX3000PSI
8K8071	MAIN HRNSS 7PIN 26' W/BRAKE 09-	8N3180	3/8X 180"HYD HOSE #6FJX3000PSI
8K8075A	EXT HRNSS NONDRAWBR DTSCH 07-	8N3204	3/8X 204"HYD HOSE #6FJX3000PSI
8K8079	EXT HARNESS 36' DEUTSCH 16-	8N3216	3/8X 216"HYD HOSE #6FJX3000PSI
8K8080A	EXT HRNSS DRAWBAR DEUTSCH 07-	8N3228	3/8X 228"HYD HOSE #6FJX3000PSI
8K8088	LENS ONLY AMBER GROTE LGHT 00-	8N3252	3/8X 252"HYD HOSE #6FJX3000PSI
8K8090	LIGHT AMBER 2WIREWTHRCK 00-	8N3276	3/8X 276"HYD HOSE #6FJX3000PSI
8K8090A	LIGHT AMBER 2WIRE DEUTSCH 07-	8N3288	3/8X 288"HYD HOSE #6FJX3000PSI
8K8092	LENS ONLY RED GROTE LIGHT 00-	8N3312	3/8X 312"HYD HOSE #6FJX3000PSI
8K8095	LIGHT RED 3 WIRE WEATHRCK 05-	8N3330	3/8X 330"HYD HOSE #6FJX3000PSI
8K8095A	LIGHT RED 3WIRE DEUTSCH 07-	8N3348	3/8X 348"HYD HOSE #6FJX3000PSI
8K8105A	EXT HRNSS T 26'2WIRE DTSCH 07-	8N3360	3/8X 360"HYD HOSE #6FJX3000PSI
8K8200	BRCKT SMV ATTCH 4-8"FRAME98-	8N3390	3/8X 390"HYD HOSE #6FJX3000PSI
8K8202	BRCKT SMV ATTCH BNT45* LR 05-	8N3408	3/8X 408"HYD HOSE #6FJX3000PSI
8K8210	BRCKT W/SCKT SMV ATCH4-8"98-	8N3432	3/8X 432"HYD HOSE #6FJX3000PSI
8K8220	BRCKT LGHT.25X1.75-18.4" 04-	8N3462	3/8X 462"HYD HOSE #6FJX3000PSI
8K9102	PIN 1 X 4" CYL-FOR1/4"ROLL PIN	8N3534	3/8X 534"HYD HOSE #6FJX3000PSI
8K9106	PIN 1-1/4 X 4-3/8" HARDENED	8N3570	3/8X 570"HYD HOSE #6FJX3000PSI
8L0252	WASHER 1.28"IDX4.5ODX 1/4" YZ	8N3606	3/8X 606"HYD HOSE #6FJX3000PSI
8L0256	U-BOLT 1/4 X 1-1/2 X 2-1/2" SQ	8N4016	1/2X 16"HYD HOSE#10FJX3000PSI
8L0258	U-BOLT 5/16 X 1-1/2 X 2-1/2"SQ	8N4060	1/2X 60"HYD HOSE#10FJX3000PSI
8L0260	U-BOLT 3/8 X 1-3/4 X 3" SQ	8N4114	1/2X 114"HYD HOSE#10FJX3000PSI
8L0262	U-BOLT 5/16 X 1 X 2" SQ	8N4120	1/2X 120"HYD HOSE#10FJX3000PSI
8L0266	U-BOLT 1/2 X 3-1/2 X 5" SQ	8N4138	1/2X 138"HYD HOSE#10FJX3000PSI
8L0268	U-BOLT 5/16 X 3 X 4" SQ	8N4160	1/2X 160"HYD HOSE#10FJX3000PSI
8L4628	EYEBOLT 1.5"DIAX1.26"EYE YZ07-	8N4198	1/2X 198"HYD HOSE#10FJX3000PSI
8N2012	1/4X 12"HYD HOSE #6FJX3000PSI	8N4216	1/2X 216"HYD HOSE#10FJX3000PSI
8N2024	1/4X 24"HYD HOSE #6FJX3000PSI	8N4228	1/2X 228"HYD HOSE#10FJX3000PSI
8N2036	1/4X 36"HYD HOSE #6FJX3000PSI	8N4546	1/2X 546"HYD HOSE#10FJX3000PSI
8N2050	1/4X 50"HYD HOSE #6FJX3000PSI	8N4624	1/2X 624"HYD HOSE#10FJX3000PSI
8N2054	1/4X 54"HYD HOSE #6FJX3000PSI	8P0302	HYD CYL 3 X 1.75" 1.25RD 07-
8N2060	1/4X 60"HYD HOSE #6FJX3000PSI	8P0306	HYD CYL 3 X 6"3500P 1.25"RD07-
8N2072	1/4X 72"HYD HOSE #6FJX3000PSI	8P0510	HYD CYL 5.5 X 10" 2"ROD 07-
8N2076	1/4X 76"HYD HOSE #6FJX3000PSI	8P3010	PLUG 2-1/2" NPT SQUARE HD STL
8N2088	1/4X 88"HYD HOSE #6FJX3000PSI	8P3500	TUBE 2.25 X 1.27 ID- 2.25" 05-
8N2096	1/4X 96"HYD HOSE #6FJX3000PSI	8P3900	PIN 2 X 11-1/8" HARDENED
8N2110	1/4X 110"HYD HOSE #6FJX3000PSI	8P3910	PIN 2 X 13-1/2" HARDENED
8N2120	1/4X 120"HYD HOSE #6FJX3000PSI	8P4040	CENTER 41&45' LANDRLLR 05-
8N2135	1/4X 135"HYD HOSE #6FJX3000PSI	8P4067	WING LANDROLLER 13' LEFT 06-
8N2160	1/4X 160"HYD HOSE #6FJX3000PSI	8P4070	WING LANDROLLER 15' LEFT 05-
8N2190	1/4X 190"HYD HOSE #6FJX3000PSI	8P4075	WING LANDRLLR 17.5' LEFT 09-
8N2210	1/4X 210"HYD HOSE #6FJX3000PSI	8P4077	WING LANDROLLER 13' RGHT 06-
8N2248	1/4X 248"HYD HOSE #6FJX3000PSI	8P4080	WING LANDROLLER 15' RGHT 05-
8N2250	1/4X 250"HYD HOSE #6FJX3000PSI	8P4085	WING LANDRLLR 17.5' RGHT 09-
8N2360	1/4X 360"HYD HOSE #6FJX3000PSI	8P4211	ROLLER 42"DIAMETER 11.5' 11-
8N2400	1/4X 400"HYD HOSE #6FJX3000PSI	8P5000	UPRGHT TRNSPRT RST LNDRLLR 05-
8N2410	1/4X 410"HYD HOSE #6FJX3000PSI	8P5020	BRACE TRNSPRT RST LANDRLLR 05-
8N3018	3/8X 18"HYD HOSE #6FJX3000PSI	8P5040	CROSSTUBE TRNSPRT LNDRLLR 05-
8N3028	3/8X 28"HYD HOSE #6FJX3000PSI	8P5060	HITCH LOCK 1/2X3X3.5- 14" 05-
8N3035	3/8X 35"HYD HOSE #6FJX3000PSI	8P5070	WING LOCK 1/2X3X3.5-10.25" 05-
8N3048	3/8X 48"HYD HOSE #6FJX3000PSI	8P5080	REINFORCEMENT ANGLE 7-7/8" 05-
8N3060	3/8X 60"HYD HOSE #6FJX3000PSI	8P6020P	STL 8P6020 10GAX5X8" PNTD 07-
8N3070	3/8X 70"HYD HOSE #6FJX3000PSI	8P6100	LIFTARM W/RCVR SWNGFLD 06-
8N3084	3/8X 84"HYD HOSE #6FJX3000PSI	8P6100S	LIFTARM W/RCVR SWNGFLD SHRT06-
8N3096	3/8X 96"HYD HOSE #6FJX3000PSI	8P6210	CYL ATTCH U-BLT ON 1" ID 06-
8N3124	3/8X 124"HYD HOSE #6FJX3000PSI	8P6211	CVL ATTCH U-BOLT ON 1"ID 06-
8N3136	3/8X 136"HYD HOSE #6FJX3000PSI	8P6215	CYL ATTCH U-BLT ON 1-1/4"ID06-
8N3150	3/8X 150"HYD HOSE #6FJX3000PSI	8P6220	PIVOT HTCH SWNG FLD U-BLT 06-

<u>Stock Code</u>	<u>Description</u>
8P6230	STOP W/RND U-BLT SWNG FLD 06-
8P7000	SCRAPER 36" ROLLER 105" 09-
8P7010	SCRAPER 42" ROLLER 105" 09-
8P7020	SCRAPER 36" ROLLER 34" 09-
8P7022	SCRAPER 42" ROLLER 21.5" 14-
8P7024	SCRAPER 42" ROLLER 25" 11-
8P7025	SCRAPER 42" ROLLER 40" 11-
8P7030	SCRAPER 42" ROLLER 34" 09-
8P7040	SCRAPER 36" ROLLER 68" 09-
8P7050	SCRAPER 42" ROLLER 68" 09-
8P7055	SCRAPER 42" ROLLER 70 7/8" 17-
8P7070	SCRAPER 42" ROLLER 72" 09-
8P7125	MAIN FRAME UPPR TRAIL LR 14-
8P7128	MAIN FRAME LWR 41-53 LR 14-
8P7137	HITCH 41'-53' TRAIL LR 12-
8P7140	PIVOT LOCK 41-84' TRAIL LR 07-
8P7150LB	CASTER WING LEFT 62-84'LR 09-
8P7150RB	CASTER WING RGHT 62-84'LR 09-
8P7155	FRAME TRNSWHL ARM 41-53LR 11
8P7160L	CASTER LEFT 62'-84' LR 07-
8P7160R	CASTER RGHT 62'-84' LR 07-
8P7165BL	TRANSWHL PIVOT 41-53' LR 18-
8P7165BR	TRANSWHL PIVOT 41-53' LR 18-
8P7170	SHOT PIN 41-84' TRAIL LR 07-
8P7182	TRANSFRAME 41'-53' TRAIL LR 11-15
8P7182B	TRANS FRAME 41-53' TRAIL LR 15-
8P7190B	CASTER MOUNT 62'-84' LR 09-
8P7200	SPRING 2.5 OD-1.5 ID-3" 10-
8P7250	EYEBOLT 1.5"DIAX1" EYE1PCYZ
8P7255	PIN 1.5"DIAX1.0625"EYE 1PCYZ
8P7310	LOCK CYL LR PWD COAT RED 07-
8P7395L	WING LEFT 34' TRAIL LR 17-
8P7395R	WING RGHT 34' TRAIL LR 17-
8P7400L	WING LEFT 41' TRAIL LR 11-
8P7400R	WING RGHT 41' TRAIL LR 11-
8P7405L	WING LEFT 46' TRAIL LR 11-
8P7405R	WING RGHT 46' TRAIL LR 11-
8P7410L	WING LEFT 53' TRAIL LR 11-
8P7410R	WING RGHT 53' TRAIL LR 11-
8R8005	SNAP RING .078"FOR 2-1/2"DIA.
8R8010	BEARING 2-1/2"FLNG 4BLT-49/64"
8S0280	U-BOLT 5/16 X 2 X 2-3/4" RND
8S0295	U-BOLT 3/8 X 2-5/8 X 4-1/4"RND
8S0315	U-BOLT 3/8 X 3 X 4-1/8" RND
8S0319	U-BOLT 3/8 X 3 X 4-1/8" SQ
8S0330	U-BOLT 1/2 X 3 X 4-1/4" SQ
8S0340	U-BOLT 1/2 X 4 X 5-1/4" SQ
8S0345	U-BOLT 1/2 X 5 X 6-1/4" SQ
8S0358	U-BOLT 5/8 X 3 X 4-1/2" SQ
8S0360	U-BOLT 5/8 X 6 X 4-1/2" SQ
8S1120	SIGN SLOW MOVING VEHICLE(SMV)
8S1124	MOUNTING SOCKET SMV SIGN
8S1126	MNT SPADE W/HRDWR SMV SIGN
8S2990	HYD HOSE CLAMP-LARGE-NYLON
8T3300	BOLT PIVOT CHSLTRP&WNLFT YZ
8X0000	BOLT 1/4-20X3/4" FLLTHD GR5 YZ
8X0000B	BOLT 1/4-20NC X 1" GR5 YZ
8X0001	BOLT 3/8-16NC X 3/4" GR5 YZ
8X0002	BOLT 3/8-16NC X 1" GR5 YZ

<u>Stock Code</u>	<u>Description</u>
8X0003	BOLT 1/4-20NC X 4-1/2" GR5 YZ
8X0004	BOLT 3/8-16NC X 1-1/4" GR5 YZ
8X0005	BOLT 1/4-20NC X 3-3/4" GR5 YZ
8X0006	BOLT 3/8-16NC X 2-1/2" GR5 YZ
8X0007	BOLT 3/8-16NC X 1-1/2" GR5 YZ
8X0008	BOLT 3/8-16NC X 2" GR5 YZ
8X0009	BOLT 1/4-20NC X 2" GR5 YZ
8X0010	BOLT 1/4-20NC X 1-1/4" GR5 YZ
8X0011	SCREW RDHD SLOT1/4-20X1.5" YZ
8X0013	BOLT 1/4-20NC X 2-1/2" GR5 YZ
8X0014	BOLT 1/4-20NC X 3" GR5 YZ
8X0015	BOLT 3/8-16NC X 3-3/4" GR5 YZ
8X0016	BOLT 3/8-16NC X 3" GR5 YZ
8X0017	BOLT 3/8-16NC X 5" GR5 YZ
8X0019	BOLT 3/8-16NC X 4-1/2" GR5 YZ
8X0020	BOLT 3/8-16X3.5"FULLTHDGR5 YZ
8X0021	BOLT 5/16-18NC X 3/4" GR5 YZ
8X0021A	BOLT 5/16-18NC X 1" GR5 YZ
8X0021B	BOLT 5/16-18NC X 1-1/4"GR5 YZ
8X0022	SCKT CAP 5/16-18 X 1" GR5 YZ
8X0023	BOLT 5/16-18NC X 2" GR5 YZ
8X0030	BOLT 5/16-18NC X 5" GR5 YZ
8X0031	BOLT 7/16-14NC X 1" GR5 YZ
8X0033	BOLT 7/16X1.25 5/8"THD GR5 YZ
8X0034	BOLT 7/16-14NC X 1.75" GR5 YZ
8X0036	BOLT 7/16-14NC X 2" GR5 YZ
8X0038	BOLT 7/16-14NC X 2-1/2"GR5 YZ
8X0041	BOLT 7/16-14NC X 3" GR5 YZ
8X0044	BOLT 7/16-14NC X 3-1/2"GR5 YZ
8X0045	BOLT 7/16-14NC X 4-1/2"GR5 YZ
8X0046	BOLT 7/16-14NC X 7-1/4" GR5 YZ
8X0047	BOLT 7/16-14NC X 6" GR5 YZ
8X0048	CRG 7/16-14NC X 3-1/2" GR5 YZ
8X0061	BOLT 1/2-13NC X 1-1/4" GR5 YZ
8X0062	BOLT 1/2-13NC X 2" GR5 YZ
8X0063	BOLT 1/2-13NC X 1-1/2" GR5 YZ
8X0064	CRG 1/2-13NC X 1-1/2" GR5 YZ
8X0065	CRG 1/2-13NC X 2" GR5 YZ
8X0065L	CRG 1/2-13NC X 3" GR5 ZINC
8X0066	BOLT 1/2-13NC X 1-3/4" GR5 YZ
8X0067	BOLT 1/2-13NC X 2-1/4" GR5 YZ
8X0068	BOLT 1/2-13NC X 2-1/2" GR5 YZ
8X0069	BOLT 1/2-13NC X 3" GR5 YZ
8X0070	BOLT 1/2-13NC X 3-1/4" GR5 YZ
8X0071	BOLT 1/2-13X 3"SHOULDR GR2 YZ
8X0072	BOLT 1/2-13NC X 3-3/4" GR5 YZ
8X0073	BOLT 1/2-13NC X 5" GR5 YZ
8X0074	BOLT 1/2-13NC X 4-1/2" GR5 YZ
8X0075	BOLT 1/2-13NC X 6" GR5 YZ
8X0077	BOLT 1/2-13NC X 7-1/2" GR5 YZ
8X0078	BOLT 1/2-13X3.62" SHLDR GR2 YZ
8X0080	BOLT 1/2-13NC X 11" GR5 YZ
8X0082	BOLT 1/2-13NC X 6-1/2" GR5 YZ
8X0083	BOLT 1/2-13NC X 8" GR5 YZ
8X0084	BOLT 1/2-13NC X 9" GR5 YZ
8X0087	BOLT 5/8-11NC X 1-1/2" GR5 YZ
8X0090	BOLT 5/8-11NC X 2-1/4" GR5 YZ
8X0091	BOLT 5/8-11NC X 1-3/4" GR5 YZ
8X0092	BOLT 5/8-11NC X 2-3/4" GR5 YZ

<u>Stock Code</u>	<u>Description</u>
8X0093	BOLT 5/8-11NC X 2" GR5 YZ
8X0095	BOLT 5/8-11NC X 5" GR5 YZ
8X0096	BOLT 5/8-11NC X 4" GR5 YZ
8X0098	BOLT 5/8-11X 3.5"FULLTHDGR5 YZ
8X0099	BOLT 5/8-11X6.75"W/3.5THDGR5YZ
8X0101	BOLT 5/8-11NC X 8" GR5 YZ
8X0102	BOLT 5/8-11NC X 9" GR5 YZ
8X0106	BOLT 3/4X2.75"W/1.38THD GR8 YZ
8X0107	BOLT 3/4-10NC X 2" GR5 YZ
8X0110	BOLT 3/4-10NC X 1-1/4" GR5 YZ
8X0111	BOLT 3/4-10NC X 2-1/2" GR5 YZ
8X0112	BOLT 3/4-10NC X 2-1/4" GR5 YZ
8X0113	BOLT 3/4-10NC X 5" GR5 YZ
8X0114	BOLT 3/4-10NC X 3" GR5 YZ
8X0115	BOLT 3/4-10NC X 3-1/2" GR5 YZ
8X0115A	BOLT 3/4NCX 3.5"FULLTHD GR5 YZ
8X0115B	BOLT 3/4-10NC X 3-1/2" GR8 YZ
8X0116	BOLT 3/4-10NC X 6" GR5 YZ
8X0117	BOLT 3/4-10NC X 7" GR5 YZ
8X0118	BOLT 3/4-10NC X 4" GR5 YZ
8X0118A	BOLT 3/4-10NC X 4-1/4" GR5 YZ
8X0119	BOLT 3/4-10NC X 7-1/2" GR5 YZ
8X0120	BOLT 3/4-10NC X 9" GR5 YZ
8X0121	BOLT 3/4-10NC X 6-1/2" GR5 YZ
8X0122	BOLT 3/4-10NC X 4-1/2" GR5 YZ
8X0123	BOLT 3/4-10NC X 5-1/2" GR5 YZ
8X0125	BOLT 3/4-10NC X 10" GR5 YZ
8X0128	BOLT 3/4-10NC X 8-1/2" GR8 YZ
8X0130	BOLT 7/8-9NC X 2" GR5 YZ
8X0132	BOLT 7/8-9NC X 2-1/2" GR5 YZ
8X0133	BOLT 7/8-9NC X 3" GR5 YZ
8X0138	BOLT 1-8NC X 5-1/2" GR5 YZ
8X0139	BOLT 1-8NC X 3" GR5 YZ
8X0140	BOLT 1-8NCX7" W/1.5"THDGR5 YZ
8X0141	BOLT 1-8NC X 7.5" GR5 YZ
8X0142	BOLT 1-8NCX3.5" GR5 YZ
8X0143	BOLT 1-8NC X 5" GR5 YZ
8X0145	BOLT 1-8NC X 10-1/2" GR5 YZ
8X0149	BOLT 1-8NC X 18" GR5 YZ
8X0150	BOLT 1-8NC X 20" GR5 YZ
8X0152	BOLT 1-1/4X7NC X 3.75 FULL THRD
8X0201	NUT 3/8"-16NC HEX GR2 YZ
8X0202	NUT 3/8"-16NC NY-LOCK GR2 YZ
8X0203	NUT 3/8"-16NC SERFLANG GR2 YZ
8X0204	NUT 3/8"-16NC HEX GR2 GALV
8X0205	NUT 10-24 HEX YZ
8X0210	NUT 5/16"-18NC HEX GR2 YZ
8X0211	NUT 5/16"-18NC SERFLANG GR2 YZ
8X0212	NUT 5/16"-18NC NY-LOCK GR2 YZ
8X0218	NUT 1/4"-20NC SQ GR2 SS
8X0220	NUT 1/4"-20NC HEX GR2 YZ
8X0222	NUT 1/4"-20NC NY-LOCK GR2 YZ
8X0223	NUT 1/4"-20NC SERFLANG GR2 YZ
8X0232	NUT 7/16"-14NC HEX GR2 YZ
8X0234	NUT 7/16"-14NC NY-LOCK GR2 YZ
8X0240	NUT 1/2"-13NC HEX GR2 YZ
8X0242	NUT 1/2"-13NC NY-LOCK GR2 YZ
8X0244	NUT 1/2"-13NC FLANG TOP LOCK Z
8X0246	NUT 1/2"-13NC SERFLANG GR2 YZ

<u>Stock Code</u>	<u>Description</u>
8X0250	NUT 5/8"-11NC HEX GR2 YZ
8X0251	NUT 5/8"-11NC JAM GR2 YZ
8X0253	NUT 5/8"-11NC NY-LOCK GR2 YZ
8X0256	NUT 5/8"-11NC SERFLANG GR2 YZ
8X0259	NUT 3/4"-10NC JAM GR2 YZ
8X0260	NUT 3/4"-10NC HEX GR2 YZ
8X0261	NUT 3/4"-10NC NY-LOCK GR2 YZ
8X0264	NUT 3/4"-10NC BEVL CNTRLCK YZ
8X0265	NUT 3/4"-10NC CNTRLOCK GR2 YZ
8X0266	NUT 3/4"-10NC SERFLANG GR2 YZ
8X0268	NUT 7/8"-9NC HEX GR2 YZ
8X0269	NUT 7/8"-9NC JAM GR2 YZ
8X0270	NUT 7/8"-9NC CNTRLOCK GR2 YZ
8X0274	NUT 7/8"-9NC FLNG GRF YZ
8X0277	NUT 1"-8NC JAM GR2 YZ
8X0278	NUT 1"-8NC JAM TOPLOCK GR2 YZ
8X0280	NUT 1"-8NC HEX GR2 YZ
8X0281	NUT 1"-8NC NY-LOCK GR2 YZ
8X0282	NUT 1"-14TPI TOPLOCK GR B Z
8X0283	NUT 1-1/4"-7NC JAM GR2 YZ
8X0284	NUT 1-1/4"-7NC HEX GR2 YZ
8X0285	NUT 1-1/2"-6NC HEX GR2 YZ
8X0286	NUT 1-1/2"-6NC JAM GR2 YZ
8X0290	NUT 1-1/4"-7NC HEXSLOT GR2 YZ
8X0300	LOCKWASHER 5/16" YLW ZNC
8X0301	LOCKWASHER 3/8" YLW ZNC
8X0302	LOCKWASHER 7/16" YLW ZNC
8X0303	LOCKWASHER 1/2" YLW ZNC
8X0304	LOCKWASHER 5/8" YLW ZNC
8X0306	LOCKWASHER 3/4" YLW ZNC
8X0307	LOCKWASHER 7/8" YLW ZNC
8X0308	LOCKWASHER 1/4" YLW ZNC
8X0309	LOCKWASHER 1" YLW ZNC
8X0311	LOCKWASHER 1-1/4" YLW ZNC
8X0312	WASHER 1/4" X 1-1/4" FENDER SS
8X0315	LOCKWASHER 1-1/2" YLW ZNC
8X0316	WASHER 1" SAE FLAT YZ
8X0317	WASHER 3/4" SAE FLAT YZ
8X0318	WASHER 3/4"(13/16"ID)FLAT YZ
8X0319	WASHER 17/32"IDX7/8ODX16GA YZ
8X0320	WASHER 3/8"(7/16" ID)FLAT YZ
8X0323	WASHER 5/8" SAE FLAT YZ
8X0325	WASHER 3/4"(13/16"ID)FLAT PLN
8X0327	WASHER 1-1/4" SAE FLAT YZ
8X0328	WASHER 1.312"IDX2.5 OD-1/4" BL
8X0329	WASHER 5/16"(3/8" ID)FLAT YZ
8X0330	WASHER 17/32"ID X 1.25"OD YZ
8X0331	WASHER 15/32"ID X 1.25"OD YZ
8X0332	WASHER 1/4"(5/16" ID) FLAT YZ
8X0333	WASHER HARROW TOOTH YZ
8X0364	WASHER 2.5 IDX3.5 ODX 14GA YZ
8X0368	WASHER 1-1/2" SAE FLAT PLN
8X0370	WASHER 3.016"IDX 3.93"ODX 14GA
8X0380	WASHER 3.06"IDX4.25" X 3/16"
8X0400	HAIRPIN CLIP 1/8 X 1-15/16"
8X0402	HAIRPIN CLIP 1/8 X 2-9/16"
8X0410	COTTER PIN 3/16 X 1" YZ
8X0414	COTTER PIN 1/4 X 2" YZ
8X0415	COTTER PIN 3/16 X 1-1/2"



<u>Stock Code</u>	<u>Description</u>
8X0418	COTTER PIN 5/16 X 2-1/2" YZ
8X0420	CLEVIS PIN 7/16 X 1-3/4" YZ
8X0422	CLEVIS PIN 1/2 X 2-1/4" YZ
8X0425	CLEVIS PIN 1/2 X 3" YZ
8X0428	CLEVIS PIN 1/2 X 5-1/4" YZ
8X0432	CLEVIS PIN 1/2 X 6" YZ
8X0440	CLEVIS PIN 5/8 X 3-7/8" YZ
8X0462	CLEVIS PIN 3/8 X 3" W/HL YZ
8X0520	ROLL PIN 3/16 X 2" ZINC CLEAR
8X0523	ROLL PIN 5/16 X 2-1/2" PLN
8X0605	SET SCRW SQ HD 7/16-14X 1" YZ
8X0614	SET SCRW SQ HD 5/8-11 X 2" PLN
8X0632	SET SCRW SCKT 7/16-14X 1.5" PLN
8X0665	SET SCRW SQ HD 3/4-10X4.5" YZ
8X0708	ZERK 1/4"-28 NF STR YZ
8X0710	ZERK 1/4"-28 NF 90 DEG YZ
8X0721	ZERK 5/16"-24 NF STR YZ
8X0725	ZERK 1/8" MPT STR YZ
8X0727	ZERK 1/8" MPT 90 DEG YZ
8X0728	ZERK STANDOFF 1/8" NPT X 3"
8X0750	PIN XEDN16P8 BOST3/220MA RED
8Z0055	PLATE SERIAL NUMBER UNIVERSL

<u>Stock Code</u>	<u>Description</u>
8Z0070	DECAL "SUMMERS" 1.25 X 6"
8Z0075	TRANSPORT LOCK DECAL
8Z0079	DECAL "SUMMERS" 5 X 20"
8Z0087	DECAL "WARNING" PINCH POINT03-
8Z0101	DECAL "SUMMERS" M94/04/06 2.25X9
8Z0104	DECAL "WARNING" LNDROLLER HITCH
8Z0106	DECAL "DANGER" LNDRLLR TRNSPRT
8Z0132	DECAL ID SUPERROLLER 05-
8Z0202	SUMMERS 3.5" DECAL
8Z0204	SUMMERS 5.5" DECAL
8Z0276	DECAL GENERAL CAUTION 91-
8Z0278	DECAL WHEEL TIGHTENING 96-
8Z0342	DECAL INSTALL CYLINDER LOCKS
8Z0344	DECAL WING DANGER
8Z0346	DECAL ELECTROCUTION-TILLAGE
8Z0800	REFLECTOR AMBER ADHSVBCK98-
8Z0805	REFLCTR REDORANGE ADHSVBK99-
8Z0810	REFLECTOR RED ADHSV-BACK 98-
8Z1000	MANUAL-PAK 3DIA X 11.75" 09-
8Z1082	OPER MAN TRAIL TYPE LNDRLLR 12-
8Z2200	RT8430 DECAL

# History of Summers Manufacturing Co., Inc.

- 1965 – Summers Manufacturing is founded by Harley Summers, who purchases patent rights for Goebel truck and pickup hoists from the Goebel Brothers of Lehr, ND. These hoists, produced in Harley Summers' blacksmith shop the first year, were distributed nationwide by a Cincinnati, Ohio, dealer. With increasing sales, the company soon outgrows the small shop. Summers wins the Herman harrow contract, beginning the company's Herman culti-harrow line. Summers builds a 7,200 square-foot factory in Maddock to meet the demand for truck and pickup hoists, as well as Herman harrows.
- 1969 – Firm incorporates and becomes officially known as Summers Manufacturing Company, Inc.
- 1970 – Summers purchases rights to manufacture/market the Herman Harrow.
- 1973 – Company builds new 20,000 square-foot plant and offices in Maddock, adding a 20,000 square-foot assembly plant in the fall of 1975 (completed in January 1976), bringing total square footage of Maddock factories to 47,000.
- 1977 – Summers introduces the Agri-sprayer, used in conjunction with the Herman culti-harrow to incorporate herbicides and liquid fertilizer.
- 1980 – Company purchases manufacturing and distributing rights to Crown rockpickers from Crown Manufacturers of Regina, Saskatchewan. This forces another expansion project – a 26,000 square foot factory on a 24 acre site in Devils Lake, ND Industrial Park.
- 1981 – Company establishes a branch facility in Regina, Saskatchewan.
- 1982 – Devils Lake plant begins operations in January, manufacturing supersprayers and rockpickers. The Maddock factory begins producing the Superweeder, a combination cultivator and harrow.
- 1983 – Summers buys manufacturing and distributing rights to the Fargo Field Sprayer line from Mid America Steel (formerly Fargo Foundry), Fargo. This field sprayer line is manufactured at the Devils Lake plant. Harley Summers is selected North Dakota's small-businessman of the year by the Small Business Administration.
- 1984 – Herman Diamond Disk, a disk harrow made in a diamond shape to reduce blade breakage from rocks, comes off the assembly line.
- 1985 – Summers signs a contract with Melroe Company of Bismarck to obtain exclusive manufacturing rights to the Melroe harrow line.
- 1989 – Summers purchases TorMaster Company of Hordean, Manitoba, giving the company a line of rolling packer equipment, comprised of harrow packers and hydraulic fold coil packers.
- 1992 – A new engineering office/parts department is added to the Devils Lake factory.
- 1993 – Company adds two new products: a pickup-mounted sprayer with booms of 80 and 90 feet, and the Summers Superharrow, an extra-heavy-duty residue-management tool designed for the minimum and no-till farmer.
- 1994 – a 50 by 125 foot addition to the Maddock factory is completed. Construction begins on a 24,576 square-foot addition to the Devils Lake factory, which enables the company to increase production of truck-mounted and pull-type supersprayers and rockpickers.
- 1996 – 1500 square foot office area added to the Maddock plant. Company introduces Chisel Plow with floating hitch and 700# trip assembly.
- 1997 – 16,800 square foot warehouse in Maddock purchased from local business.
- 1999 - Company introduces the Ultimate suspended boom trailer sprayer with hydraulic folding booms. Additional sizes added to the Chisel Plow line, now ranging from 28' to 54'.
- 2000 - Company introduces the Supercoultter, the innovative solution for excessive field residue management on no-till, minimum-till, and conventional-till farming operations.
- 2001 - Cold storage building completed at Devils Lake. Company extends boom lengths up to 110 feet on the Ultimate Supersprayer.
- 2002 - Company adds a warehouse and service man in Aberdeen, SD.
- 2003 - Company introduces the Ultimate NT Supersprayer featuring a bolt on axle for easier adjustment, and a new family of tanks that feature a drainable sump and a common width dimension.
- 2004 - A 124 ft. x 310 ft. addition is added onto the current Devils Lake plant.
- 2005 - The Summers Superroller is added to the "Field Tested Tough" product line. Additional sizes of 56', 58' and 60' are added to the Superchisel line. Ultimate-Ultra NT Supersprayer introduced featuring 120' & 133' booms.
- 2006 - The Summers Coulter-Chisel, Rolling Choppers and 30' Superroller were included in product line.
- 2007 - 62' & 84' 5 Section Landrollers and a 20' Coulter-Chisel were introduced.
- 2008 - Disk-Chisels, ranging from 16' to 40' widths, are added to product line.
- 2009 – M105 and M108 Mounted Harrows added to selection of Mounted Attachments. SuperHarrow 2650, 50' SuperCoulter, Hydraulic Fold Rolling Chopper and 36" diameter Landrollers introduced.
- 2010 – Rolling Basket and 47' Diamond Disk added to product line. A 124 ft. x 310 ft. addition to Devils Lake factory built for a state of the art paint system.
- 2011 – Additional Supercoulter sizes were added along with larger tires for tillage implements. Ultimate and Ultra Supersprayers received an additional tank size of 1650 gallons. Front Caster Wheel option was made available for chisel implements.
- 2012 – 41', 46' & 53' Trail Type Landroller added to product line. Additional Superchisel sizes of 16' & 20' were added.
- 2013 – DT9530 added to product line. Internal Scraper in Rolling Baskets introduced. Finishing Coulter Gang becomes standard on the Diamond Disk and 2510 DT. Corporate offices opened at Devils Lake plant. New building and location for the Aberdeen warehouse.
- 2014 – Introduced the VRT2530 (Variable Rate Tillage).
- 2015 – Introduced the VT Flex Applicator and Spray Fill Xpress.
- Summers distributes on a wholesale level to dealers and distributors throughout markets in North Dakota, South Dakota, Minnesota, Montana, Iowa, Washington, Idaho, Oregon, Utah, Colorado, Kansas, Nebraska, Oklahoma, Texas, Manitoba, Saskatchewan, Alberta, British Columbia, Kazakhstan, Russia and Australia, making it an international company.

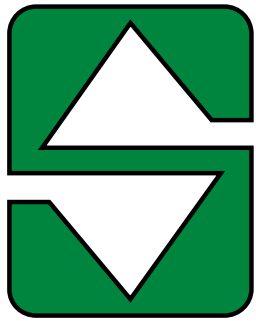

# **SUMMERS<sup>®</sup>**

*... Field Tested TOUGH!*



## **Tillage**



## **Rock Picker**



## **Land Rollers/Packers**



## **Cultivators/Harrows**



## **Mounted Attachments**



## **Sprayers**

