

DIAMOND DISK & DT9530

DIAMOND DISK & DT9530

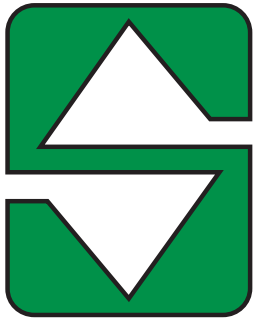

SUMMERS[®]

Operator's Manual

DT9530 &

DK9630

DISK MODELS

IMPORTANT

THE OPERATOR IS RESPONSIBLE FOR ADJUSTING THE MACHINE SINCE MACHINE DOES NOT COME "FIELD READY" FROM FACTORY.



CAUTION

READ & UNDERSTAND OPERATOR'S MANUAL BEFORE USING MACHINE.

See www.summersmfg.com for latest version of all Summers Operator's Manuals.

SUMMERS MANUFACTURING CO., INC.

WEB SITE: www.summersmfg.com

DEVILS LAKE, NORTH DAKOTA 58301

(701) 662-5391

Warranty

Summers warrants only products of its manufacture against operational failure caused by defective materials or workmanship which occur during normal use within 36 months from the date of purchase by the end user from Summers' dealer.

Summers' obligation is to replace free of charge any part of any product that Summers inspection shows to be defective excluding transportation charges to Devils Lake, ND and return and also excluding all transportation costs from Summers' dealer to the dealer's customer and all other costs such as removal and installation expense.

Summers shall not be liable for loss of time, manufacturing costs, labor, material, loss of profits, consequential damages, direct or indirect, because of defective products whether due to rights arising under the contract of sale or independently thereof, and whether or not such claim is based on contract, tort or warranty.

Written permission for any warranty claim return must be first obtained from authorized Summers' personnel. All returns must be accompanied with a complete written explanation of claimed defects and the circumstances of operational failure.

Written warranty for all component parts used in the manufacture of Summers products is available upon request. Warranty of such component parts will be determined by said component manufacturer upon their inspection of the claimed defective part.

This express warranty is the sole warranty of Summers. There are no warranties, which extend beyond the warranty herein expressly set forth. The sales for products of Summers under any other warranty or guarantee express or implied is not authorized. This warranty voids all previous issues.

SUMMERS MANUFACTURING CO. INC.
DEVILS LAKE, NORTH DAKOTA 58301

01/16

GENERAL INFORMATION

This book is composed of four basic sections: Safety, Assembly, Operation and Maintenance, and Parts. The Assembly Section provides complete instructions for the proper assembly of your Summers DIAMOND DISK & DT9530. The Operation Section provides information for the proper operation and maintenance of your Summers DIAMOND DISK & DT9530. A complete parts breakdown is provided in the Parts Section.

Parts are referenced in each drawing with the Summers Manufacturing Part Number. Use this Part Number when ordering replacement parts from your Summers dealer. See back section of manual for description of each Part Number.

Reference to "Right" and "Left" in this book is determined when the machine is viewed from the rear.

It is the policy of this company to improve its products whenever possible and practical to do so. We reserve the right to make changes or improvements in the design or construction of parts at any time without incurring the obligation to install such changes on products previously delivered.

Summers Manufacturing Company, Inc. strongly recommends that each DIAMOND DISK & DT9530 Operator READ and UNDERSTAND the Operator's Manual before using the machine. In addition, this Operator's Manual should be REVIEWED at least ANNUALLY thereafter.

Scan code to the right for the latest version of all Summers Operator's Manuals.



SECTION CONTENTS



Section 1: SAFETY

Section 2: ASSEMBLY INSTRUCTIONS

Section 3: OPERATION, MAINTENANCE AND SPECIFICATIONS

Section 4: PARTS

Section 5: PART NUMBERS & DESCRIPTIONS

OWNER REGISTER

Name _____

Size _____

Address _____

Serial Number _____
(located by the hitch piece)

City _____

State/Prov. _____

Date Purchased _____

Mail Code _____

Dealer _____

TABLE OF CONTENTS

SECTION 1 - SAFETY

Safety-Alert Symbol & General Safety Practices.....	1-1
Safety Decals	1-2 - 1-8

SECTION 2 - ASSEMBLY

General Assembly Safety Practices	2-1
General Assembly - All Units	2-2 – 2-3
16' Units.....	2-4 – 2-10
21' Units.....	2-11 – 2-19
25'-28.5' Units.....	2-20 – 2-28

SECTION 3 - OPERATION & MAINTENANCE

Start-Up	3-1
Hydraulic Operation and Maintenance	3-1
Field Operation	3-2 – 3-3
Storage, Troubleshooting and Dimensions.....	3-4 – 3-5
Bolt Torque Specifications	3-6

SECTION 4 - PARTS

Depth Control Hydraulics.....	4-1 – 4-2
Main Frame	4-3
25' - 28.5' Wing.....	4-4
21' Hydraulics Wing Lift	4-5
25' - 28.5 Hydraulics Wing Lift	4-6
Hydraulic Rear Coulter	4-7
Gang Layouts	4-8 – 4-11
Rear Coulter Gang	4-12 – 4-13
Gang Components	4-14
Mounted Rolling Basket.....	4-15 – 4-18
Mounted Harrow	4-19 – 4-22
8K9250 Wing Weight Package.....	4-23
Light Kit	4-24
Hub and Axle Components	4-25
Mounted Attachment Components	4-26 – 4-28
8K1850 - Acre Meter.....	4-29

SECTION 5 - PART NUMBERS & DESCRIPTIONS..... 5-1 – 5-3

TRANSPORT SAFETY

1. Road speed should not exceed 20 mph (32 km/hr).



2. Do not tow if the implement's towing vehicle ratio is greater than 1.5:1. See Specifications Section for implement weights.
3. If more than one implement is to be pulled by a towing vehicle, it is recommended that each implement is to be a maximum of 50% of the weight of the preceding implement. If it is not possible to reach this weight limit, transport the implements separately.
4. When approaching rough roads/ground (such as entering a road), slow down to a safe driving speed.
5. Check all lights and reflectors to ensure ALL regulations are met. Make sure the SMV emblem is attached to the implement and is clearly visible from the rear.



SMV emblems are only attached to vehicles traveling slower than 25 mph (40 km/hr). The most hazardous conditions to drive in are a daybreak and dusk. The use of a pilot car is recommended.

6. Always install ALL safety locks before transporting an implement.
7. Always park implements on a firm, level surface.

SECTION 1 -  SAFETY

SAFETY-ALERT SYMBOL



This symbol is used to denote possible danger and care should be taken to prevent bodily injury. This symbol means:

**ATTENTION! BECOME ALERT!
YOUR SAFETY IS INVOLVED!**

Definition of each **Signal Word** used in conjunction with the **Safety-Alert** symbol.



indicates an imminently hazardous situation which, if not avoided, will result in death or serious injury. This signal word is limited to the most extreme situations.



indicates a potentially hazardous situation which, if not avoided, could result in death or serious injury.



indicates a potentially hazardous situation which, if not avoided, may result in minor or moderate injury. It may also be used to alert against unsafe practices.

GENERAL SAFETY PRACTICES

1. READ AND UNDERSTAND Operator's Manual before using machine. Review at least annually thereafter.
2. VERIFY all safety devices and shields are in place before using machine.
3. KEEP hands, feet, hair and clothing away from moving parts.
4. STOP engine, place all controls in neutral, set parking brake, remove ignition key and wait for all moving parts to stop before servicing, adjusting or maintaining.
5. BE CAREFUL when working around high pressure hydraulic system.
6. DO NOT ALLOW RIDERS.

SAFETY DURING TRANSPORT

1. ONLY TOW at a safe speed. Use caution when making corners and meeting traffic.
2. USE safety chain between tractor drawbar and implement hitch when transporting on public roads.
3. ALWAYS use transport locks when transporting on public roads.
4. COMPLY with local lighting, marking and oversize regulations when transporting on highways.
5. FREQUENTLY check for traffic from rear, especially during turns.

SECTION 1 -  **SAFETY**

SAFETY DECALS

- A. KEEP SAFETY DECALS CLEAN.
- B. REPLACE missing or unreadable decals. New decals are available from your Summers dealer by ordering correct part number (PN) located on decal.
- C. Locations shown on Page 1-6.

1. TRANSPORT LOCK WARNING DECAL (PN 8Z0075)



2. GENERAL CAUTION DECAL (PN 8Z0276)

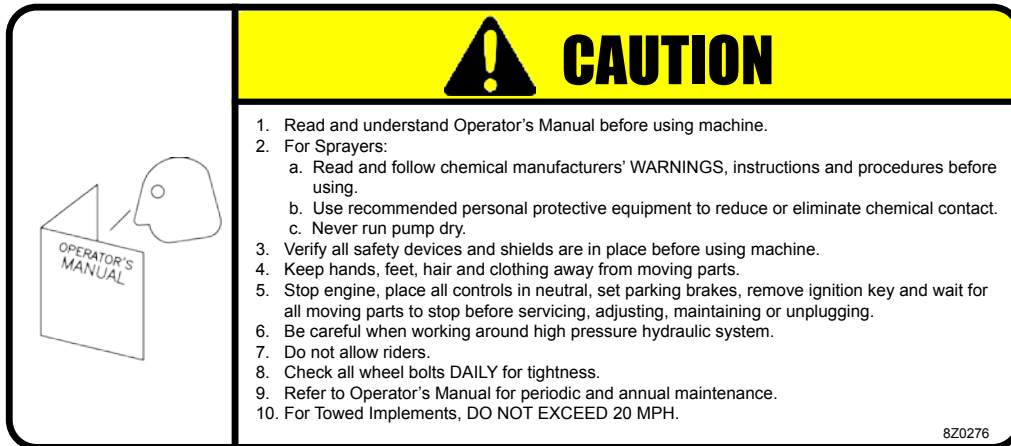

3. REPHASING CYLINDERS DECAL (PN 8Z0340)

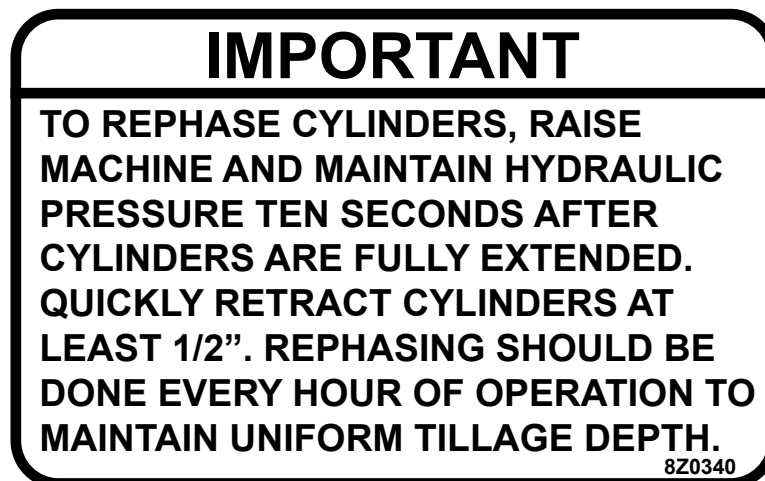

SECTION 1 -  SAFETY

4. INSTALLING CYLINDER LOCKS DECAL (PN 8Z0342)



5. STAYING CLEAR OF WINGS DECAL (PN 8Z0344)

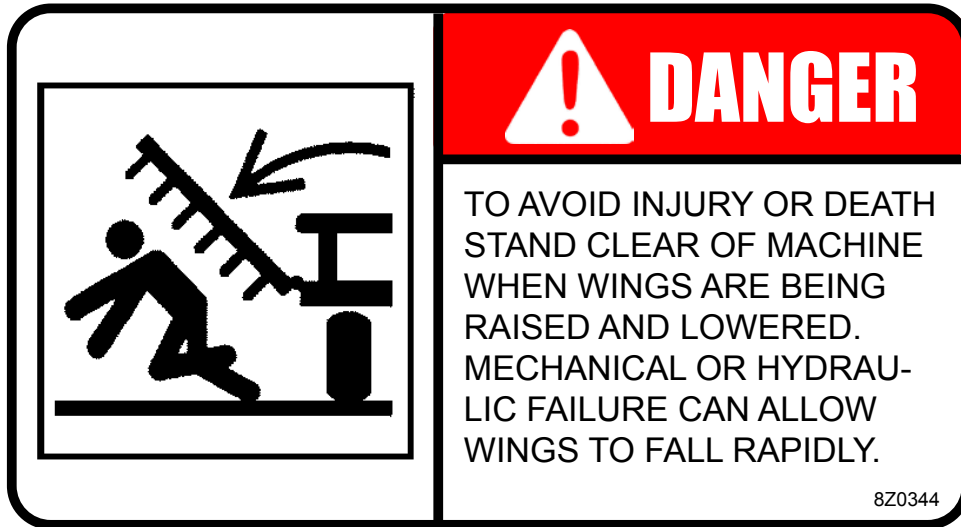

6. ELECTROCUTION DANGER DECAL (PN 8Z0346)

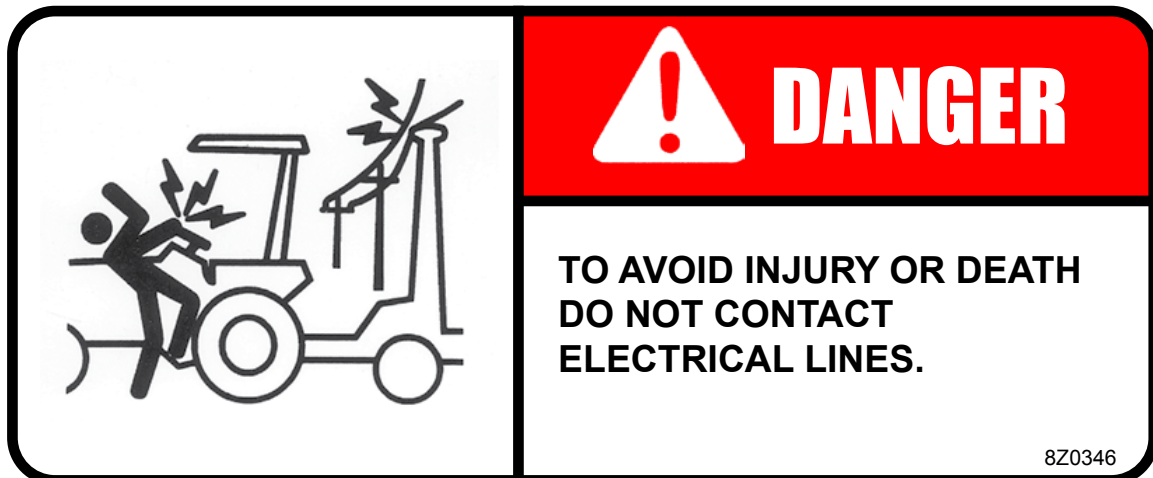

SECTION 1 -  SAFETY

7. PINCH POINT DECAL (PN 8Z0087)

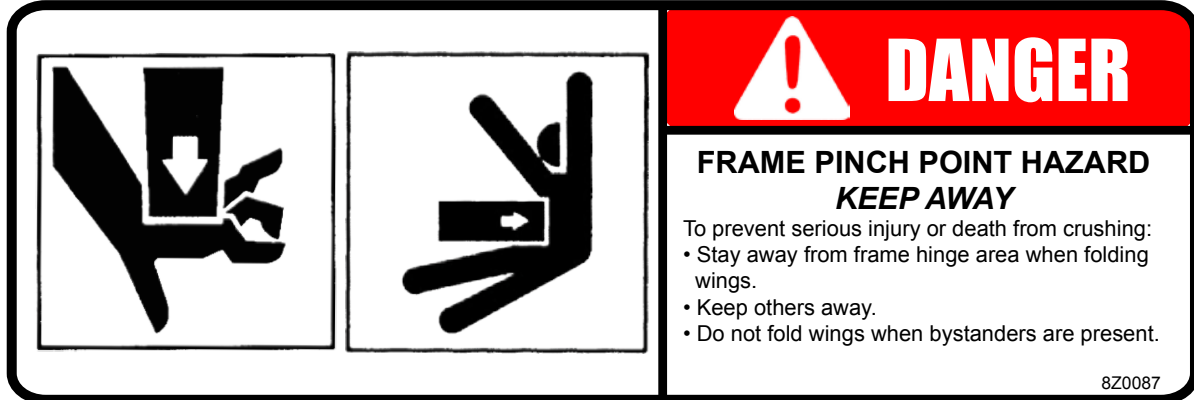

8. SUMMERS DECAL (8Z0204)



9. GANG BEARING GREASE (PN 8Z0350)

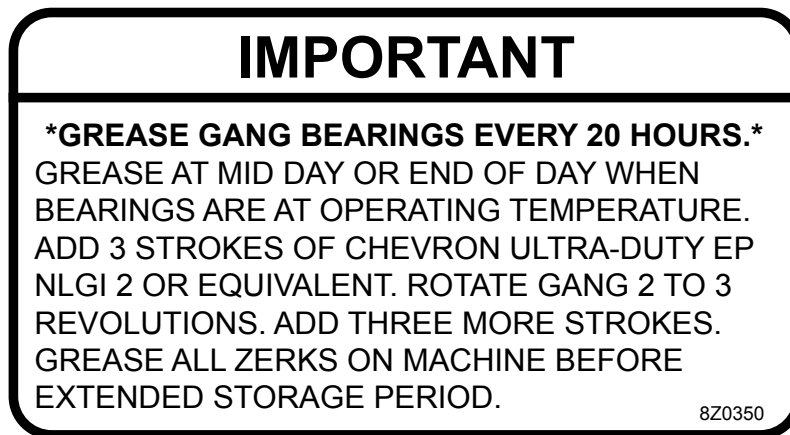

10. AMBER REFLECTOR (PN 8Z0800)

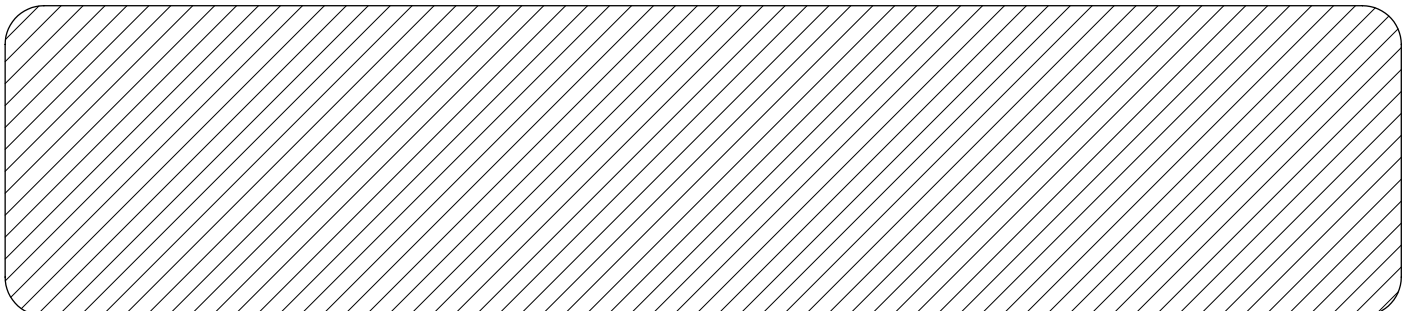

SECTION 1 -



SAFETY

11. RED-ORANGE REFLECTOR (PN 8Z0805)

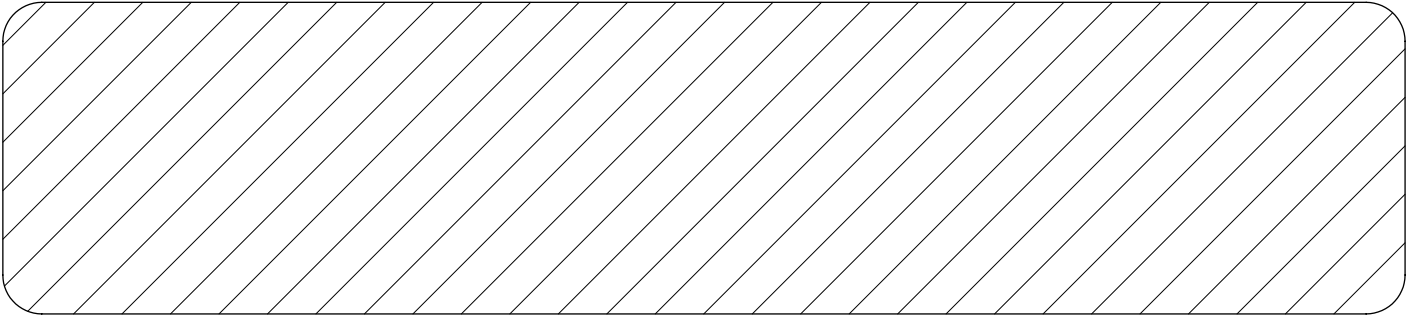

12. RED REFLECTOR (PN 8Z0810)

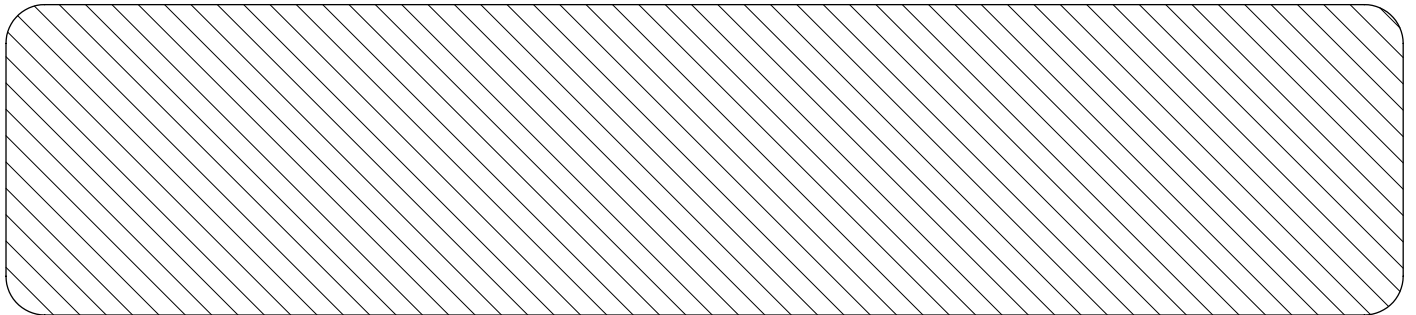

13. DK9630 DECAL (8Z2255)

DK9630

13. DT9530 DECAL (8Z2290)

DT9530

SAFETY LIGHT OPERATION

The Summers Safety Light Kit is equipped with a 7 pin connector. To protect 7 pin connector, store in dust cap (8K8067) when not attached to towing vehicle.

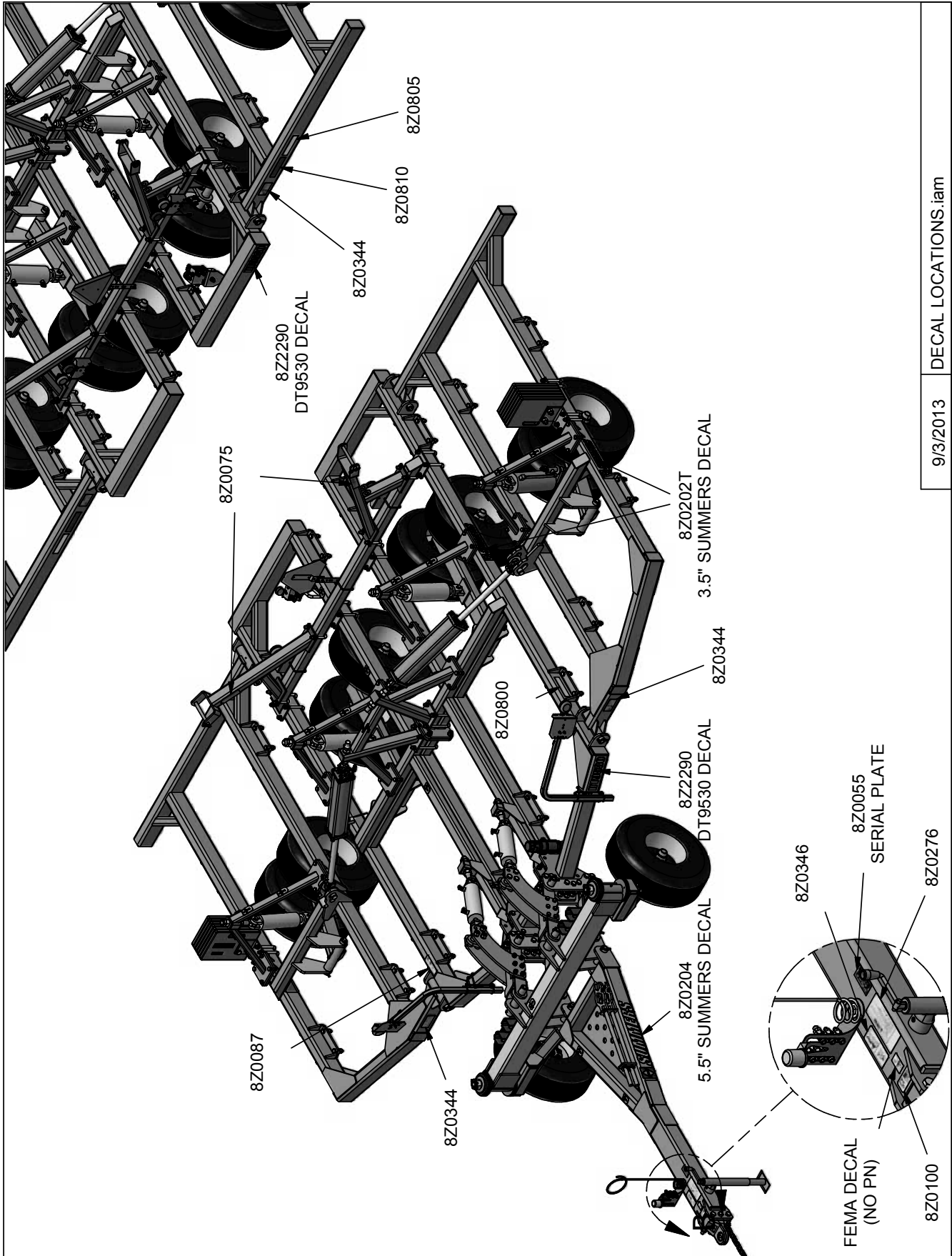

9/3/2013

DECAL LOCATIONS.iam

SECTION 1 -  SAFETY



Front Left Caster



Rear Lights

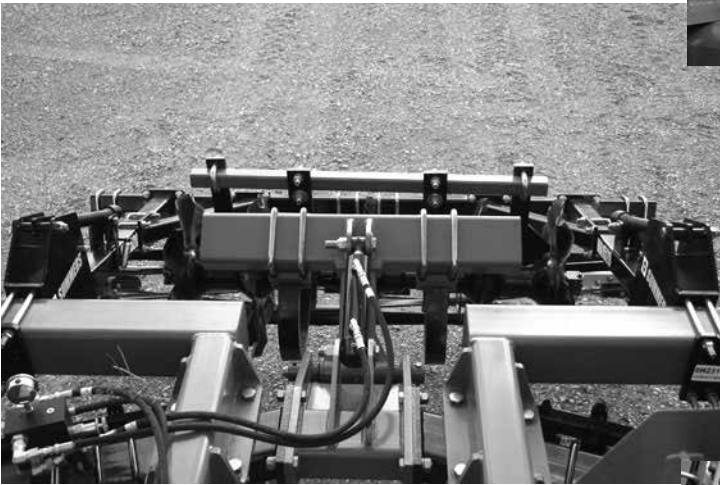

Rear Center

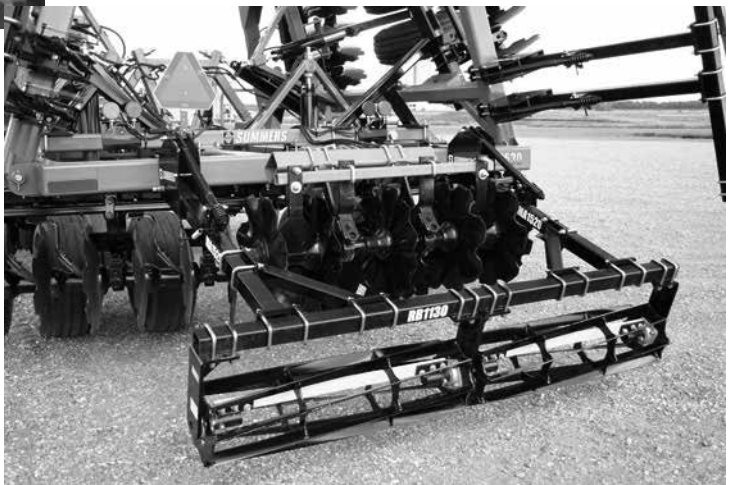

Rear

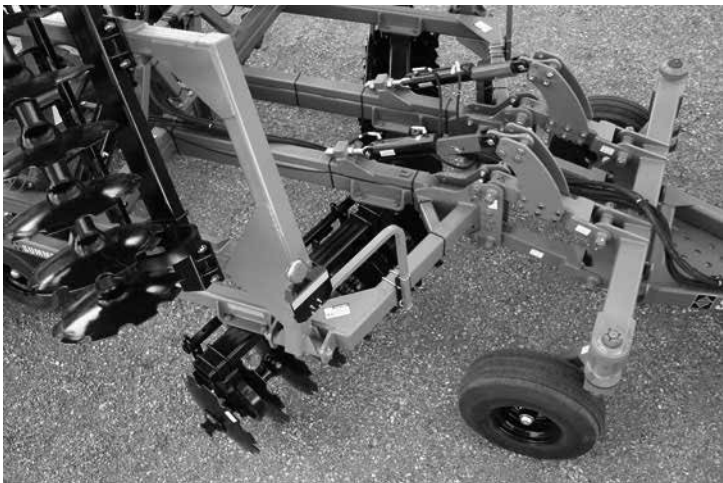

Front



Rear Coulters Gang Hyd. Valve

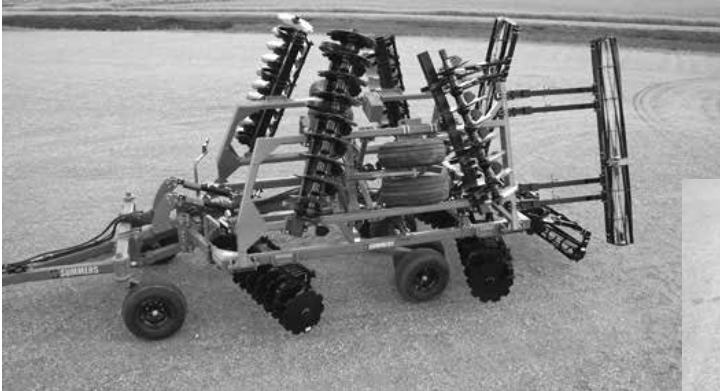

Side View

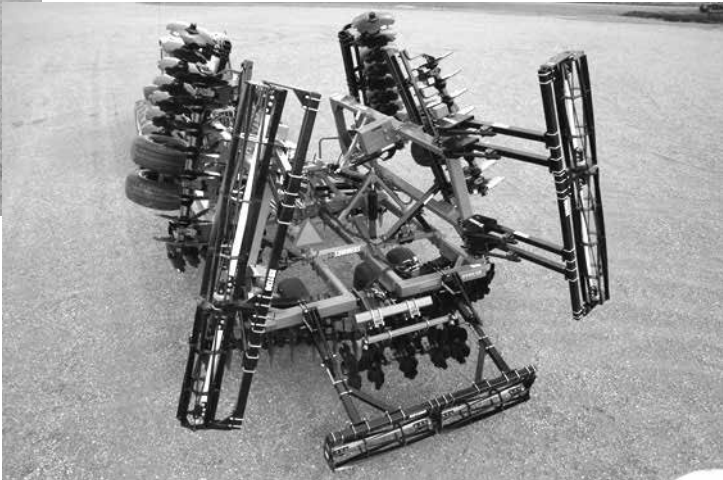

Rear View

GENERAL ASSEMBLY SAFETY PRACTICES



YOU ARE RESPONSIBLE for the safe assembly of the machine.



BLOCK UP ANY RAISED PART of the machine. Be sure machine is stable after blocking.



DO NOT ALLOW CHILDREN or other unauthorized persons within the assembly area.



ALWAYS INSPECT LIFTING CHAINS AND SLINGS for damage or wear.



WEAR PERSONAL PROTECTIVE EQUIPMENT which includes a hard hat, eye protection, work gloves and steel toed boots with slip resistant soles.



BE SURE LIFTING DEVICE IS RATED TO HANDLE THE WEIGHT.



DO NOT MODIFY the equipment or substitute parts in any way. Unauthorized modification may impair the function and/or safety of the machine.



STOP ENGINE, place all controls in neutral, set parking brakes, remove ignition key and wait for all moving parts to stop before servicing or adjusting.



USE SUITABLE LIFTING DEVICE for components which could cause personal injury.



BE SURE PRESSURE IS RELIEVED from hydraulic circuits before servicing or disconnecting from tractor.



USE EXTREME CARE when assembling, servicing or adjusting.

ASSEMBLY INSTRUCTIONS FOR 16 FT. - 28.5 FT.

Refer to illustrations and follow these steps when assembling.

The machine should be placed in an area that allows ample room for assembly in the field position.



CAUTION: For safety purposes, always block equipment while working on it.

MAIN FRAME:

Refer to pages 2-4 thru 2-28 and Parts Section when assembling main frame.

Place left and right center frames on stable supports approximately 3 feet off floor. Bolt center frames together using front splice tube and rear cross tube.

LIFT ARMS

Install lift arm assemblies on center and wings using 1-1/2" dia. x 15-1/2" pins and secure with 7/16" x 3-1/2" bolts and locknuts.

WALKING TANDEM ASSEMBLIES (Rear Center Only)

Check inside surface of walking tandem assemblies (8T4132). A 3-3/4" diameter surface around the 1-1/2" dia. pivot hole must be smooth and burr-free. Remove any welding spatter or roughness prior to further assembly. Install snap rings (8K1920) past grooves of lower pivot tube on the rear center lift arm assemblies. Install V-seal over lower pivot tubes until solid side is against snap ring. Protect lip of V-seal during assembly.

Install walking tandem assemblies to the bottom of rear center liftarms. Mount so axle closest to the center of machine is towards rear. Insert pivot pin (8T3620) through walking tandem assembly and lift arm. Retain with 7/16" x 3-1/2" bolts and locknuts. Push V-seal against walking tandem assembly and secure by placing snap ring into groove.

WHEELS

Insert axle and hub assemblies. Apply good quality anti-seize to axles before inserting into receiver tubes. Retain with 1/2 x 3-3/4" bolts and locknuts in outside position. Install wheel and tire assemblies, retain with 5/8" wheel nuts (torque required: 240 ft-lbs).

A-FRAMES

Mount A-Frame assemblies above lift arm assemblies as shown.

Install the adjustable cylinder bolts next. Set nuts so bolts are in the middle of the adjustment. Insure that cylinder attach holes are aligned when eye bolts are tightened. These will be readjusted later.

WING LOCKS

Install Locks on rear cross tube, slide as far away from center as possible, tighten hardware.

MAIN LIFT HYDRAULIC SYSTEM

Refer to page 4-1 or 4-2 when assembling the main lift hydraulic system.

Attach cylinders to adjustment bolts and lift arms as shown. Note the different sized cylinders. Cylinders must be in their proper location. Install all fittings into cylinders. Route hoses as shown. Use clamps provided to secure hoses to frame. Tighten hose hold-down clamps enough to retain hoses but loose enough that clamps can be turned by hand. Hydraulic hoses will expand and shorten when pressurized. Tighten all fittings.

IMPORTANT: Allow enough hose at hinge points to avoid pinching or stretching the hose.

SECTION 2 - ASSEMBLY

WING LIFT HYDRAULIC SYSTEM

Refer to page 4-5 or 4-6 when assembling the wing lift system. Mount lift cylinders to adjustment bolts and route hoses as shown. **NOTE: CYLINDER PORTS MUST BE FACING DOWN.** Fill lift cylinders with oil before attaching lift linkage. Position adjustment bolts by starting end nuts so they are flush with bolt. Once lift cylinders have been filled with oil and cycle smoothly, connect wing lift linkage. Adjust eye bolts after gangs have been mounted.



CAUTION: Stand clear whenever raising or lowering wings.

HITCH

Attach hitch using (2) 1-1/2" dia. x 10-5/8" pins and secure with 7/16" x 3-1/2" bolts and locknuts.

GANG MOUNTING

Refer to gang layout on page 4-8 through 4-11.

On Diamond Disk position gangs so notched blades are located at rear center of disk.

Start from the center and work towards the outside when hanging gangs. Lift gang up to the frame close to the correct location. Secure with 7/8" x 3" bolts, lock washers and locknuts.

MOUNTING WEIGHT PACKAGE

Mount weight packages on outside of wings in location that will not interfere with disk gang or tire travel. Install 1/2 weight packages (6 suitcase weights with mounting angles and hardware) by positioning mounting angles 8-1/2" apart. Secure with 3/4" U-bolts, lockwashers and nuts. Fully tighten hardware on one mounting angle. Hand tighten mounting hardware on second mounting angle, this must be free to slide. Insert one 1" x 10-1/2" bolt through both mounting angles, turn 1" nut onto this bolt until threads are flush with outside of nut. Spread mounting angles as much as 1" bolt and nut will allow. Lift suitcase weights (8K9230) into position, slide slotted hole of weight over 1" bolt. Continue to slide weight past corner of slot until it reaches the end of the slot, at this location the hole without slot will line up with the second hole in the mounting angles. Repeat procedure with remaining suitcase weights. Insert second 1" x 10-1/2" bolt through angles and weights. Secure second 1" bolt with lockwasher and nut, fully tighten. When second 1" bolt is tight, remove the nut from first bolt and add the lockwasher. Fully tighten all remaining nuts.

Caution: Each suitcase weight (8K9230) weighs 70#. use extreme care when handling them.

SAFETY

Install SMV mounting bracket at machine center. Install remaining decals at locations shown on page 1-6. Install Safety Light Kit, refer to breakdown on page 4-24.

MOUNT REAR ATTACHMENT (OPTIONAL)

See Page 4-15 or 4-22.

SECTION 2 - ASSEMBLY

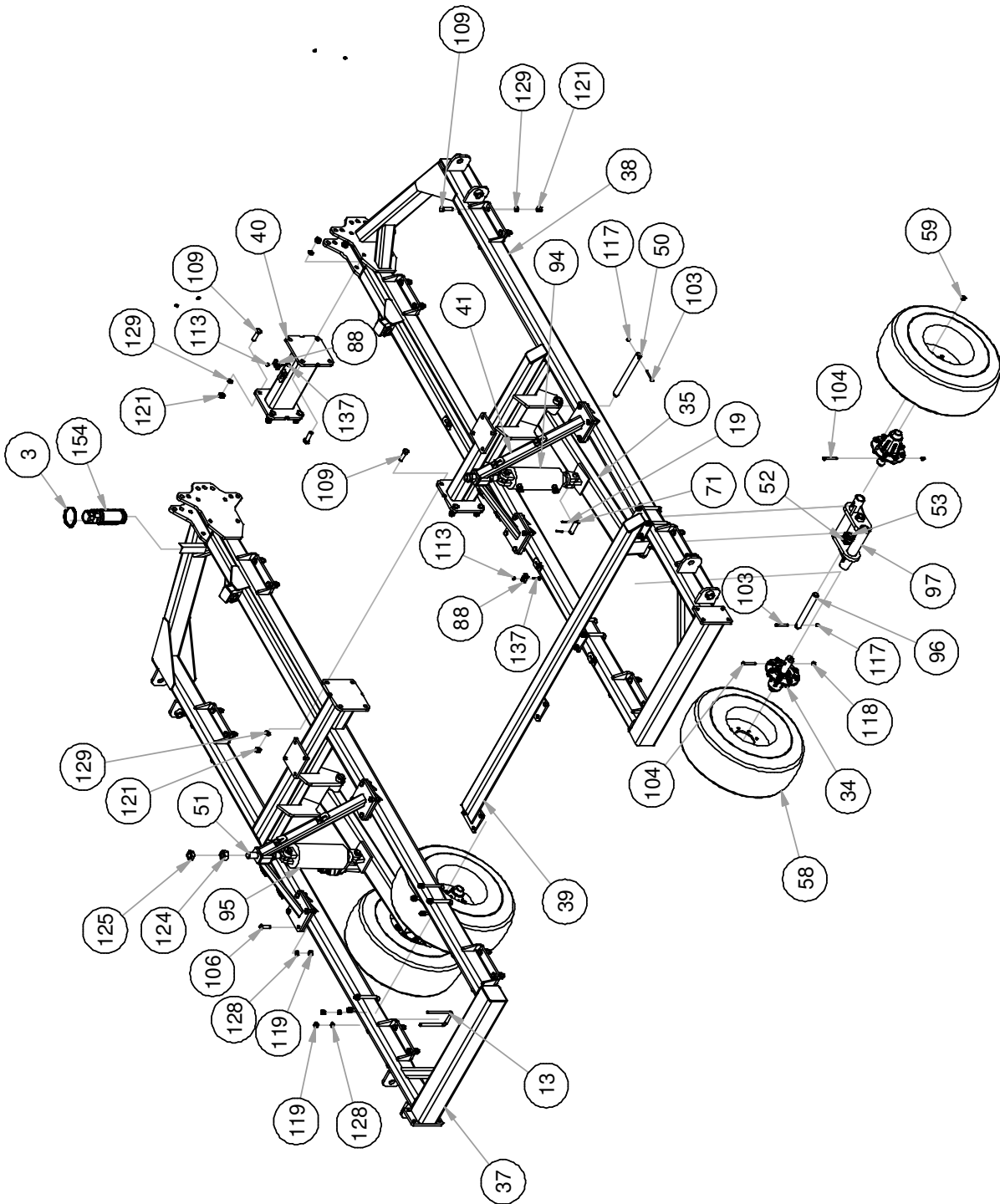

8K3516.iam/FRAME PKG 16' N-DSK

3/10/2015

SECTION 2 - ASSEMBLY

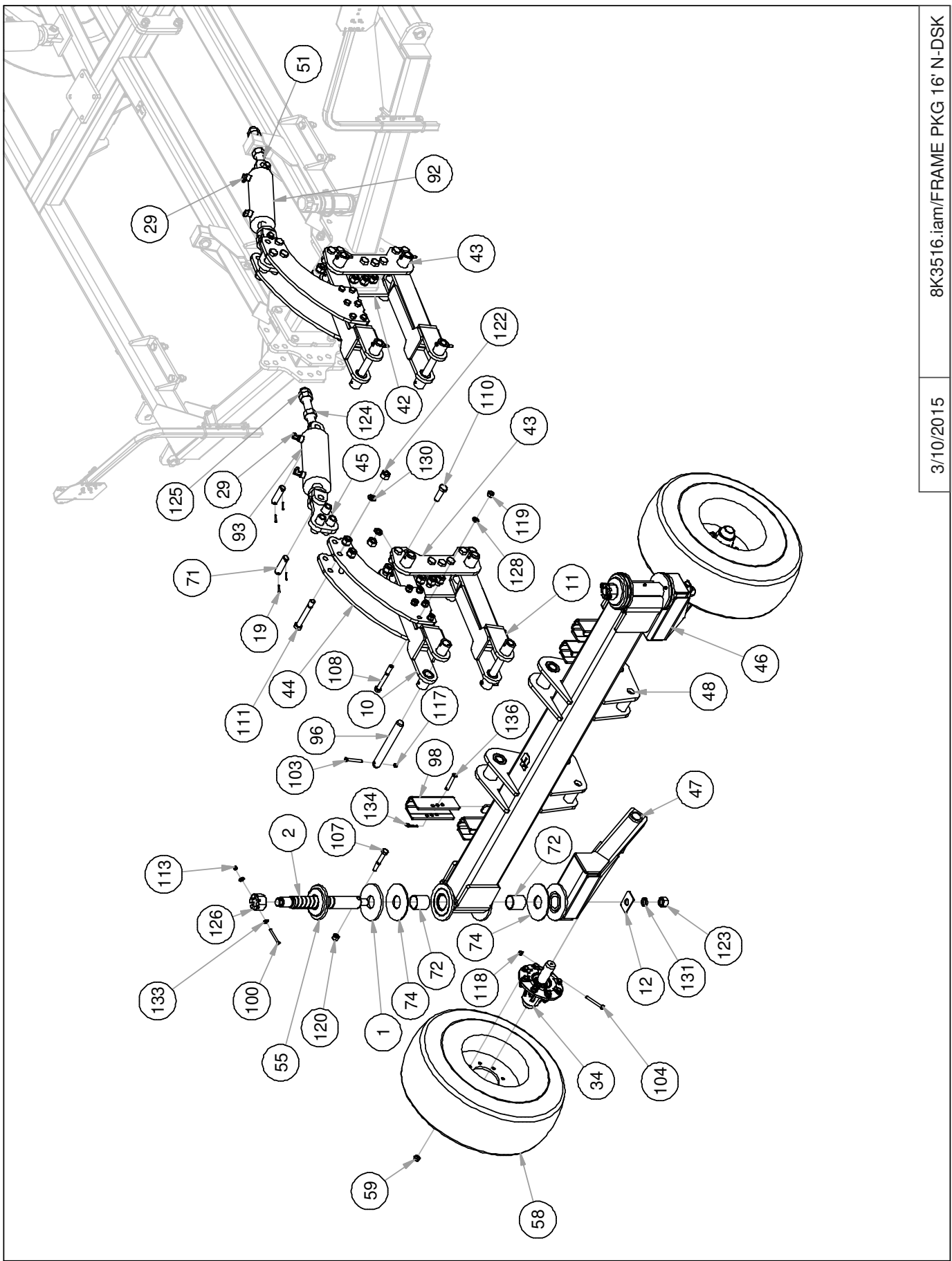

8K3516.iam/FRAME PKG 16' N -DSK

3/10/2015

SECTION 2 - ASSEMBLY

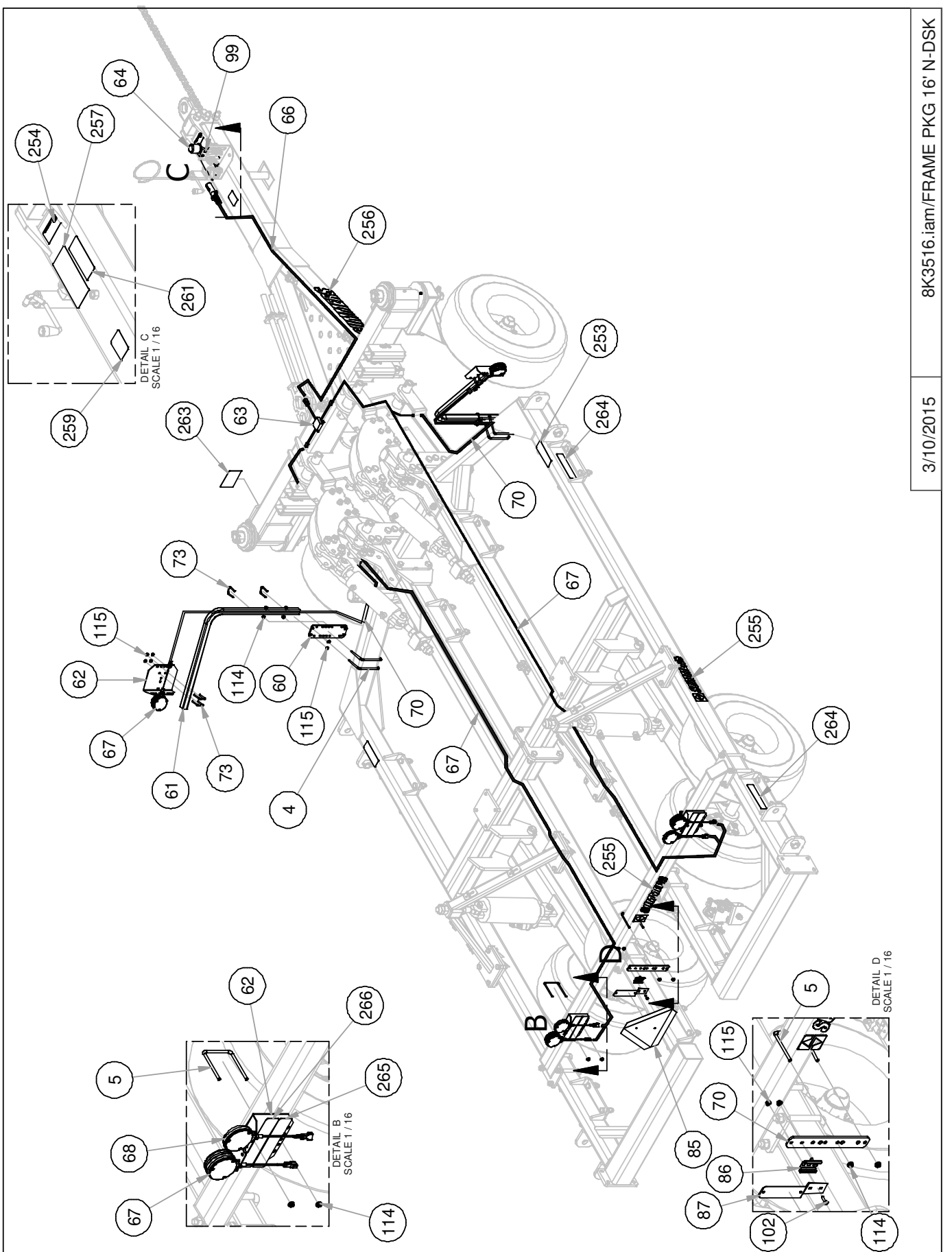

8K3516.iam/FRAME PKG 16' N-DSK

3/10/2015

REAR COULTER HYDRAULICS

NOTE:
 BLOCK IS CONFIGURED FOR
 USE ON TRACTORS WITH
 CLOSED-CENTER HYDRAULIC
 SYSTEMS. FOR USE ON
 OPEN-CENTER HYDRAULIC
 SYSTEMS, HEX PLUG MUST
 BE MOVED FROM CP1 TO
 CP2, AND HOLLOW HEX
 PLUG MOVED FROM CP2
 TO CP1.

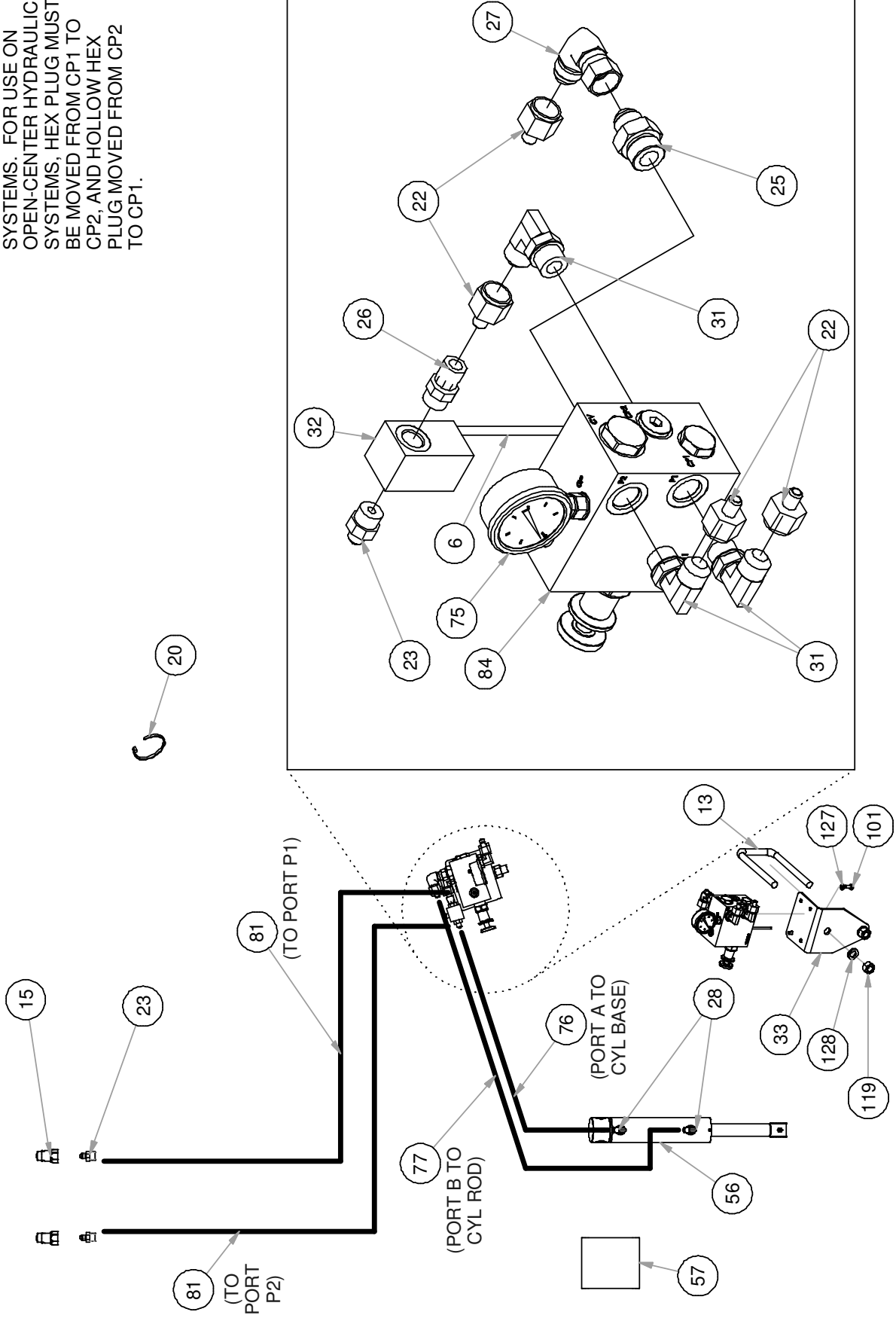

SECTION 2 - ASSEMBLY

ITEM	PN	DESCRIPTION	ITEM	PN	DESCRIPTION	ITEM	PN	DESCRIPTION
1	7L2150	STL 1/2 X 7-1/2"OD X 2-9/16"ID	52	8K1900	SEAL GBGI V WALKING TANDEM 01-	103	8X0044	BOLT 7/16-14NC X 3-1/2"GR5 ZDI
2	7P8530	ROUND CR 2 1/2"-22 1/4" 07-	53	8K1920	RETAINING RING 2-7/8" INV 00-	104	8X0072	BOLT 1/2-13NC X 3-3/4" GR5 YZ
3	8A1004	CLAMP HOSE 5" #72	54	8K3002	GANG WRENCH	105	8X0110	BOLT 3/4-10NC X 1-1/4" GR5 YZ
4	8A1155	U-BOLT 3/8 X 6-1/16 X 5" SQ	55	8K5200	WASHER GANG BOLT 2.030"ID	106	8X0111	BOLT 3/4-10NC X 2-1/2" GR5 YZ
5	8A1156	U-BOLT 3/8 X 4-1/16 X 5" SQ	56	8K6313	HYD CYL 2.25 X 6" 1.25"ROD	107	8X0113	BOLT 3/4-10NC X 5" GR5 YZ
6	8A1954	TUBING GAGE LINE 1/4" OD	57	8K6413	SEAL KIT 2.25X6" CTD 14-	108	8X0121	BOLT 3/4-10NC X 6-1/2" GR5 YZ
7	8A4048	NYLON TIE .18 X 11"	58	8K7042	12.5L X 15 LRF ON 15X10X8 WHL	109	8X0133	BOLT 7/8-9NC X 3" GR5 ZDI
8	8A4050	NYLON TIE .30 X 8-7/8"	59	8K7123	WHT WHEEL BOLT 5/8-18UNF 97-	110	8X0139	BOLT 1-8NC X 3" GR5 ZDI
9	8A4052	NYLON TIE .30 X 15.25"	60	8K8000	STL 7K2045 3/8X3.5 PNTDLGHT	111	8X0140	BOLT 1-8NCX7" W/1.5"THDGR5 YZ
10	8CC8018	PARALLEL LINK W/MNT HOLDS	61	8K8010	TUBE LGHT BRCKT 1.55055.5"00-	112	8X0146	BOLT 1-8NCX8.5" W/1.5"THD GR5ZDI
11	8CC8020	D/C CHSL PARALLEL LINK	62	8K8020	MOUNTING BRCKT LIGHT 00-	113	8X0202	NUT 3/8"-16NC NY-LOCK GR2 YZ
12	8CC8036	WASHER 2.5X4 X 1.281ID	63	8K8030A	MODULE AG ENHNCW/BRAKE6PIN08-	114	8X0203	NUT 3/8"-16NC SERFLANG GR2 YZ
13	8D0340	U-BOLT 3/4 X 4-1/16 X 7-3/4" SQ	64	8K8067	DUST CAP FOR 7PIN CONNECT00-	115	8X0211	NUT 5/16"-18NC SERFLANG GR2 YZ
14	8D2470	SAFETY CHAIN 7/16" X 5'	65	8K8070B	MAIN HRNSS 7PNLNG W/BRAKE 09-	116	8X0223	NUT 1/4"-20NC SERFLANG GR2 YZ
15	8D3212	MALE TIP 3/4"-16 ORB ISO	66	8K8075A	EXT HRNSS NONDRAWBR DTSCH 07-	117	8X0234	NUT 7/16"-14NC NY-LOCK GR2 ZDI
16	8D8490	PIONEERISO TIP HLDR BNT	67	8K8095B	LIGHT LED AMBER 2WR DTSCH 12-	118	8X0242	NUT 1/2"-13NC NY-LOCK GR2 YZ
17	8D8500	HYD HOSE HOLDER PNTD BLK 91-	68	8K8095B	LIGHT LED RED 3 WIRE DTSCH 12-	119	8X0260	NUT 3/4"-10NC HEX GR2 YZ
18	8D8522	JACK 5000# TOP CRANK 15"LIFT	69	8K8105A	EXT HRNSS 282WIRE DTSCH 07-	120	8X0261	NUT 3/4"-10NC NY-LOCK GR2 YZ
19	8D9108	ROLL PIN 1/4 X 2"YLW ZNC	70	8K8200	BRCKT SMV ATTC 4-8 FRAME98-	121	8X0270	NUT 7/8"-9NC CNTRLOCK GR2 YZ
20	8G3282	NYLON TIE .187 X 7-1/2" RED	71	8K9106	PIN 1-1/4 X 4-3/8" HARDENED	122	8X0280	NUT 1"-8NC HEX GR2 YZ
21	8G3285	NYLON TIE .187 X 7-1/2" GREEN	72	8L0246	BUSHING 2.8750DX2.5ID X3"	123	8X0284	NUT 1-1/4"-7NC HEX GR2 YZ
22	8J5200	#10 JIC(F) X #6 JIC(M)HEX BUSH	73	8L0288	U-BOLT 5/16 X 1-1/2 X 2-1/2"SQ	124	8X0285	NUT 1-1/2"-6NC HEX GR2 YZ
23	8J5210	3/4"-16 ORB X #6 JIC(M) STR	74	8L0320	PLATE 2PT CASTER WEAR	125	8X0286	NUT 1-1/2"-6NC JAM GR2 YZ
24	8J5520	3/4"-16 ORB X #10 JIC(M) STR	75	8N0250	HYD PRESSURE GAGE 2.5"	126	8X0292	NUT 2"-4.5 HVY HEXSLOT GR2 PLN
25	8J5550	1-1/16" - 12ORB#10JIC(M)STR	76	8N3035	3/8X 35" HYD HOSE #6FJX3000PSI	127	8X0300	LOOKWASHER 5/16" YLW ZNC
26	8J5620	3/4"-16 ORB X #6 JIC(F-SW) STR	77	8N3048	3/8 X 48" HYD HOSE #6FJX3000 PSI	128	8X0306	LOOKWASHER 3/4" YLW ZNC
27	8J5710	#10 JIC(F-SW)X#10 JIC(M)ADP	78	8N3060	3/8 X 60" HYD HOSE #6FJX3000PSI	129	8X0307	LOOKWASHER 7/8" YLW ZNC
28	8J6000	9/16"-18 ORB X #6 JIC(M)90"ADP	79	8N3108	3/8" X 108" HYD HOSE #6FJX3000PSI	130	8X0309	LOOKWASHER 1" YLW ZNC
29	8J6010	3/4"-16 ORB X #6 JIC(M)90"ADP	80	8N3252	3/8 X 252" HYD HOSE #6FJX3000PSI	131	8X0311	LOOKWASHER 1-1/4" YLW ZNC
30	8J6020	3/4"-16 ORB X #10 JIC(M)90"ADP	81	8N3390	3/8" X 390" HYD HOSE #6FJX3000PSI	132	8X0318	WASHER 3/4"(13/16"ID)FLAT YZ
31	8J6030	7/8"-14 ORB X #10 JIC(M)90"ADP	82	8N4120	1/2" X 120" HYD HOSE #10FJX3000PSI	133	8X0320	WASHER 3/8" (7/16" ID)FLAT ZDI
32	8J7040	THERMAL RELIEF MANIFLD 4000PSI	83	8N6354	3/4" X 354" HYD HOSE #10FJX3000PSI	134	8X0402	HAIR PIN CLIP 1/8 X 2-9/16"
33	8K0050	MNT BRKT ADJ DP MANFLD	84	8N7000	ADJ DOWN PRESSURE MANIFLD	135	8X0405	SNAPPER PIN 1/4 X 1.75"
34	8K1105S	HUB&AXLE ASSY HD812 (2"RCVR)	85	8S1120	SIGN SLOW MOVING VEHICLE(SMV)	136	8X0440	CLEVIS PIN 5/8 X 3-7/8" ZDI
35	8K1152	LIFT ARM 18.5 - 32.5 REAR CNTR	86	8S1124	MOUNTING SOCKET SMV SIGN ZDI	137	8X1120	CRG 3/8-16NC X 2" GR2 ZN
36	8K1410	HITCH NRRW DSK	87	8S1126	MNT SPADE W/HRDWR SMV SIGN	282	8Z0075	TRANSPORT LOCK DECAL
37	8K1415	CNTR FRAME NRRW DSK-LEFT	88	8S2990	HYD HOSE CLAMP-LARGE-NYLON	253	8Z0087	DECAL "WARNING"PINCH POINT03-
38	8K1417	CNTR FRAME NRRW DSK-RGHT	89	8S3095	CAPLUG FITS ISO HYD COUPLR 08-	254	8Z0100	MADE IN THE USA DECAL
39	8K1425	TRANSPREST CRSTUBE NRRW DSK	90	8T1006	PLUNGER PIN W/HS RAM 98-	255	8Z0202	3.5" SUMMERS DECAL
40	8K1430	SPLICE TUBE FRONT NRRW DSK	91	8T1010	POPPET	256	8Z0204	5.5" SUMMERS DECAL
41	8K1435	A-FRAME NRRW DSK	92	8T1045	HYD CYL 4.5 X 10" REPHASE 96-	257	8Z0276	GENERAL MACHINE CAUTION DECAL
42	8K1449	BOLT-ON LINK ARM PIVOT-R	93	8T1050	HYD CYL 5.0 X 10" REPHASE 96-	258	8Z0340	REPHASING CYLINDERS DECAL
43	8K1451	BOLT-ON LINK ARM PIVOT-L	94	8T1055	HYD CYL 5.5 X 10" REPHASE 96-	259	8Z0342	INSTALL CYL LOCKS DECAL
44	8K1452	CASTR CYLATTCH SIDEPLATE DSK	95	8T1060	HYD CYL 6 X 10 W/ STRK CNTRL 96-	260	8Z0344	DECAL WING DANGER
45	8K1470	CASTR CYL ATTCH BOLT-IN	96	8T3620	PIN 1-1/2 X 12-1/2" HRDND&ZINC	261	8Z0346	ELECTROCUTION-TILLAGE EQUIP. DECAL
46	8K1475	CASTER ARM DISK -L	97	8T4132	WLKNG TNDM 7.5"C-C 2" ID 98-	262	8Z0350	GANG BEARING GREASE DECAL
47	8K1477	CASTER ARM DISK -R	98	8T4350	TRNS LCK W/UHMW10.5(12.4RD)	263	8Z0352	CASTER WHEELTORQUE DECAL
48	8K1500	DISK CASTER MNT	99	8X0000	BOLT 1/4-20X3/4" FLTTHD GR5 YZ	264	8Z0800	REFLECTOR AMBER ADHSVBC98-
49	8K1640	PIN 1-1/2 X 10-5/8" HITCH 84-	100	8X0015	BOLT 3/8-16NC X 3-3/4" GR5 ZDI	265	8Z0805	REFLECTR REDORANGE ADHSVBK99-
50	8K1660	PIN 1-1/2 X 15-1/2" HARDEND	101	8X0021	BOLT 5/16-18NC X 3/4" GR5 ZDI	266	8Z0810	REFLECTOR RED ADHSV-BACK 98-
51	8K1755	EYEBOLT 1.5DIA X 1.26"EYE X 14"YZ	102	8X0021A	BOLT 5/16-18NC X 1" GR5 ZDI	154	8Z1000	MANUAL-PAK 3DIA X 11.75" 09-

SECTION 2 - ASSEMBLY

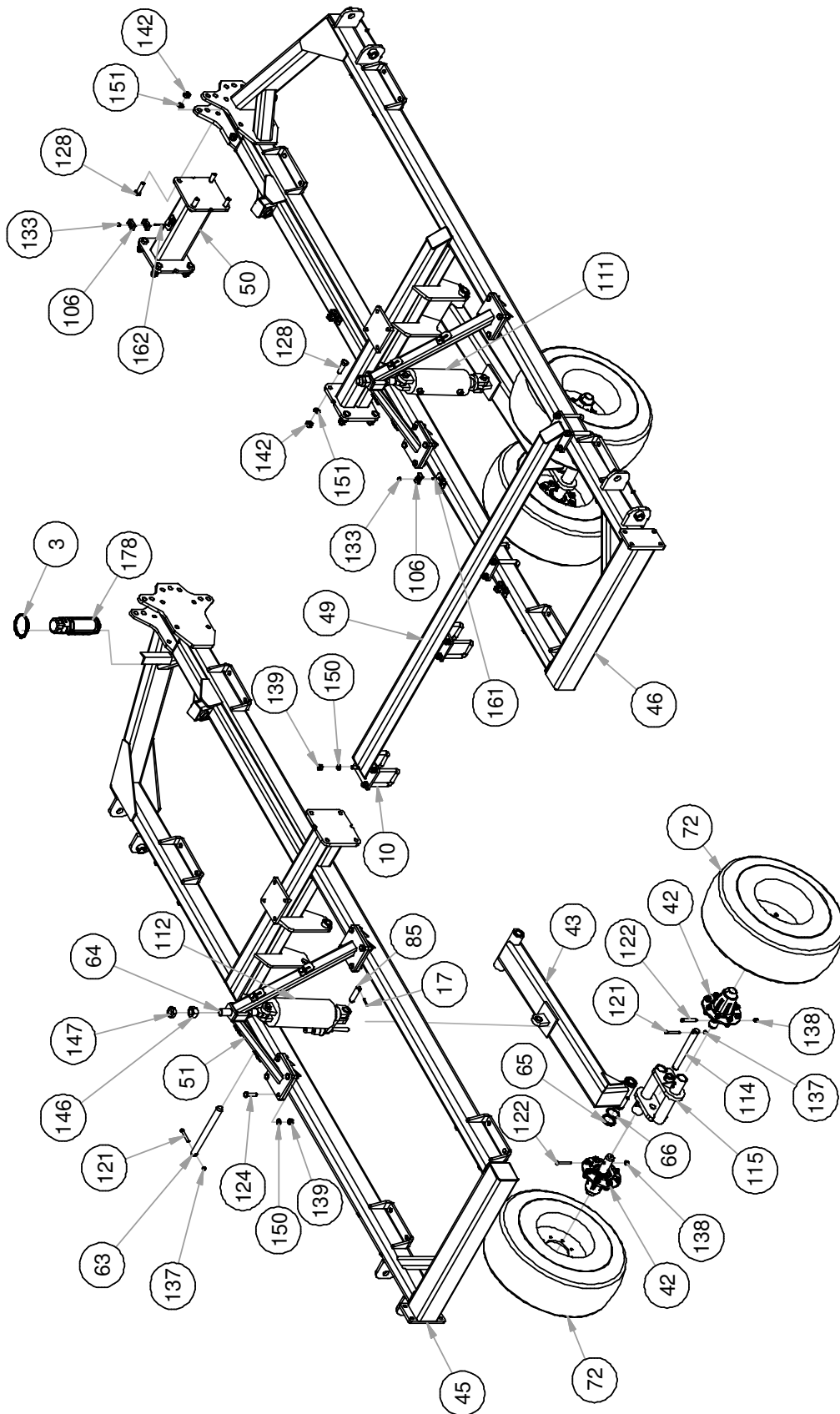

SECTION 2 - ASSEMBLY

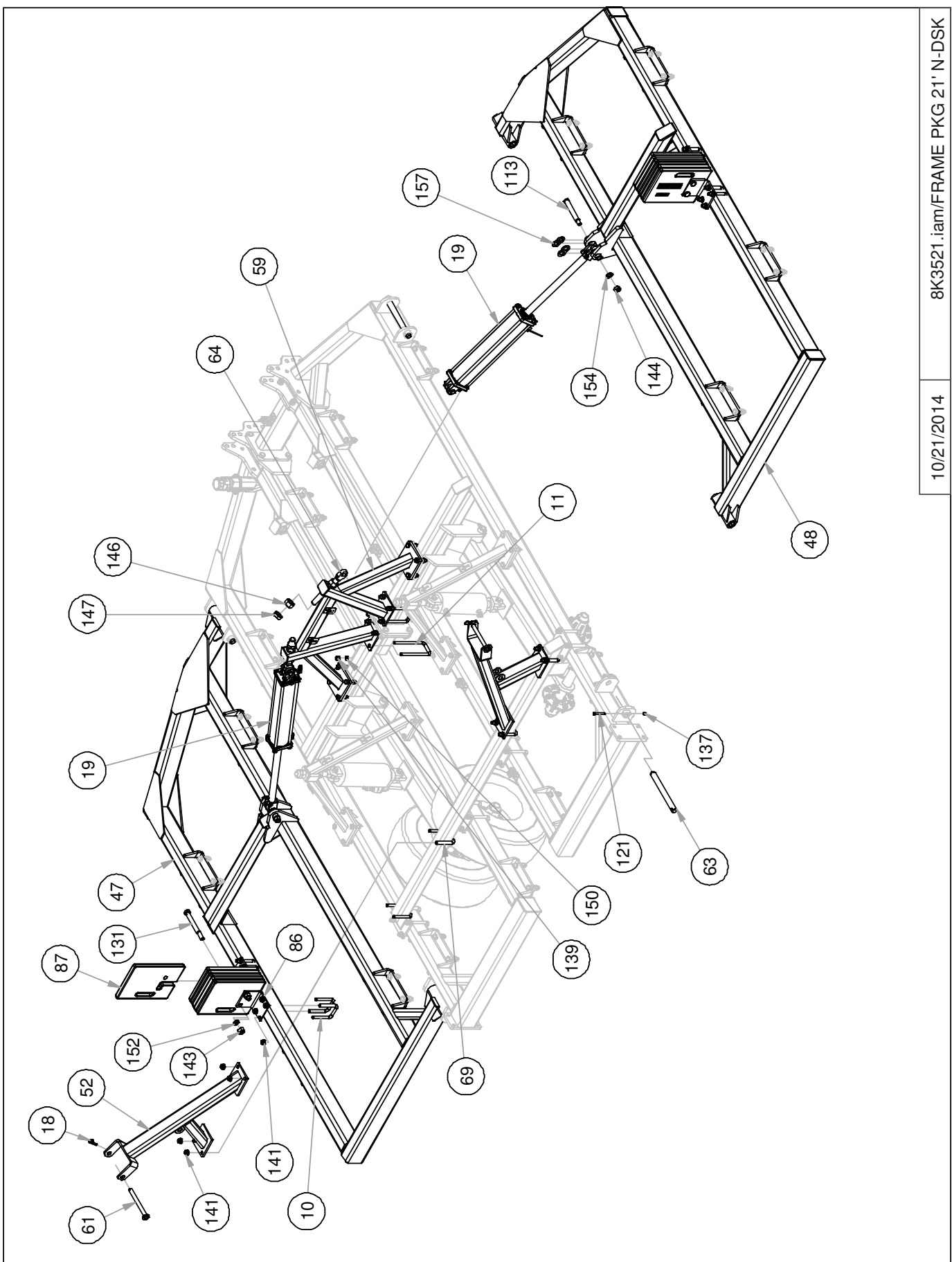

8K3521.iam/FRAME PKG 21' N-DSK

10/21/2014

SECTION 2 - ASSEMBLY

8K3521.iam/FRAME/PKG 21' N-DSK

10/21/2014

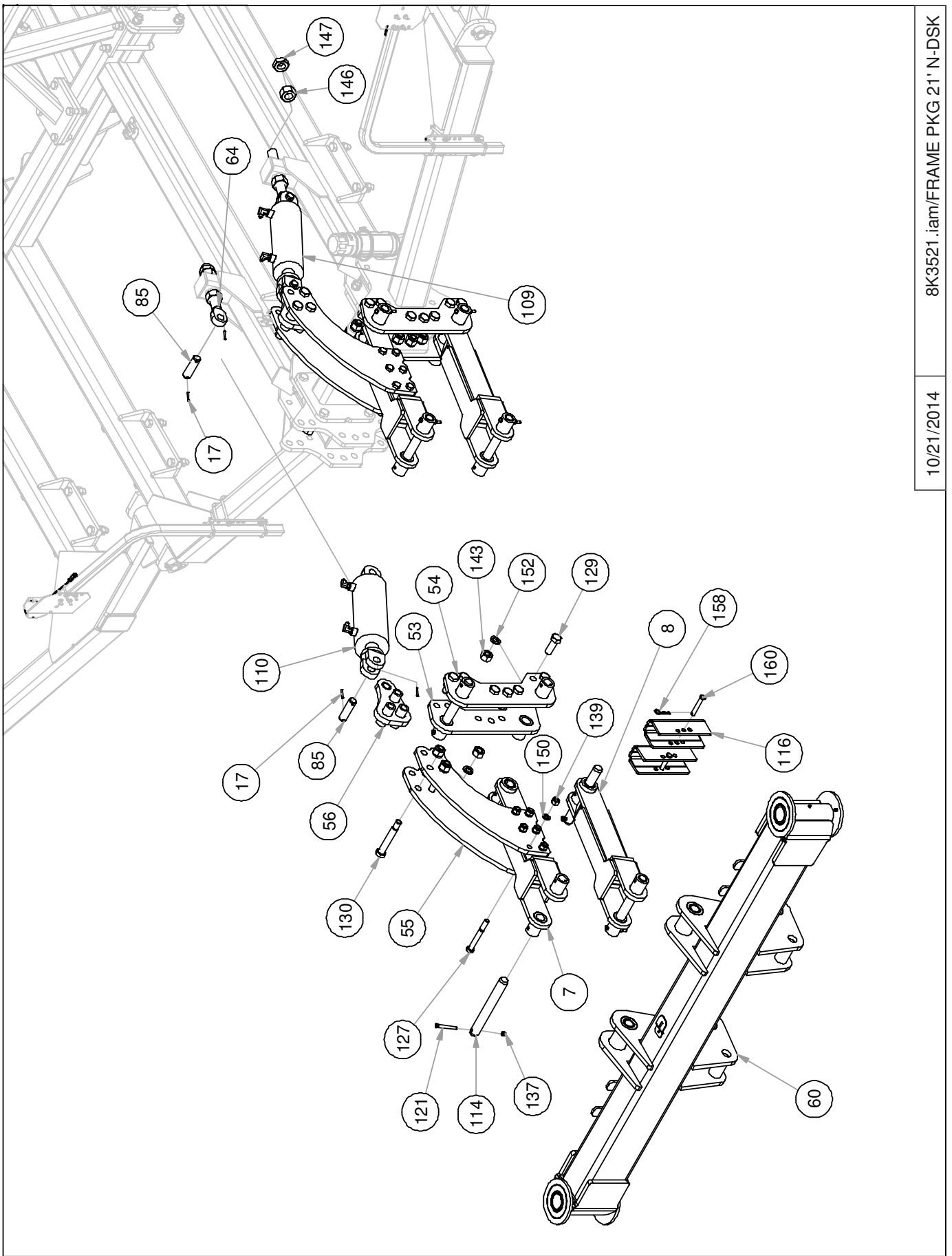

SECTION 2 - ASSEMBLY

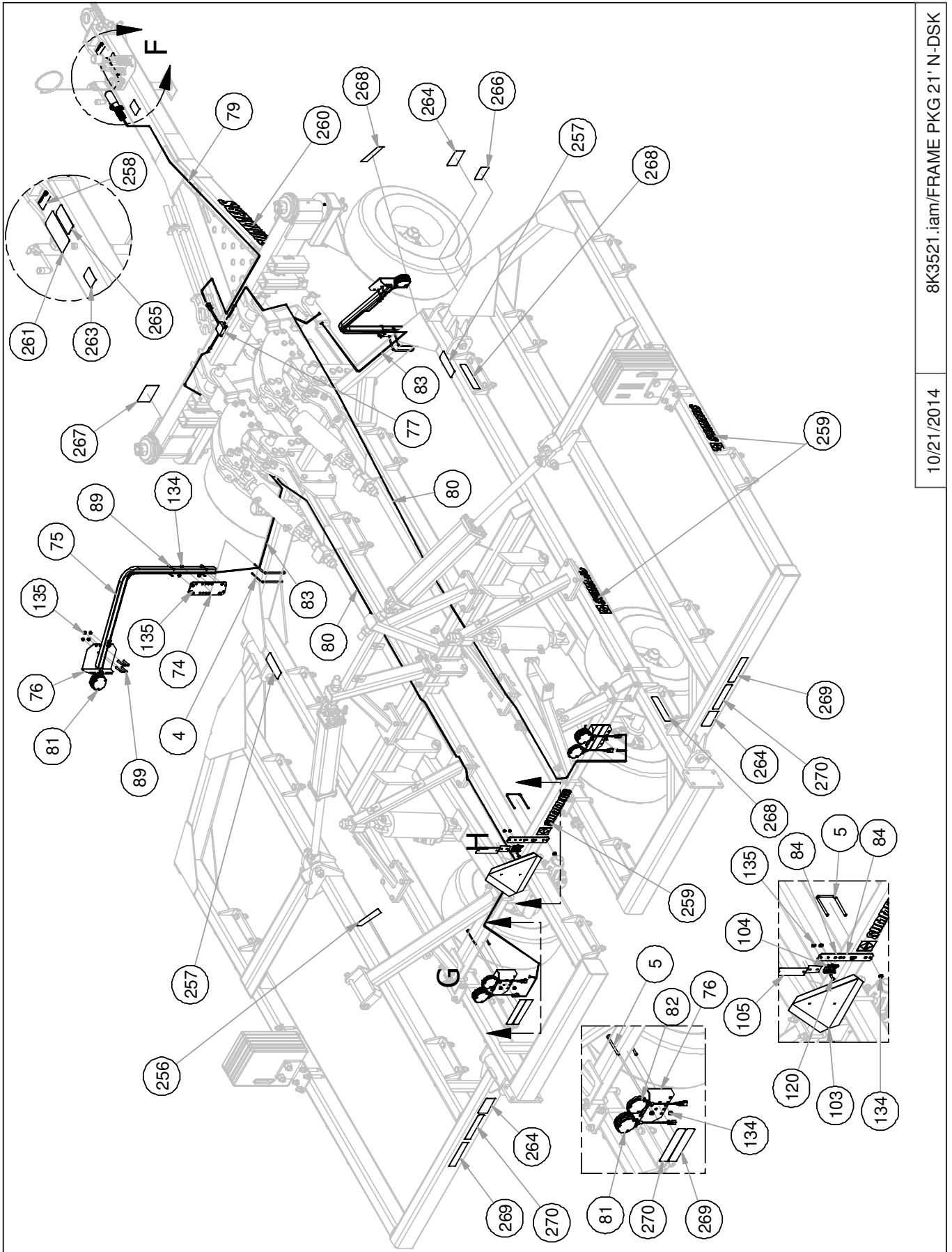

8K3521 .iam/FRAME PKG 21' N-DSK

10/21/2014

DEPTH CONTROL HYDRAULICS

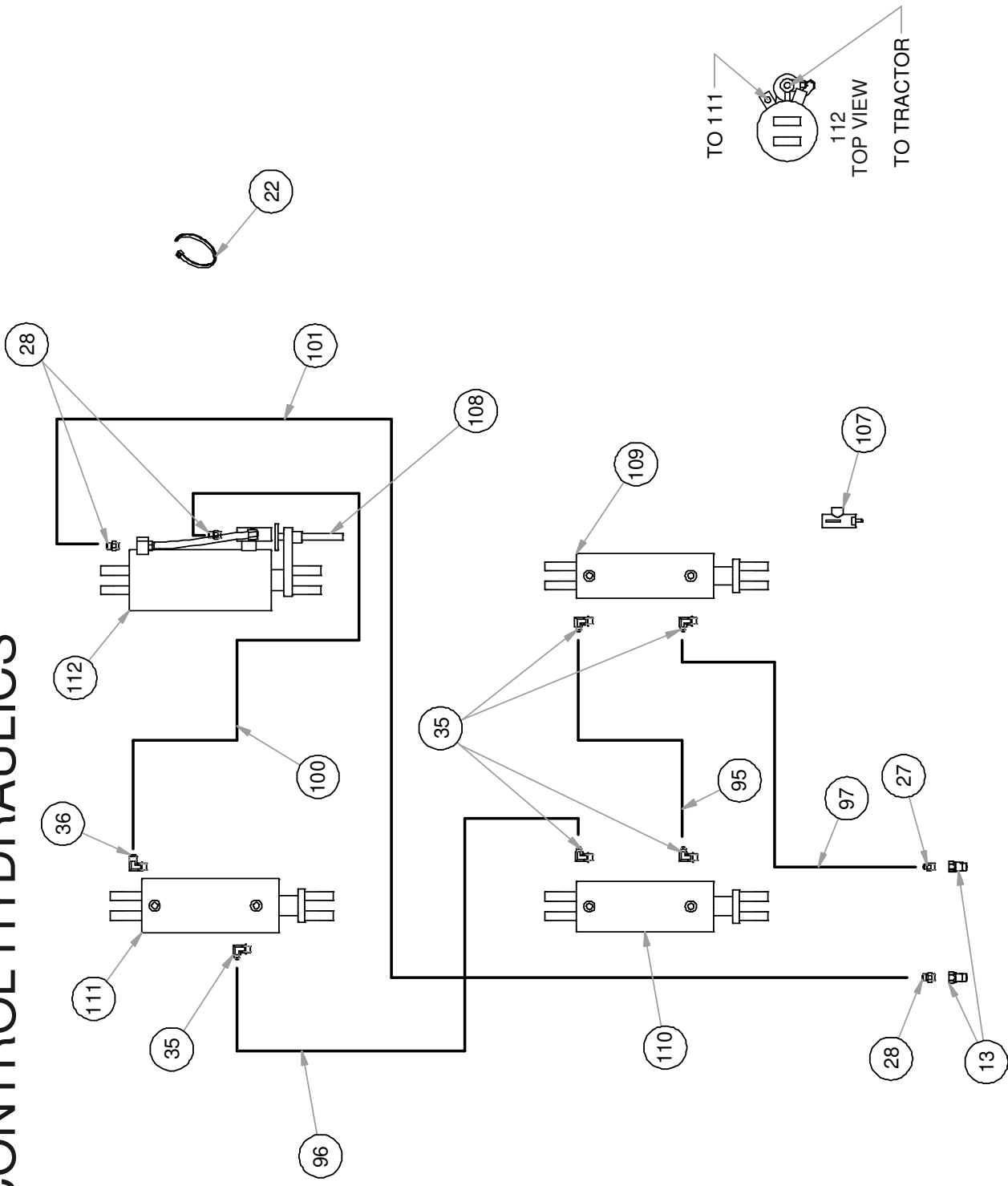

10/21/2014

8T1060.iam/FRAME PKG 21' N-DSK

REAR COULTER HYDRAULICS

NOTE:
 BLOCK IS CONFIGURED FOR
 USE ON TRACTORS WITH
 CLOSED-CENTER HYDRAULIC
 SYSTEMS. FOR USE ON
 OPEN-CENTER HYDRAULIC
 SYSTEMS, HEX PLUG MUST
 BE MOVED FROM CP1 TO
 CP2, AND HOLLOW HEX
 PLUG MOVED FROM CP2
 TO CP1.

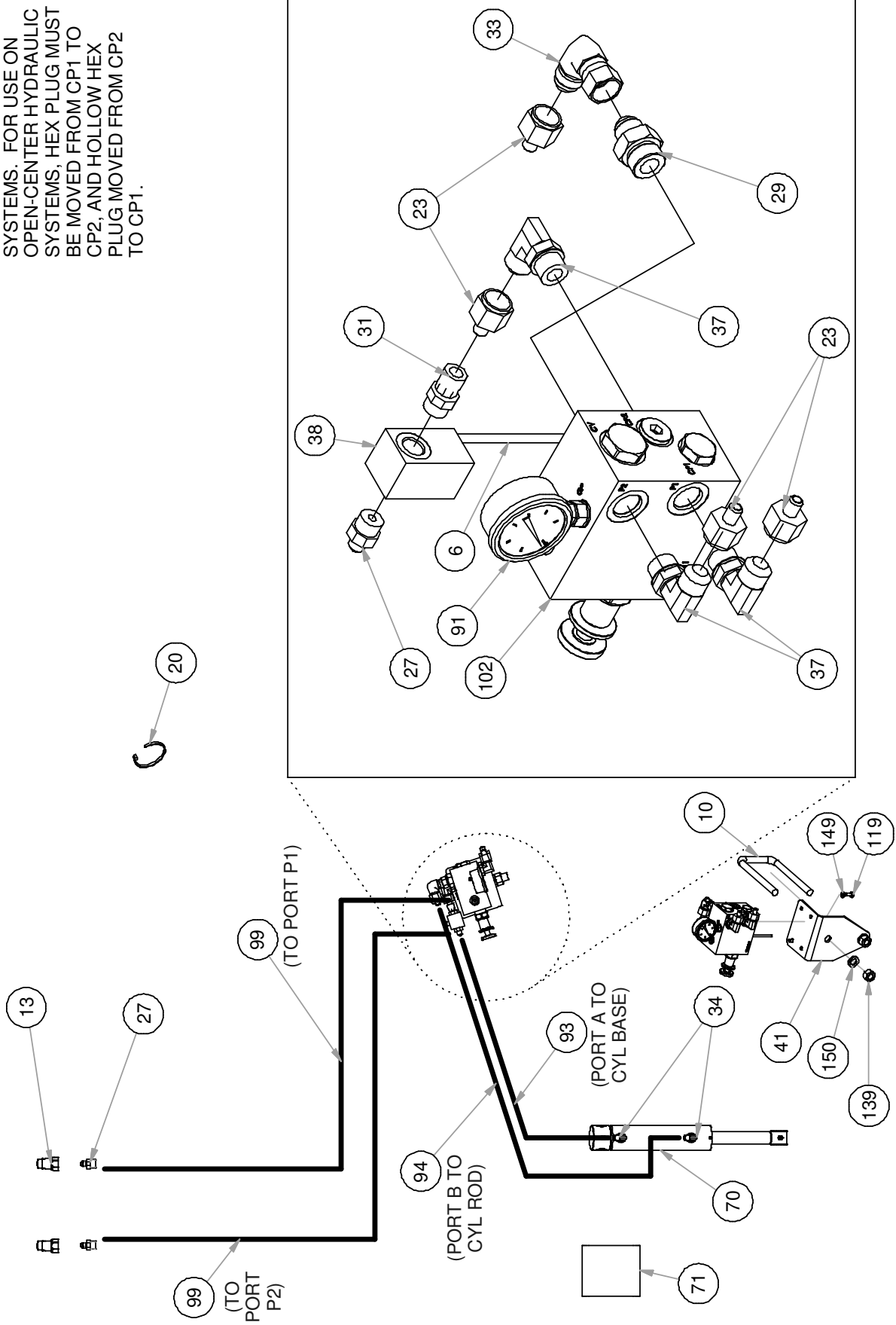

SECTION 2 - ASSEMBLY

8K3521 Parts List

ITEM	PN	QTY	DESCRIPTION	ITEM	PN	QTY	DESCRIPTION	ITEM	PN	QTY	DESCRIPTION	ITEM	PN	QTY	DESCRIPTION	ITEM	PN	QTY	DESCRIPTION
1	7L2150	2	STL 1/2 X 7-1/2" OD X 2-9/16" ID	46	8K1417	1	CNTR FRAME NRRW DSK-RGHT	91	8N0250	1	HYD PRESSURE GAGE 2.5"	136	8X0223	2	NUT 1/4"-20NC SER FLANG GR2ZDI				
2	7P6530	2	ROUND CR 2 1/2-22 1/4" 07-	47	8K1421	1	WING FRAME NRRW DSK-LEFT 21"	92	8N3028	2	3/8 X 28" HYD HOSE #6FJX3000PSI	137	8X0234	18	NUT 7/16"-14NC NY-LOCK GR2 ZDI				
3	8A1004	1	CLAMP HOSE 5" #72	48	8K1423	1	WING FRAME NRRW DSK-RGHT 21"	93	8N3035	2	3/8 X 35" HYD HOSE #6FJX3000PSI	138	8X0242	6	NUT 1/2"-13NC NY-LOCK GR2 ZDI				
4	8A1155	3	U-BOLT 3/8 X 6-1/16 X 5" SQ	49	8K1425	1	TRANSFRST CRSTUBE NRRW DSK	94	8N3048	3	3/8 X 48" HYD HOSE #6FJX3000PSI	139	8X0260	62	NUT 3/4"-10NC HEX GR2 ZDI				
5	8A1156	3	U-BOLT 3/8 X 4-1/16 X 5" SQ	50	8K1430	1	SPLICE TUBE FRONT NRRW DSK	95	8N3080	1	3/8 X 60" HYD HOSE #6FJX3000PSI	140	8X0261	2	NUT NY-LOCK 3/4"-10NC GR2 ZDI				
6	8A1954	3	TUBING GAGE LINE 1/4" OD	51	8K1435	2	A-FRAME NRRW DSK	96	8N3180	1	3/8 X 180" HYD HOSE #6FJX3000PSI	141	8X0266	8	NUT 3/4"-10NC SER FLANG GR2 YZ				
7	8CC6018	2	PARALLEL LINK W/ MNT HOLDS	52	8K1440	2	WINGLOCK NRRW DSK	97	8N3252	1	3/8 X 252" HYD HOSE #6FJX3000PSI	142	8X0270	72	NUT 7/8"-8NC CNTRLOCK GR2 YZ				
8	8CC6035	2	WASHER 2.5X4 X 1.281ID	53	8K1449	2	BOLT-ON LINK ARM PIVOT-R	98	8N3312	2	3/8 X 312" HYD HOSE #6FJX3000PSI	143	8X0280	35	NUT HEX 1"-8NC GR2 ZDI				
9	8D03340	17	U-BOLT 3/4 X 4-1/16 X 7-3/4" SQ	54	8K1451	2	BOLT-ON LINK ARM PIVOT-L	99	8N3390	2	3/8 X 390" HYD HOSE #6FJX3000PSI	144	8X0282	2	NUT 1"-14NF TOPLOCK GR2 ZDI				
10	8D03350	4	U-BOLT 3/4 X 4-1/16 X 10" SQ	55	8K1452	4	CASTR CYL ATTCH SIDEPLATE DSK	100	8N4120	1	1/2 X 120" HYD HOSE #10FJX3000PSI	145	8X0284	2	NUT HEX 1.25"-7NC GR2 ZDI				
11	8D03350	4	U-BOLT 3/4 X 4-1/16 X 10" SQ	56	8K1470	2	CASTR CYL ATTCH BOLT-IN	101	8N6354	1	3/4 X 354" HYD HOSE #10FJX3000PSI	146	8X0285	12	NUT 1-1/2"-6NC HEX GR2 YZ				
12	8D2470	1	SAFETY CHAIN 7/16" X 5'	57	8K1475	1	CASTER ARM DISK-L	102	8N7000	1	ADJ.DOWN PRESSURE MANIFLD	147	8X0286	6	NUT 1-1/2"-6NC JAM GR2 ZDI				
13	8D3212	6	MALE TIP 3/4"-16 ORB PIONEER	58	8K1477	1	CASTER ARM DISK-R	103	8S1120	1	SIGN SLOW MOVING VEHICLE(SMV)	148	8X0292	2	NUT 2"-4.5 HVY HEXSLT GR2 PLN				
14	8D8490	1	PIONEERISO TIP HDR BNT	59	8K1485	1	WING LIFT CYL ATTCH NRRW DSK	104	8S1124	1	MOUNTING SOCKET SMV SIGN ZDI	149	8X0300	2	LOCKWASHER 5/16"-YLVW ZNC				
15	8D8500	1	HYD HOSE HOLDER PNTD BLK 91-	60	8K1500	1	DISK CASTER MNT	105	8S1126	1	MNT SPADE W/HRDWR SMV SIGN	150	8X0306	62	LOCKWASHER 3/4"-YLVW ZNC				
16	8D8522	1	JACK 500#R TOP CRANK 15" LIFT	61	8K1615	2	PIN 3/4X10-1/2" SAFETYLOCK	106	8S2990	38	HYD HOSE CLAMP-LARGE-NYLON	151	8X0307	72	LOCKWASHER 7/8"-YLVW ZNC				
17	8D9108	20	ROLL PIN 1/4 X 2" YLVW ZNC	62	8K1640	2	PIN 1-1/2 X 10-5/8" HITCH 84-	107	8T1006	1	POPET	152	8X0309	35	LOCKWASHER 1" YLVW ZNC				
18	8D9110	2	HAIR PIN CLIP LARGE(1"CYL PIN)	63	8K1660	6	PIN 1-1/2 X 15-1/2" HARDEN	108	8T1010	1	POPET	153	8X0311	2	LOCKWASHER 1-1/4" YLVW ZNC				
19	8D9524	2	HYD CYL 5 X 24"	64	8K1755	6	EYEBOLT 1.5DIA X 1.28" EYE X 14" YZ	109	8T1045	1	HYD CYL 4.5 X 10" REPHASE 96-	154	8X0316	2	WASHER SAE FLAT 1" ZDI				
20	8G2282	6	NYLON TIE .187 X 7-1/2" YELLOW	65	8K1900	4	SEAL GBGI V WALKING TANDEM 01-	110	8T1050	1	HYD CYL 5.0 X 10" REPHASE 96-	155	8X0318	1	WASHER 3/4"(13/16"ID)FLAT ZDI				
21	8G2282	6	NYLON TIE .187 X 7-1/2" GREEN	66	8K1920	4	RETAINING RING 2-7/8" INV 00-	111	8T1055	1	HYD CYL 5.5 X 10" REPHASE 96-	156	8X0320	4	WASHER 3/8" (7/16" ID)FLAT ZDI				
22	8G2285	6	NYLON TIE .187 X 7-1/2" GREEN	67	8K3002	2	GANG WRENCH	112	8T1060	1	HYD CYL 6 X 10 W/ STRK CNTRL 96-	157	8X0327	8	WASHER SAE FLAT 1-1/4" ZDI				
23	8J5200	8	#10 JIC(F) X #6 JIC(M) HEX BUSH	68	8K5200	2	WASHER GANG BOLT 2.030" ID	113	8T3300	2	PIVOT BOLT CHSLTRP/WNGFLT YZ	158	8X0402	4	HAIR PIN CLIP 1/8 X 2.9/16"				
24	8J5298	2	TEE #6 SWIMLNUSTRUM(HF+FF-SW)	69	8K5515	4	U-BOLT 3/4 X 4 X 6" SQ	114	8T3620	10	PIN 1-1/2 X 12-1/2" HRDND&ZNC	159	8X0405	1	SNAPPER PIN 1/4 X 1.75"				
25	8J5300	2	#6 JIC (MALE) 3X TEE	70	8K6313	1	HYD CYL 2.25 X 6" 1.25" ROD	115	8T4132	2	WLKNG TNDM 7.5"C-2" ID 98-	160	8X0440	4	CLEVIS PIN 3/8 X 3-7/8" ZDI				
26	8J5500	1	9/16"-18 ORB X #6 JIC(M) STR	71	8K6413	1	SEAL KIT 2.25X6" CTD 14-	116	8T4350	4	TRNS LOCK W/UMHW10.5"(2.4RD)	161	8X1120	12	CRG 3/8-16NC X 2" GR2 ZN				
27	8J5510	7	3/4"-16 ORB X #6 JIC(M) STR	72	8K7042	6	12.5L X 15 LRF ON 15X10X8 WHL	117	8X0000	2	BOLT 1/4-20X3/4" F/ULL THDRGRS ZDI	162	8X1140	6	CRG 3/8-16NC X 4" GR2 ZN				
28	8J5520	3	3/4"-16 ORB X #10 JIC(M) STR	73	8K7123	1	NUT 5/8"-18UNF WHEEL BOLT 97-	118	8X0015	2	BOLT 3/8-16NC X 3-3/4" GR5 ZDI	163	8Z0075	2	TRANSPORT LOCK DECAL				
29	8J5550	1	1-1/16"-12ORBX#10JIC(M)STR	74	8K8000	2	STL 7K2045 3/8X3.5 PNTDLGHT	119	8X0021	2	BOLT 5/16-18NC X 3/4" GR5 ZDI	164	8Z0087	2	PINCH POINT DECAL				
30	8J5600	1	9/16"-18 ORB X #6 JIC(F-SW)STR	75	8K8010	2	TUBE LGHT BRCKT1.5S055.5"00-	120	8X0021A	2	BOLT 5/16-18NC X 1" GR5 ZDI	165	8Z0100	1	MADE IN THE USA DECAL				
31	8J5620	2	3/4"-16 ORB X #6 JIC(F-SW) STR	76	8K8020	4	MOUNTING BRCKT LIGHT 00-	121	8X0044	18	BOLT 7/16-14NC X 3-1/2" GR5 ZDI	166	8Z0202	5	3.5" SUMMERS DECAL				
32	8J5700	3	#6 JIC (F-SW) X #6 JIC (M) 90" ADP	77	8K8030A	1	MODULE AG	122	8X0072	6	BOLT 1/2-13NC X 3-3/4" GR5 ZDI	167	8Z0204	2	5.5" SUMMERS DECAL				
33	8J5710	1	#10 JIC (F-SW) X #10 JIC (M) 90" ADP	78	8K8067	1	ENHNCDW/BRKSPIN08-	123	8X0110	1	BOLT 3/4-10NC X 1-1/4" GR5 ZDI	168	8Z0276	1	GENERAL MACHINE CAUTION DECAL				
34	8J6000	2	9/16"-18 ORB X #6 JIC(M) 90" ADP	79	8K8070B	1	DUST CAP FOR 7PIN CONNECT00-	124	8X0111	16	BOLT 3/4-10NC X 2-1/2" GR5 ZDI	169	8Z0340	1	REPHASING CYLINDERS DECAL				
35	8J6010	5	3/4"-16 ORB X #6 JIC(M) 90" ADP	80	8K8075A	2	EXT HRNSS 7PNLNG W/BRAKE 09-	125	8X0113	2	BOLT 3/4-10NC X 3" GR5 ZDI	170	8Z0342	1	INSTALL CYL LOCKS DECAL				
36	8J6020	1	3/4"-16 ORB X #10 JIC(M)90"ADP	81	8K8090B	4	EXT HRNSS NONDRAMBR DTSCH 07-	126	8X0114	8	BOLT 3/4-10NC X 3" GR5 ZDI	171	8Z0344	4	WING DANGER DECAL				
37	8J6030	7	7/8"-14 ORB X #10 JIC(M)90"ADP	82	8K8095B	2	LIGHT LED AMBER 2WR DTSCH 12-	127	8X0121	12	BOLT 3/4-10NC X 6.5" GR5 ZDI	172	8Z0346	1	ELECTROCUSSION-TILLAGE EQUIP. DECAL				
38	8J7040	2	THERMAL RELIEF MANIFLD 4000PSI	83	8K8105A	2	LIGHT LED RED 3WR DTSCH 12-	128	8X0133	72	BOLT 7/8-9NC X 3" GR5 ZDI	173	8Z0350	2	GANG BEARING GREASE DECAL				
39	8J7216	2	#6JIC(M)X6JIC(F)1/16"RSTR GOLD	84	8K8200	1	BRCKT SMV ATTCH 4-8FRAME98-	129	8X0139	28	BOLT 1-8NC X 3" GR5 ZDI	174	8Z0352	1	CASTER WHEEL TORQUE DECAL				
40	8J7250	1	RELIEF VLV 2250PSI 9/16"-18ORB	85	8K9106	8	PIN 1-1/4 X 4-3/8" HARDENED	130	8X0140	6	BOLT 1-8NCX7" W/1.5"THD GR5ZDI	175	8Z0800	6	REFLECTOR - YELLOW - ADHESIVE BACKED				
41	8K0050	1	MNT BRKT ADJ DP MANFLD	86	8K9220	4	ANGLE 6X6X1/2-6.25"WGHTPKG99-	131	8X0145	4	BOLT 1-8NC X 10 1/2" GR5 YZ	176	8Z0805	4	REFLECTOR RED/ORANGE ADHESIVE BACKED				
42	8K1105S	6	HUB&AXLE ASSY HD812 (2"RCV/R)	87	8K9230	12	SUITSACE WGHT PNTD 1.25"-67#	132	8X0146	1	BOLT 1-8NCX8.5" W/1.5"THD GR5ZDI	177	8Z0810	4	REFLECTOR - RED - ADHESIVE BACKED				
43	8K1152	2	LIFT ARM 18.5" - 32.5" REAR CNTR	88	8K0246	4	BUSHING 2.875ODX2.5ID X3"	133	8X0202	18	NUT 3/8"-16NC NY-LOCK GR2 ZDI	178	8Z1000	1	MANUAL-PAK 3DIA X 11.75" 09-				
44	8K1410	1	CNTR FRAME NRRW DSK	89	8L0258	8	U-BOLT 5/16X1-1/2X2-1/2" SQ	134	8X0203	14	NUT 3/8"-16NC SER FLANG GR2ZDI								
45	8K1415	1	CNTR FRAME NRRW DSK-LEFT	90	8L0320	4	PLATE 2PT CASTER WEAR	135	8X0211	18	NUT 5/16"-18NC SERFLANG GR2ZDI								

SECTION 2 - ASSEMBLY

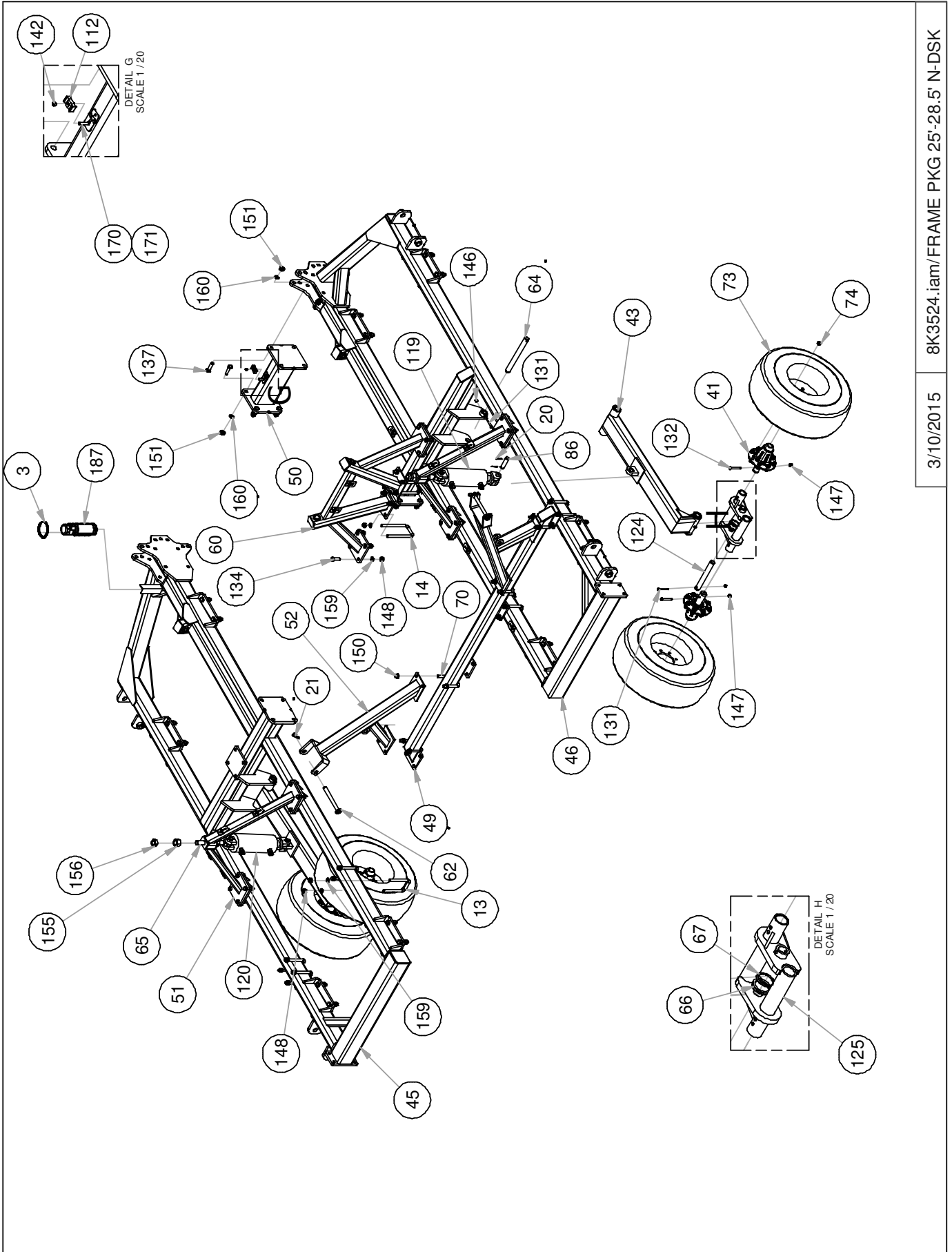

8K3524.iam/FRAME PKG 25'-28.5' N-DSK

3/10/2015

SECTION 2 - ASSEMBLY

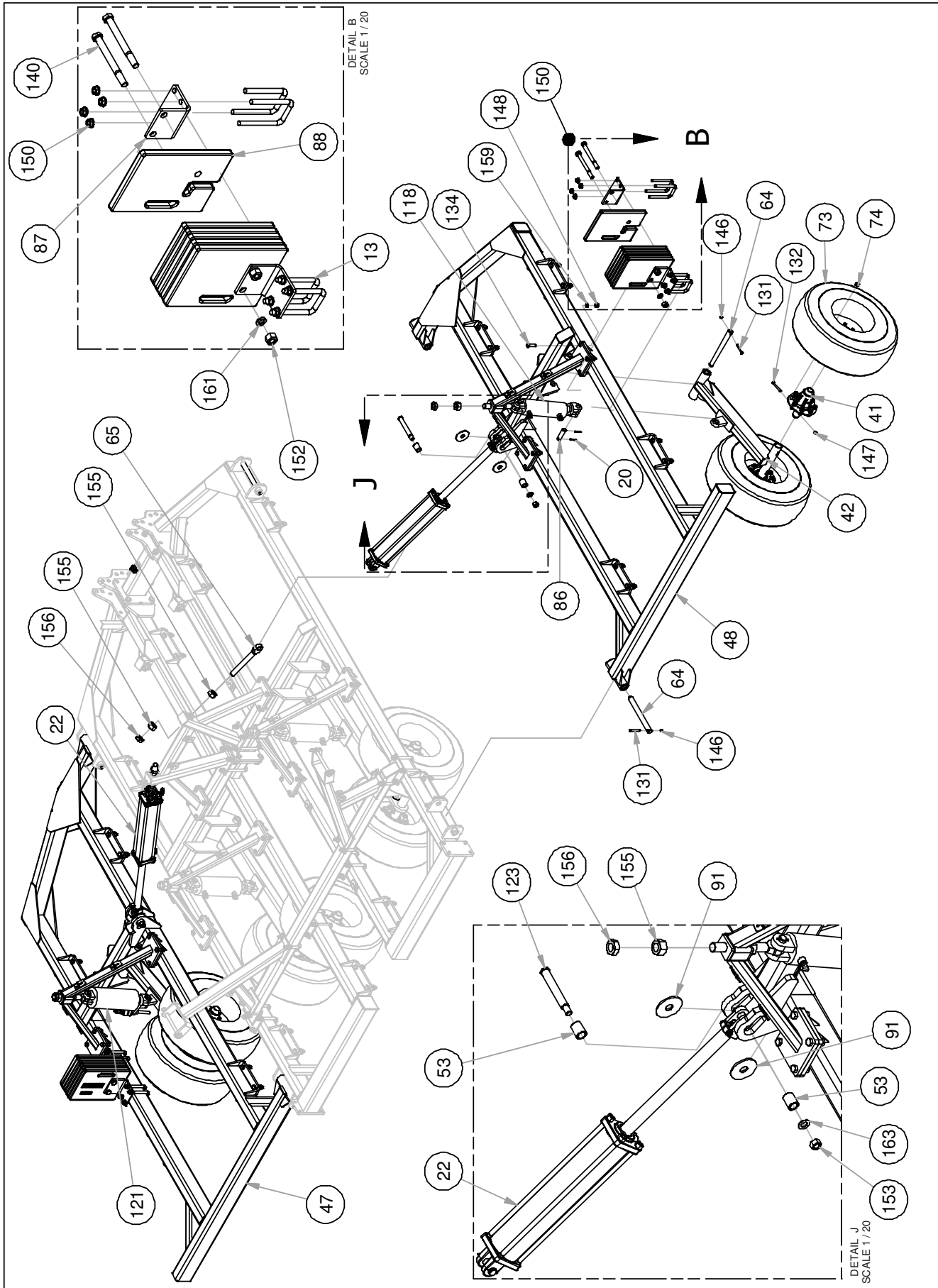

8K3524.iam/FRAME PKG 25'-28.5' N-DSK

3/10/2015

SECTION 2 - ASSEMBLY

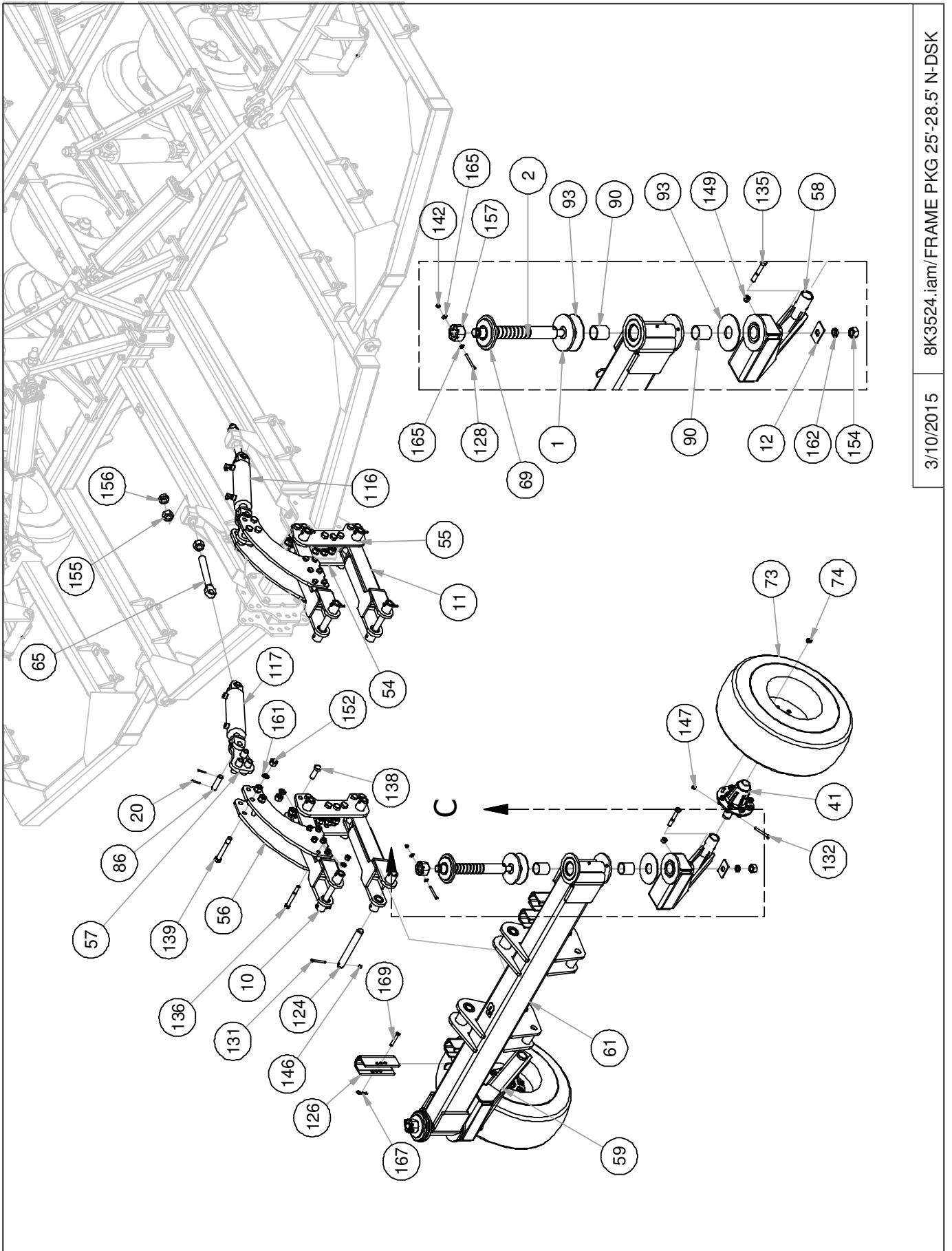

8K3524.iam/FRAME PKG 25'-28.5' N-DSK

3/10/2015

SECTION 2 - ASSEMBLY

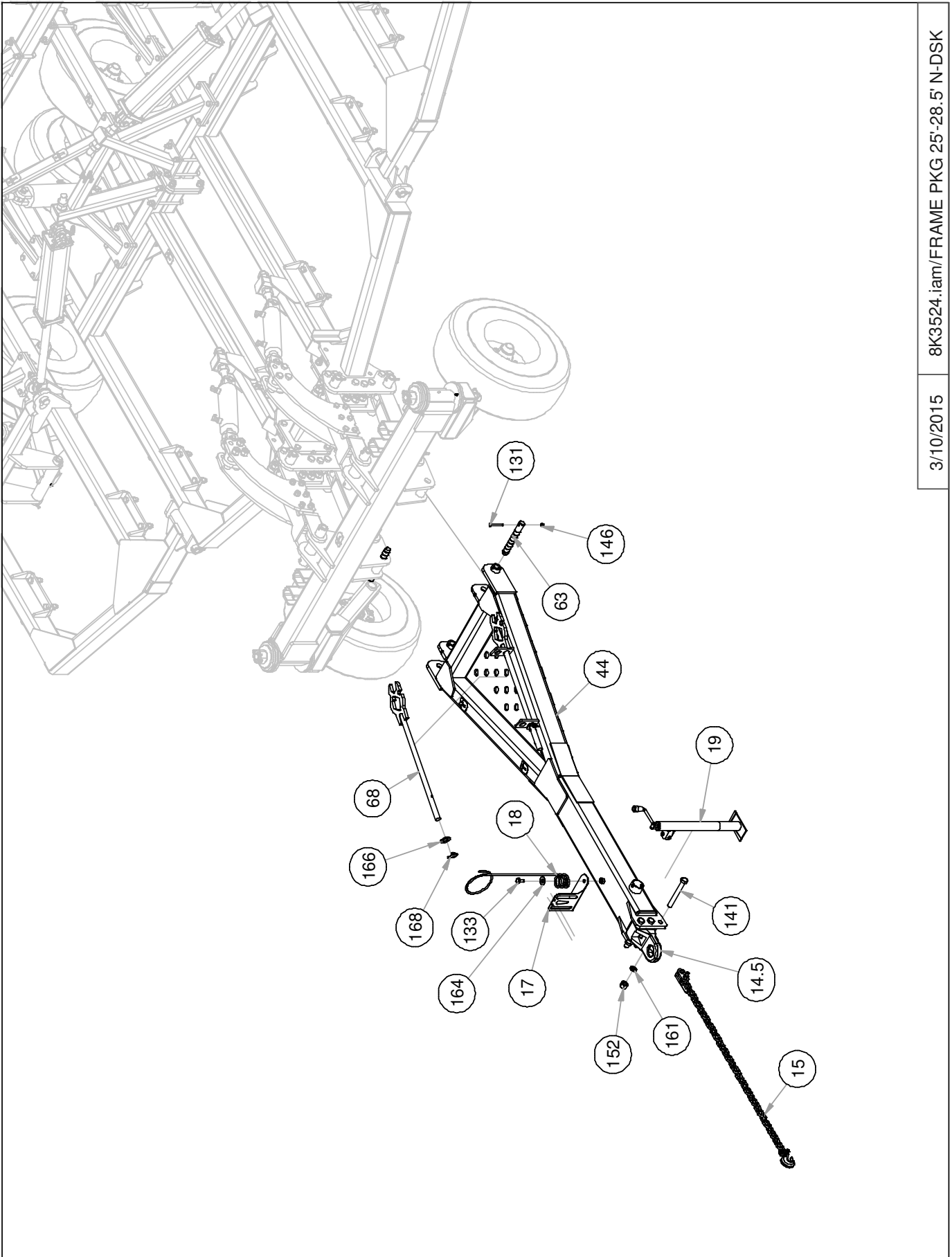

8K3524.iam/FRAME PKG 25'28.5' N-DSK

3/10/2015

SECTION 2 - ASSEMBLY

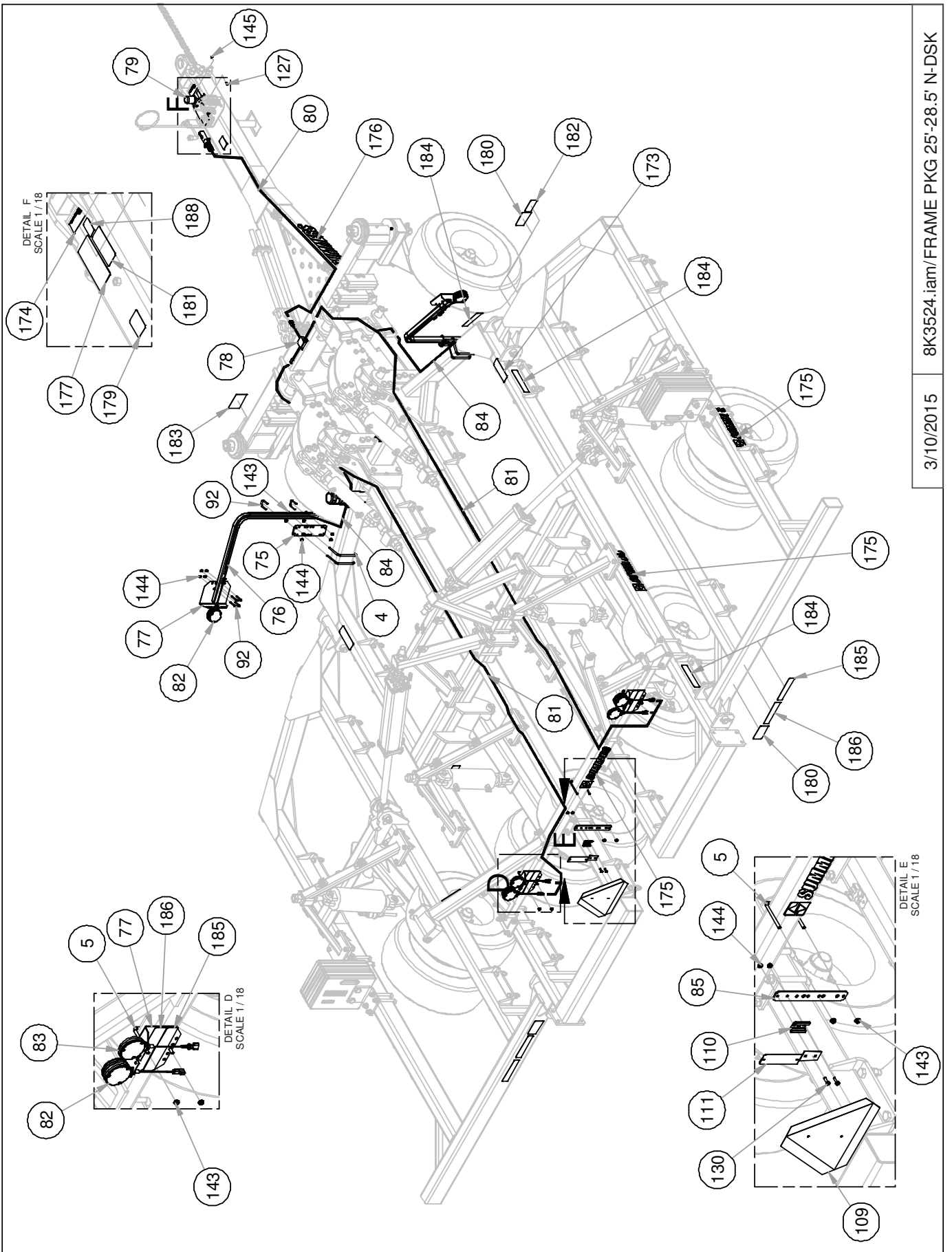

8K3524.iam/FRAME PKG 25'28.5' N-DSK

3/10/2015

DEPTH CONTROL HYDRAULICS

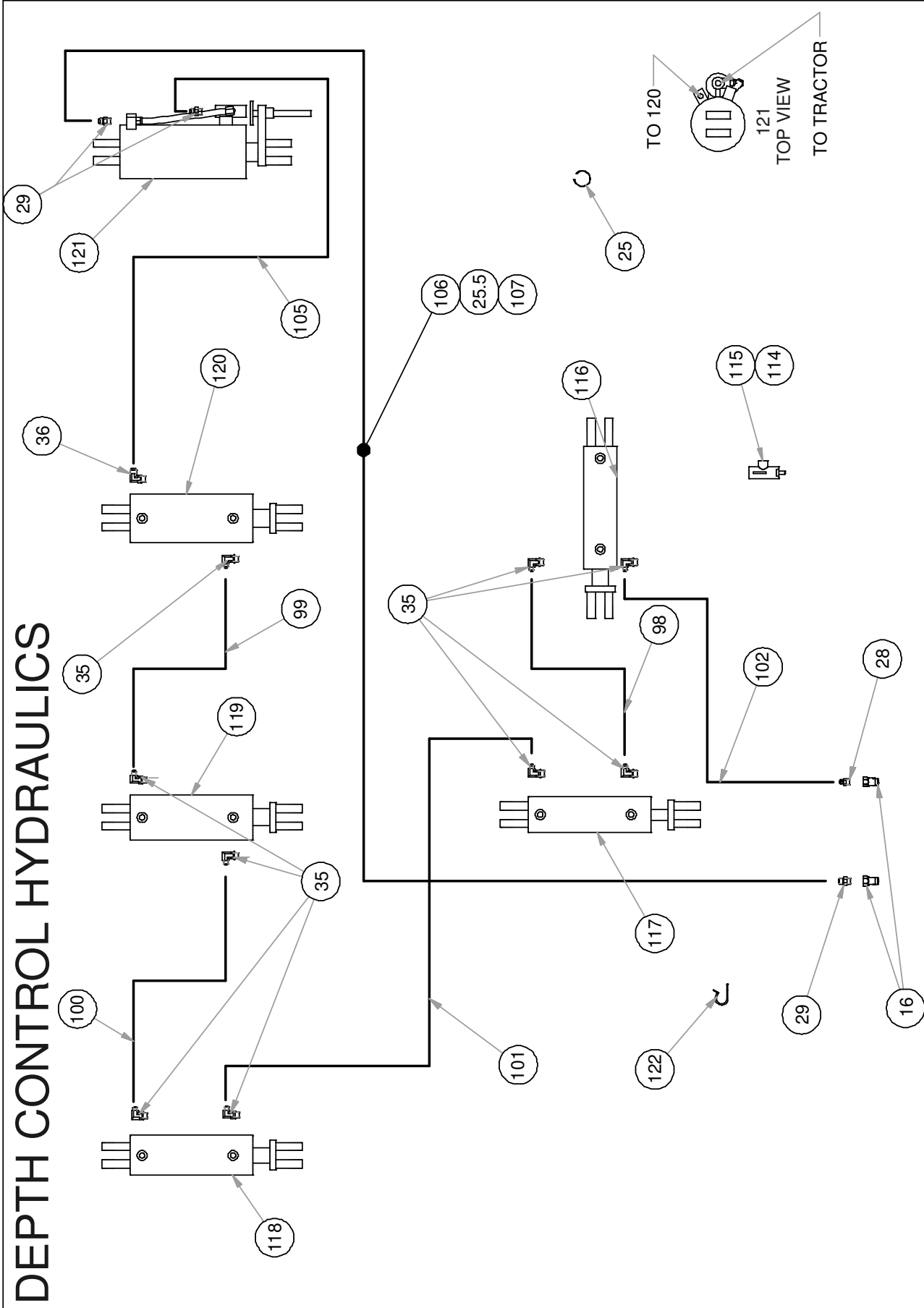

REAR COULTER HYDRAULICS

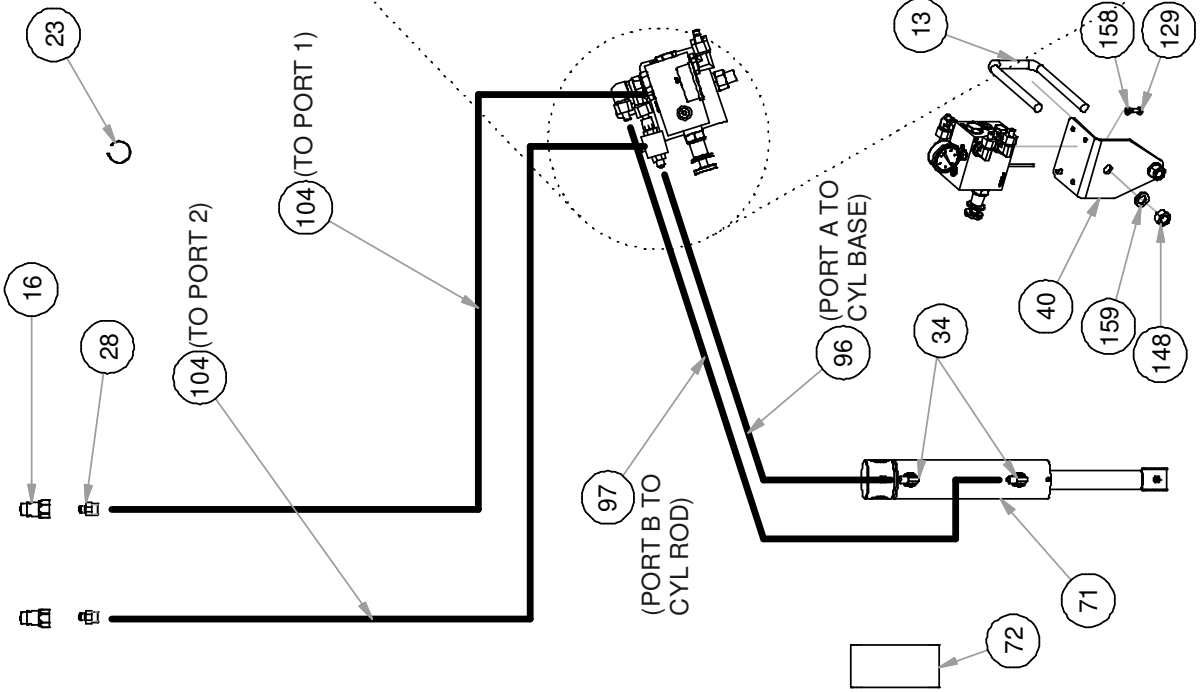

NOTE:
 BLOCK IS CONFIGURED FOR USE ON TRACTORS WITH
 CLOSED-CENTER HYDRAULIC SYSTEMS. FOR USE ON
 OPEN-CENTER HYDRAULIC SYSTEMS, HEX PLUG MUST
 BE MOVED FROM CP1 TO CP2, AND HOLLOW HEX
 PLUG MOVED FROM CP2 TO CP1.

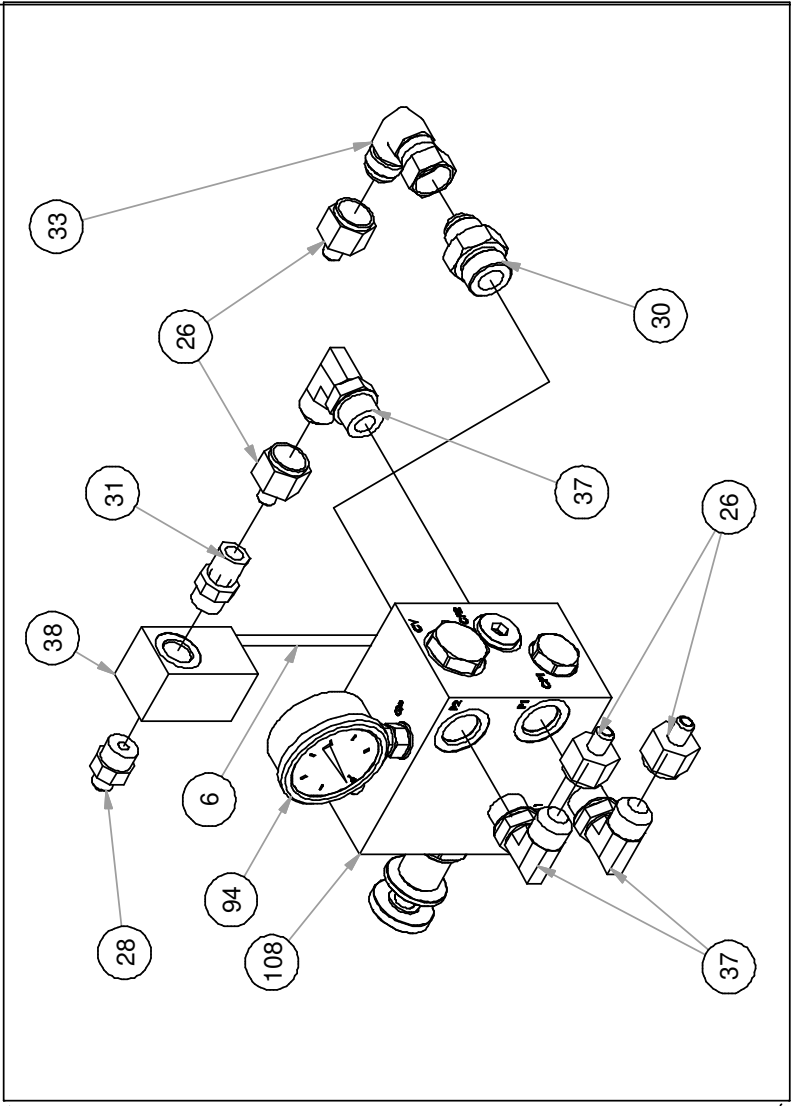

SECTION 2 - ASSEMBLY

ITEM	PN	DESCRIPTION	ITEM	PN	DESCRIPTION	ITEM	PN	DESCRIPTION
1	7L2150	STL 1/2 X 7-1/2"OD X 2-9/16"ID	63	8K1640	PIN 1-1/2 X 10-5/8" HITCH84-	128	8X0015	BOLT 3/8-16NC X 3-3/4" GR5 ZDI
2	7P8530	ROUND CR 2 1/2"-22 1/4" 07-	64	8K1660	PIN 1-1/2 X 15-1/2" HARDEND	129	8X0021	BOLT 5/16-18NC X 3/4" GR5 ZDI
3	8A1004	CLAMP HOSE 5" #72	65	8K1755	YEBOLT 1.50IA X 1.26" EYE X 1.4" YZ	130	8X0021A	BOLT 5/16-18NC X 1" GR5 ZDI
4	8A1155	U-BOLT 3/8 X 6-1/16 X 5" SQ	66	8K1900	SEAL GBGLV WALKING TANDEM 01-	131	8X0044	BOLT 7/16-14NC X 3-1/2" GR5 ZDI
5	8A1156	U-BOLT 3/8 X 4-1/16 X 5" SQ	67	8K1920	RETAINING RING 2-7/8" INV 00-	132	8X0072	BOLT 1/2-13NC X 3-3/4" GR5 YZ
6	8A1954	TUBING GAGE LINE 1/4" OD	68	8K3002	GANG WRENCH	133	8X0110	BOLT 3/4-10NC X 1-1/4" GR5 YZ
7	8A4048	NYLON TIE .18 X 11"	69	8K5200	WASHER GANG BOLT 2.030"ID	134	8X0111	BOLT 3/4-10NC X 2-1/2" GR5 YZ
8	8A4050	NYLON TIE .30 X 8-7/8"	70	8K5515	U-BOLT 3/4 X 4-1/16 X 6" SQ	135	8X0113	BOLT 3/4-10NC X 5" GR5 YZ
9	8A4052	NYLON TIE .30 X 15.25"	71	8K6313	HYD CYL 2.25" X 6" 1.25" ROD	136	8X0121	BOLT 3/4-10NC X 6-1/2" GR5 YZ
10	8CC6018	PARALLEL LINK W/MNT HOLS	72	8K6413	SEAL KIT 2.25X6" CTD 14-	137	8X0133	BOLT 7/8-9NC X 3" GR5 ZDI
11	8CC6020	DIC CHSL PARALLEL LINK	73	8K7042	12.5L X 15 LRF ON 15X10X8 WHL	138	8X0139	BOLT 1-8NC X 3" GR5 ZDI
12	8CC6035	WASHER 2.5X4X 1.281D	74	8K7123	UNT 5/8"-18UNF WHEEL BOLT 97-	139	8X0140	BOLT 1-8NC X 7" W1.5"THDGR5 YZ
13	8D0340	U-BOLT 3/4 X 4-1/16 X 7-3/4" SQ	75	8K8000	STL 7K2045 3/8X3.5 PNTDOLGHT	140	8X0145	BOLT 1-8NC X 10.5" GR5 ZDI
14	8D0350	U-BOLT 3/4 X 4-1/16 X 10" SQ	76	8K8010	TUBE LGHT BRCKT1.55055.5"00-	141	8X0146	BOLT 1-8NC X 8.5" W1.5"THDGR5 ZDI
14.5	8D0720	HITCH PIECE CAST 3CTD PNTD	77	8K8020	MOUNTING BRCKT LIGHT 00-	142	8X0202	NUT 3/8"-16NC NY-LOCK GR2 YZ
15	8D2470	SAFETY CHAIN 7/16" X 5'	78	8K8030A	MODULE AG ENHNC/DWBRK6PINO8-	143	8X0203	NUT 3/8"-16NC SERFLANG GR2 YZ
16	8D3212	MALE TIP 3/4"-16 ORB PIONEER	79	8K8067	DUST CAP FOR 7PIN CONNECT00-	144	8X0211	NUT 5/16"-18NC SERFLANG GR2 YZ
17	8D8490	PIONEER/ISO TIP HLDR BNT	80	8K8070B	MAIN HRNS 7PNLNG WBRKAE 09-	145	8X0223	NUT 1/4"-20NC SERFLANG GR2 YZ
18	8D8500	HYD HOSE HOLDER PNTD BLK 91-	81	8K8075A	EXT HRNS NDRDRAWR DTSCH 07-	146	8X0234	NUT 7/16"-14NC NY-LOCK GR2 ZDI
19	8D8522	JACK 5000# TOP CRANK 15"LIFT	82	8K8090B	LIGHT LED AMBER 2WR DTSCH 12-	147	8X0242	NUT 1/2"-13NC NY-LOCK GR2 YZ
20	8D9108	ROLL PIN 1/4 X 2" YLW ZNC	83	8K8095B	LIGHT LED RED 3WIRE DTSCH 12-	148	8X0260	NUT 3/4"-10NC HEX GR2 YZ
21	8D9124	HAIR PIN CLIP LARGE(CYL PIN)	84	8K8105A	EXT HARNESS 26-2WIRE DTSCH 07-	149	8X0261	NUT 3/4"-10NC SER FLANG GR2 YZ
22	8D9524	HYD CYL 4 X 24" 3000PSI 09-	85	8K8200	BRCKT SWM ATTOCH 4-8"FRAME88-	150	8X0266	NUT 3/4"-10NC SER FLANG GR2 YZ
23	8G2282	NYLON TIE .187 X 7-1/2" RED	86	8K9106	PIN 1-1/4 X 4-3/8" HARDEEN	151	8X0270	NUT 7/8"-9NC CNTRLOCK GR2 YZ
24	8G2284	NYLON TIE .187 X 7-1/2" YELLOW	87	8K9220	ANGLE 6X8X1/2-6.25" WGHT PKG	152	8X0280	NUT 1"-8NC HEX GR2 YZ
25	8G2285	NYLON TIE .187 X 7-1/2" GREEN	88	8K9230	SUITSACE WGHT PNTD 1.25" - 70#	153	8X0282	NUT 1"-14TPI TOPLOCK GR B Z
25.5	8J5110	#10 JIC(M) X #10 JIC (M) UNION	89	8K9246	BUSHING 2.8750XD2.5ID X3"	154	8X0284	NUT 1-1/4"-7NC HEX GR2 YZ
26	8J5200	#10 JIC(F) X #6 JIC(M)HEX BUSH	90	8L0252	WASHER 4.50DX1.28IDX1/4" ZDI	155	8X0285	NUT 1-1/2"-6NC HEX GR2 YZ
27	8J5300	TEE #6 JIC (MALE) 3X	91	8L0258	U-BOLT 5/16 X 1-1/2 X 2-1/2" SQ	156	8X0286	NUT 1-1/2"-6NC JAM GR2 YZ
28	8J5510	3/4"-16 ORB X #6 JIC (M) STR	92	8L0320	PLATE 2PT CASTER WEAR	157	8X0292	NUT 2"-4.5 Hvy HEXSLOT GR2 PLN
29	8J5520	3/4"-16 ORB X #10 JIC(M) STR	93	8N0250	HYD PRESSURE GAGE 2.5"	158	8X0300	LOC KWASHER 5/16" YLW ZNC
30	8J5550	1-1/16" - 12ORB X #10 JIC(M) STR	94	8N0328	3/8 X 28" HYD HOSE #6FJX3000PSI	159	8X0306	LOC KWASHER 3/4" YLW ZNC
31	8J5620	3/4"-16 ORB X #6 JIC(F) STR	95	8N0335	3/8 X 35" HYD HOSE #6FJX3000PSI	160	8X0307	LOC KWASHER 7/8" YLW ZNC
32	8J5700	#6 JIC(F) SW X #6 JIC(M) ADP	96	8N0338	3/8 X 48" HYD HOSE #6FJX3000PSI	161	8X0309	LOC KWASHER 1" YLW ZNC
33	8J5710	#10 JIC(F) SW X #10 JIC(M)90" ADP	97	8N0340	3/8 X 60" HYD HOSE #6FJX3000PSI	162	8X0311	LOC KWASHER 1-1/4" YLW ZNC
34	8J6000	9/16"-18 ORB X #6 JIC(M) 90"ADP	98	8N3124	3/8 X 124" HYD HOSE #6FJX3000PSI	163	8X0316	WASHER 1" SAE FLAT YZ
35	8J6010	3/4"-16 ORB X #6 JIC(M)90"ADP	99	8N3228	3/8 X 150" HYD HOSE #6FJX3000PSI	164	8X0318	WASHER 3/4"(13/16")IDJFLAT YZ
42	8K1134N	LIFT ARM 32.5" WING NARROW	100	8N3258	3/8 X 228" HYD HOSE #6FJX3000PSI	165	8X0320	WASHER 3/8" 7/16" IDJFLAT ZDI
43	8K1152	LIFT ARM 18.5" - 32.5" REAR CNTR	101	8N3252	3/8 X 282" HYD HOSE #6FJX3000PSI	166	8X0327	WASHER 1-1/4" SAE FLAT YZ
37	8J6030	7/8"-14 ORB X #10 JIC(M)90"ADP	102	8N3312	3/8 X 312" HYD HOSE #6FJX3000PSI	167	8X0402	HAIR PIN CLIP 1/8 X 2-9/16"
38	8J7040	THERMAL RELIEF MANIFLD 4000PSI	103	8K6330	3/8 X 390" HYD HOSE #6FJX3000PSI	168	8X0405	SNAPPER PIN 1/4 X 1.5"
39	8J7216	#6JIC(M)X6JIC(F)1/16"RSTR GOLD	104	8N4160	1/2 X 160" HYD HOSE #10FJX3000PSI	169	8X0440	CLEVIS PIN 5/8 X 3-7/8" ZDI
40	8K0050	MNT BRKT ADJ DP MANFLD	105	8N6060	3/4 X 60" HYD HOSE #10FJX3000PSI	170	8X1120	CRG 3/8-16NC X 2" GR2 ZN
41	8K1105S	HUB&AXLE ASSY HD812(2"FCVR)	106	8N6354	3/4 X 354" HYD HOSE #10FJX3000PSI	171	8X1140	CRG 3/8-16NC X 4" GR2 ZN
42	8K1134N	LIFT ARM 32.5" WING NARROW	107	8N7000	ADJ DOWN PRESSURE MANFLD	172	8Z0075	TRANSPORT LOCK DECAL
44	8K1410	HITCH NRRW DSK	108	8S1120	SIGN SLOW MOVING VEHICLE(SMV)	173	8Z0087	DECAL WARNING PINCH POINT03-
45	8K1415	CNTR FRAME NRRW DSK-LEFT	109	8S1126	MOUNTING SOCKET SWM SIGN ZDI	174	8Z0100	MADE IN THE USA DECAL
46	8K1417	CNTR FRAME NRRW DSK-RGHT	110	8S2990	HYD HOSE CLAMP-LARGE NYLON	175	8Z0202	3.5" SUMMERS DECAL
47	8K1420	WING FRAME NRRW DSK-LEFT	111	8S3095	CARPLUG FITS ISO HYD COUPLR 08-	176	8Z0204	5.5" SUMMERS DECAL
48	8K1422	WING FRAME NRRW DSK-RIGHT	112	8T1008	PLASTIC PLUNGER REPAIR KIT	177	8Z0276	GENERAL MACHINE CAUTION DECAL
49	8K1425	TRANSPORT CRSTUBE NRRW DSK	113	8T1010	POPPET	178	8Z0340	REP HASING CYLINDERS DECAL
50	8K1430	SPLICE TUBE FRONT NRRW DSK	114	8T1037	HYD CYL 3.75" X 10"	179	8Z0342	INSTALL CYLLOCKS DECAL
51	8K1435	A-FRAME NRRW DSK	115	8T1045	HYD CYL 4.5 X 10"	180	8Z0344	DECAL WING DANGER
52	8K1440	WINGLOCK NRRW DSK	116	8T1048	HYD CYL 4.5 X 10" REPHASE 96-	181	8Z0346	ELECTROCUTION-TILLAGE EQUIP. DECAL
53	8K1445	TUBE	117	8T1050	HYD CYL 5.0 X 10" REPHASE 96-	182	8Z0350	GANG BEARING GREESE DECAL
54	8K1449	BOLT-ON LINK ARM PIVOT-R	118	8T1055	HYD CYL 5.5 X 10" REPHASE 96-	183	8Z0352	CASTER WHEEL TORQUE DECAL
55	8K1451	BOLT-ON LINK ARM PIVOT-L	119	8T1060	HYD CYL 6 X 10 W/ STRK CNTRL 96-	184	8Z0800	REFLECTOR AMBER ADHSVCK98-
56	8K1452	CAS TR CYL ATTOCH SIDEPLATE DSK	120	8T2990	HYD HOSE CLAMP MTL/RUB BLACK	185	8Z0805	REFLECTOR RED ADHSVCK99-
57	8K1470	CAS TR CYL ATTOCH BOLT-IN	121	8T3300	PIVOT BOLT CHSLTRP&WINGLFT YZ	186	8Z0810	REFLECTOR RED ADHSVBACK 98-
58	8K1475	CAS TER ARM DISK-L	122	8T3620	PIN 1-1/2 X 12-1/2" HRDNDZINC	187	8Z1000	MANUAL-PAK 3DIA X 11.75" 09-
59	8K1477	CAS TER ARM DISK-R	123	8T4132	WLNK TNDM 7.5"C-C 2" ID 98-	188	8Z1000	FEWA DECAL
60	8K1485	WING LIFT CYL ATTOCH NRRW DSK	124	8T4350	TRNS LCK WUJHMW10.5"(2.4RD)	189	8K9230	SUITSACE WGHT PNTD 1.25" - 70#
61	8K1500	DISK CAS TER MNT	125	8T4350	WLNK TNDM 7.5"C-C 2" ID 98-	190	8K9230	SUITSACE WGHT PNTD 1.25" - 70#
62	8K1615	PIN 3/4X10-1/2" SAFETYLOCK	126	8T4350	WLNK TNDM 7.5"C-C 2" ID 98-	191	8K9230	SUITSACE WGHT PNTD 1.25" - 70#
			127	8X0000	BOLT 1/4-20X3/4" FLTTHD GR5 YZ	265	8X0145	BOLT 1-8NC X 10-1/2" GR5 ZDI

SECTION 3 - OPERATION & MAINTENANCE

START-UP AND HYDRAULIC OPERATION

INITIAL START UP PROCEDURE FOR DISK LIFT HYDRAULIC CYLINDERS

This disk has a Master-Slave Hydraulic Lift System. Fully extend hydraulic cylinders and maintain hydraulic pressure for 30 seconds to insure all air is purged from system.

NOTE: As oil is pumped into the base end of master cylinder, oil is forced out of the rod end into the base end of each slave cylinder. To compensate for the smaller volume of oil in the rod end of the master cylinder, each slave cylinder is 1/2" smaller in diameter. When cylinders are fully extended, oil will bypass through a rephasing slot on each cylinder in order to equalize the system. The tractor SCV lever must be held for a few seconds to accomplish this passage of oil through the system.

INITIAL START-UP PROCEDURE FOR WING LIFT HYDRAULIC CYLINDERS

The wing lift hydraulic cylinders on this disk must be charged with oil before attempting to raise the wings.

The best method of performing this is to disconnect the rod end of the fold cylinders from the wings and connect the hoses to the tractor's couplers. Make sure the tractor reservoir is full of manufacturer's recommended hydraulic oil. Extend and retract the cylinders until the action is positive and all air is purged from the system. Due to the amount of oil required to fill the cylinders and lines, additional hydraulic oil may be required. After cylinders have been filled with oil, reconnect the rod ends of the cylinders to the wings.



CAUTION: Stand clear whenever raising or lowering the wings.

Before lowering the wings, remove the safety lock pins and place

them in the storage positions. After wings are lowered, extend cylinders fully.

BEFORE INITIAL OPERATION

1. After receiving or assembling your disk, it is a good practice to double check entire machine so that all bolts are securely tightened.
2. Make sure all grease fittings are in place and greased properly.
3. Inflate all lift tires to the recommended inflation pressure and check wheel bolts. (See Maintenance for specifications.)

AFTER FIRST TWO HOURS OF OPERATION

1. Recheck wheel bolts for tightness and tighten spindle nuts if any side-play is evident in the bearings.
2. Check gang shafts for tightness. This procedure should be repeated daily through the first twenty hours of operation. Gang shafts should be tightened to 1200 foot-pounds.

NOTE: A 1/4" spacer (PN 8X0366) is available and should be installed when the castle nut has been tightened past lock bolt.

3. Bearing and C-shaped shank mounting bolts should be checked for tightness. This procedure should also be repeated daily during the first twenty hours of operation.
4. The scrapers on your disks should be checked and tightened if needed. Scrapers may have to be adjusted periodically to account for wear and different field conditions.

MAINTENANCE

GANG BEARINGS:

Note: Zerks are installed on both front and back of gang bearing cast holders for your convenience. Both zerks lead to the bearing, only one needs to be greased.

To prevent contamination, insure that coupler and zerk are clean.

To maximize bearing life, grease bearings at mid day or end of day when bearings are at operating temperature.

Every 20 hours: Add three strokes (approx. .14 oz.) of grease to gang bearing. Rotate gang 2 to 3 revolutions. Add an additional three strokes of grease.

GENERAL:

Daily: Grease all pivot points located on wing lift, disk lift arms, and hitch.

Check all wheel bolts/nuts for tightness. Recommended torque listed below:

Hub	Wheel Bolt/Nut Torque
812 – 8 Bolt	240 ft-lb

Tighten spindle nuts if any side-play is evident in the bearings.

Maintain disk gang torque at 1200 ft. lb.

Seasonally: Clean and repack wheel bearings.

TIRE INFLATION:

Recommended tire inflations listed below:

Size	Ply	Pressure
12.5L x 15	LRF	90 psi
340/60R16.5	148A8	73 psi (Optional)

SECTION 3 - OPERATION & MAINTENANCE

FIELD OPERATION

The following procedure should be used for field operation of your Summers Diamond Disk & DT9530.

1. Remove wing safety lock pins and transport locks and place in their storage positions.
2. Lower wings for field operation.
3. Level disk. The disk should be adjusted in a level area of the field.

IMPORTANT!

All pressure must be removed from cylinders before adjusting eyebolts. Rest Disk on top of the ground, shut tractor off and relieve pressure by cycling remote lever.

- A. First, level the center section (front to rear) by adjusting the threaded eye bolts connected to each hydraulic cylinder.
- B. Second, level the wings with the center section again by adjusting the threaded eye bolt connected to each hydraulic cylinder.

After determining desired tillage depth, set depth control plunger accordingly. Standard plunger hole spacing gives 5/16" cylinder stroke adjustment. By rotating plunger 90 degrees, a half step adjustment can be achieved. See drawing below.

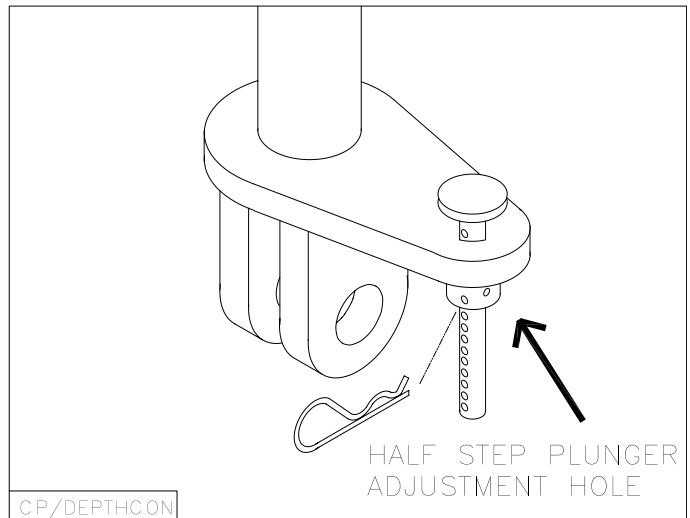

⚠ WARNING

**TO AVOID INJURY
INSTALL CYLINDER
LOCKS BEFORE
TRANSPORTING OR
SERVICING MACHINE.**

8Z0342

IMPORTANT

TO REPHASE CYLINDERS, RAISE MACHINE AND MAINTAIN HYDRAULIC PRESSURE TEN SECONDS AFTER CYLINDERS ARE FULLY EXTENDED. QUICKLY RETRACT CYLINDERS AT LEAST 1/2". REPHASING SHOULD BE DONE EVERY HOUR OF OPERATION TO MAINTAIN UNIFORM TILLAGE DEPTH .

8Z0340

SECTION 3 - OPERATION & MAINTENANCE

REAR COULTER GANG

IMPORTANT: Rear coultter gang is designed to work with active hydraulic down pressure. See note on Page 4-7 to configure to either closed-center or open-center hydraulic system tractors.

1. Plug rear coultter gang hydraulic hoses into desired tractor outlet. Insure that tips and couplers are clean. At the tractor, adjust hydraulic flow to 30% of maximum and to constant vs. timed output.
2. Do not allow anyone to stand near rear coultter gang when raising or lower. Lower rear coultter gang with tractor hydraulics and engage circuit in lower position, do not run this hydraulic circuit in neutral/locked position. Adjust rear coultter gang down pressure with base end regulator to 500 PSI.
3. Work a test strip in your field. Insure that the DK/DT is tilling at an equal depth across machine width. Check penetration depth of rear coultter blades, regulator valve pressure can be adjusted lower or higher to maintain effective cutting depth. Maximum regulator pressure is 1500 PSI.

IMPORTANT: Damage to DK or DT and rear coultter gang may occur if run with hydraulic circuit in neutral/locked position. Damage caused by running with hydraulic circuit in neutral/locked position is not covered by Summers warranty.

Monitor temperature of tractor hydraulic oil. Discontinue use of rear coultter gang live hydraulic down pressure if hydraulic oil becomes excessively hot. If this occurs, run rear coultter gang hydraulic circuit in Float Position Only until cause of overheating is resolved. Contact your Summers Dealer for troubleshooting information. Damage caused by overheating of tractor hydraulic system is not covered by Summers warranty.

4. If the soil profile behind the rear coultter gang shows a valley or depression, not enough soil is flowing between the rear center blades. Lower the front of the DK/DT to increase the amount of soil running thru the implement center.

If a mound of soil appears behind the rear coultter gang, too much soil is flowing between the rear center blades. Raise the front of the DK or DT to reduce the amount of soil running thru the implement center.

5. If equipped with Adjustable Rear Coultter Gang, fine tuning can be accomplished by changing the angle of the coultter gangs. Rotating the crank handle counter-clockwise will increase the gang angle, resulting in the coultter blades pulling more soil away from center strip. Rotating the crank handle clockwise will decrease (straighten) the gang angle, resulting in less soil movement.

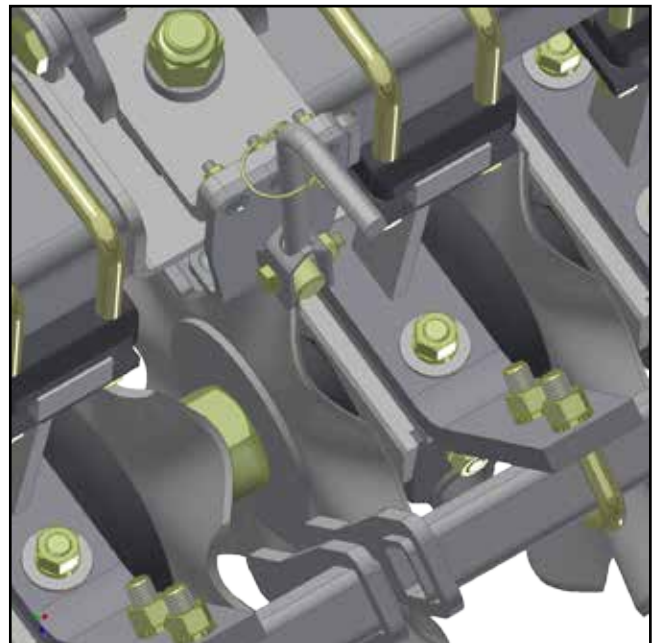

SECTION 3 - OPERATION & MAINTENANCE

TRANSPORTING

The Summers Diamond Disk & DT9530 are equipped with manual wing and center lift cylinder locks. The following procedure should be used to prepare disk for transport.

1. Check that wing locks are in the storage positions.
2. Fully extend main lift cylinders, quickly lower disk approximately 1", raise wings.
3. Install safety locks on wings and center lift cylinders.
4. USE a safety chain between tractor drawbar and disk hitch when transporting on public roads.

5. Check wheel bolts / nuts after first 20 miles of road transport and every 60 miles thereafter.
Road the implement at a reasonable speed not to exceed 20 miles per hour.

Always use an ASAE "Slow Moving Vehicle" emblem and Safety Lights when transporting on a road or highway. Comply with your state and local laws governing lighting and maximum width regulations. Transport during daylight hours only.

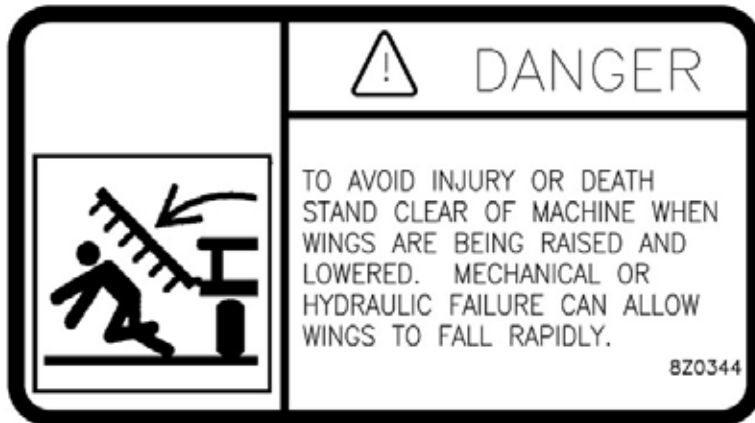

STORAGE

Proper rust prevention treatment of equipment before placing in storage will not only lengthen its useful life, but will assist in maintaining optimum performance when put back into service.

The following list contains suggestions for preparing your implement for storage.

1. Clean entire machine. Remove all dirt and excessive grease from implement.
2. Check disk over thoroughly for damaged or worn parts, cracked or broken blades, and loose bolts.
3. Wheel bearings should be cleaned and repacked each year.
4. Grease all zerks on implement.
5. Block up to remove weight from tires.
6. If implement is lowered to the ground, place boards under blades.
7. Disconnect rods and fully retract the cylinders to prevent rusting of shafts and subsequent seal damage. If left extended, coat rods with grease to prevent corrosion. Remove grease prior to retracting cylinders.
8. For safety, do not store implement with wings folded up.
9. Clean and place a protective coating of heavy oil or grease on earth-working parts to prevent rusting.
10. Touch-up any spots where paint has been scratched or worn off.

SECTION 3 - OPERATION & MAINTENANCE

TROUBLESHOOTING

NO.	PROBLEM	CAUSE	CORRECTION
1	Leaving center valley	Rear gangs cutting too deep.	Level disk using threaded adjustment bolts above each cylinder/wheel assembly. Diamond Disk - Install additional 2 8K5025N blades at rear center.
2	Gangs plugging.	Extremely wet field conditions.	Allow to dry if possible.
		Scrapers adjusted improperly.	Adjust scrapers so scraping edge is flush against each blade, but not tight enough to prevent gang from turning freely. Under some soil and residue conditions, scrapers will perform better if set 1 to 1-1/4" away from blades.
			Adjust machine to run rear gangs deeper.
3	Poor penetration, center section.	Disk not running level from front to rear.	Level disk using threaded adjustment bolts above each cylinder/wheel assembly.
		Wheels are holding disk out of the ground.	Retract hydraulic cylinders for desired depth.
4	Hydraulic cylinders not synchronized.	Hydraulics have drifted or air has entered the system.	Hold hydraulic control lever with the hydraulic cylinders fully extended 15 seconds to synchronize rephasing cylinders.
5	Leaving ridge 2-4 feet from disk center.	Side draft.	Level disk using threaded adjustment bolts above each cylinder/wheel assembly.
			Recheck gang spacing.
6	Plugging at disk front center.	Wet conditions or extremely high residue conditions.	Level disk using threaded adjustment bolts above each cylinder/wheel assembly.
7	Wings do not penetrate.	Dry/hard conditions.	Adjust wing cylinders to lift wheels off ground.
8	Gang bolts do not stay tight.	Gangs have run loose for extended time.	Disassemble gang, clean and replace worn components.

DIMENSIONS

SIZE	APPROX. TRANSPORT WIDTH	APPROX. TRANSPORT HEIGHT	BASE MACHINE WEIGHT	WEIGHT W/3 BAR M104	WEIGHT W/ ROLLING BSKTS	APPROX. LENGTH W/ ROLLING BSKTS
16'	16'6"	6'6"	13,400#	14,451#	14,823#	31'6"
21'	16'	10'	18,600#	19,937#	20,500#	31'6"
25'	16'2"	10'8"	22,100#	23,526#	24,329#	31'6"
28'6"	16'2"	13'9"	23,300#	24,834#	25,636#	31'6"

SECTION 3 - OPERATION & MAINTENANCE

PROPER BOLT USE

DO NOT use these values if a different torque value or tightening procedure is given for a specific application. Torque values listed are for general use only. Check tightness of fasteners periodically.

BOLT SIZE	WRENCH SIZE	GRADE 5		GRADE 8	
		ft-lbs	N • m	ft-lbs	N • m
1/4"	7/16" or 3/8"	7	9.5	12	17
5/16"	1/2"	15	20	25	34
3/8"	9/16"	30	41	45	61
7/16"	5/8" or 11/16"	45	61	70	95
1/2"	3/4"	70	95	105	142
9/16" wheel bolts	7/8"	170	231		
5/8"	15/16"	170	231	210	285
5/8" wheel nuts	1-1/16"	240	325		
3/4"	1-1/16"* or 1-1/8"	250	339	375	509
7/8"	1-5/16"	350	475	600	814
1"	1-1/2"	450	610	880	1193
1-1/4"	1-7/8"	500	678		
1-1/2"	2-1/4"	570	773		
2"	3-1/8"	1200	1627		

*Nylon Lock Nut

3/8/12 TILLAGE

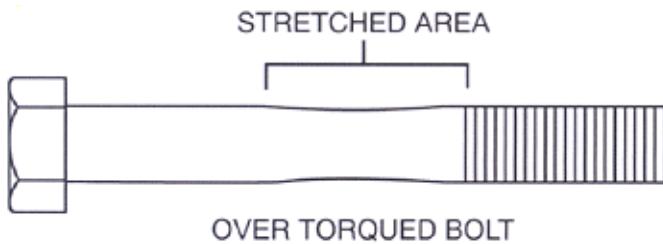

SAE
GRADE 5



SAE
GRADE 8

SECTION 4 - PARTS

BRING OWNER REGISTER INFORMATION LOCATED AT THE BEGINNING OF THIS MANUAL WHEN ORDERING PARTS (SERIAL NUMBER IS LOCATED AT FRONT OF DISK BY HITCH PIECE).

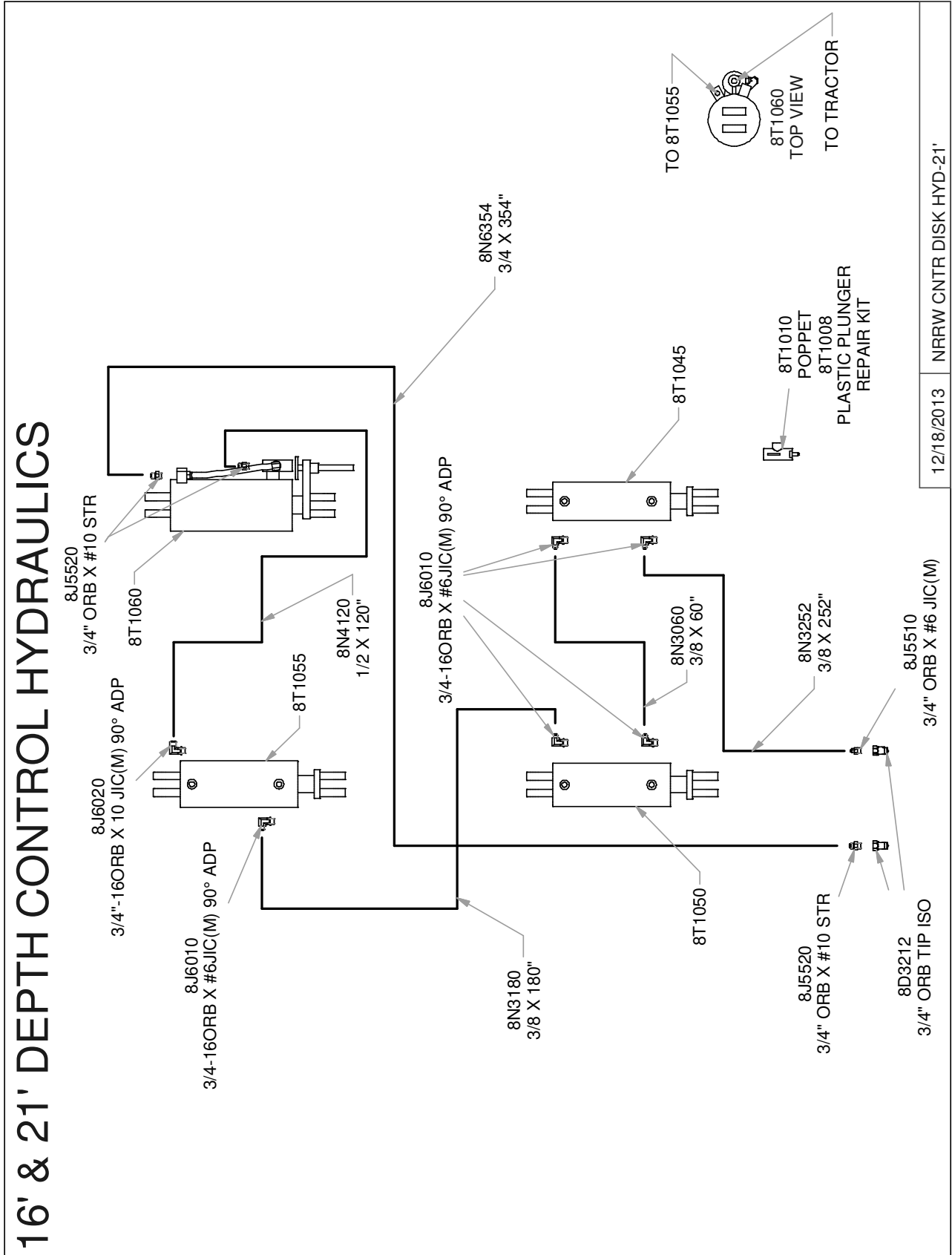

25' & 28 1/2' DEPTH CONTROL HYDRAULICS

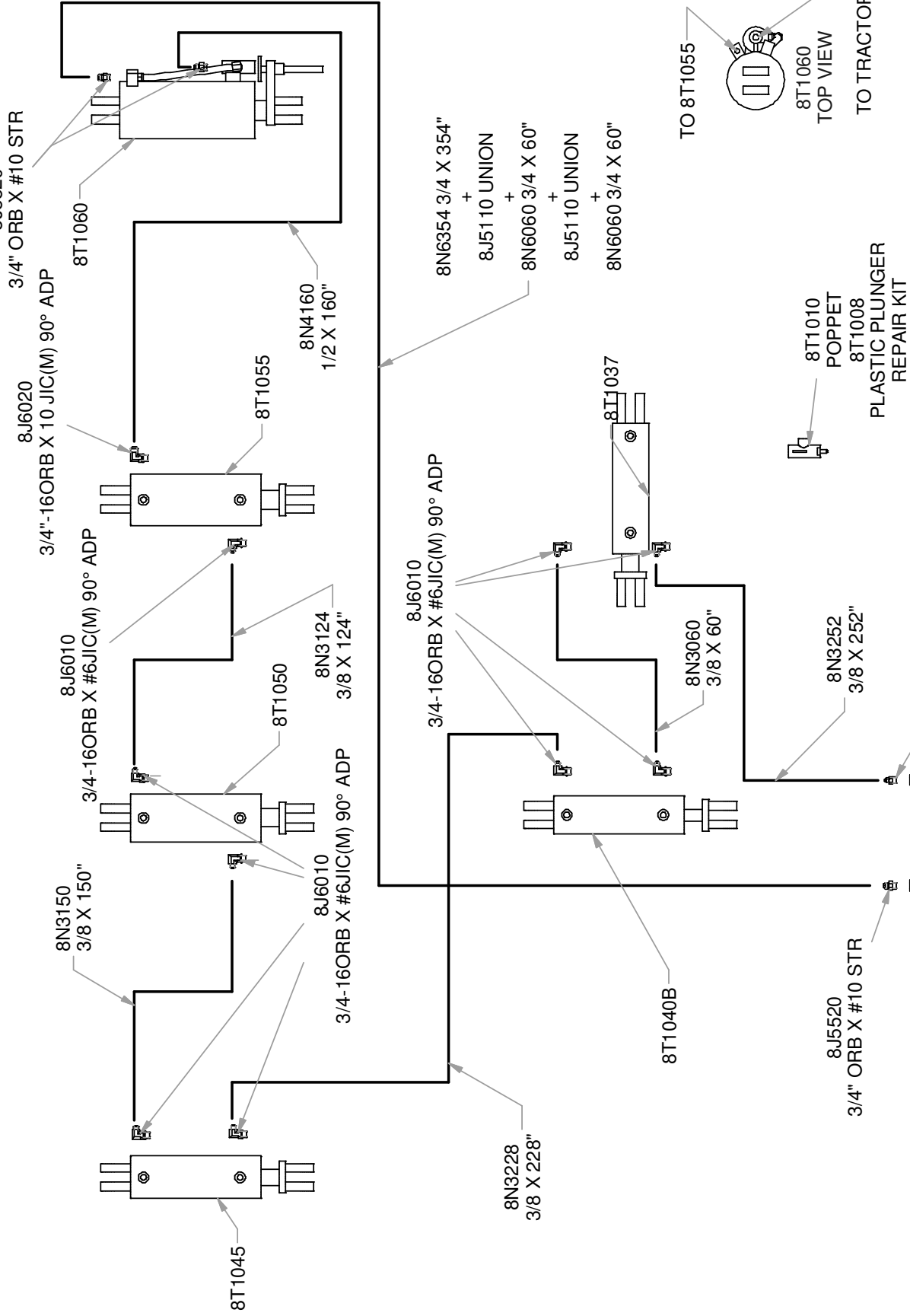

8/27/2013 NRRW CNTR DISK HYD

SECTION 4 - PARTS

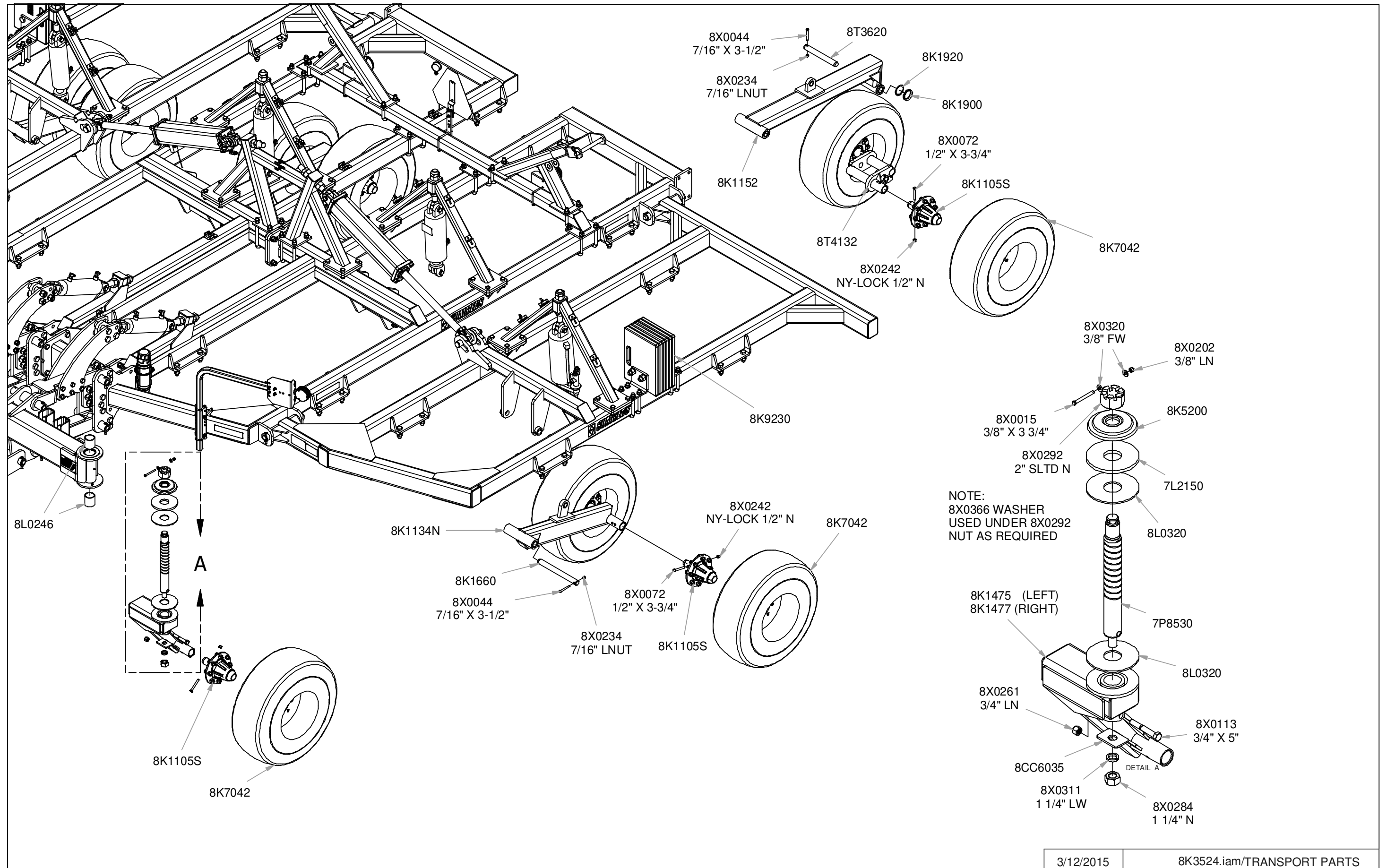

21' WING FOLD HYDRAULICS

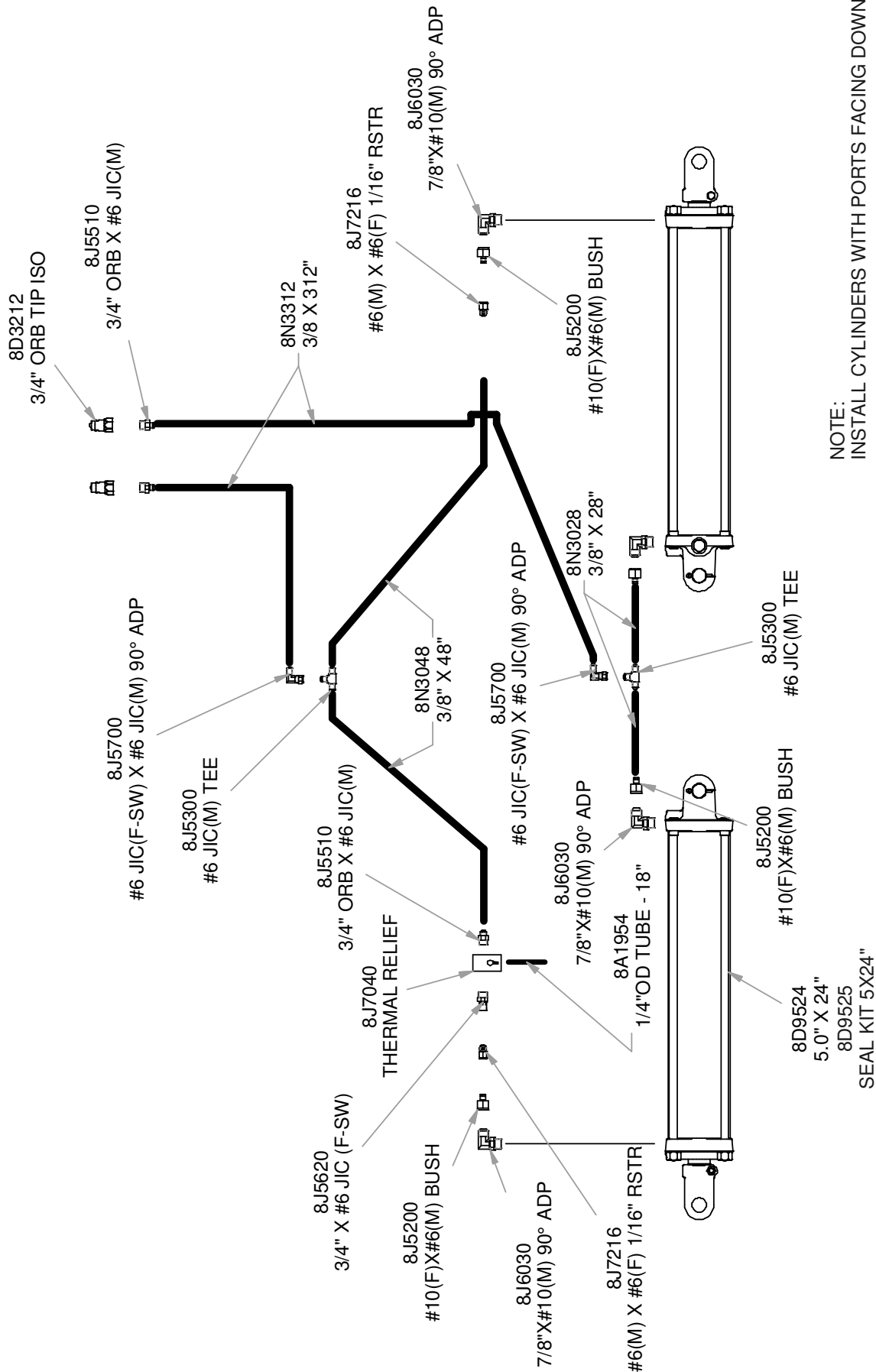

NOTE:
INSTALL CYLINDERS WITH PORTS FACING DOWN.

12/18/2013 NRRW CNTR DISK HYD-21'

25' & 28 1/2' WING FOLD HYDRAULICS

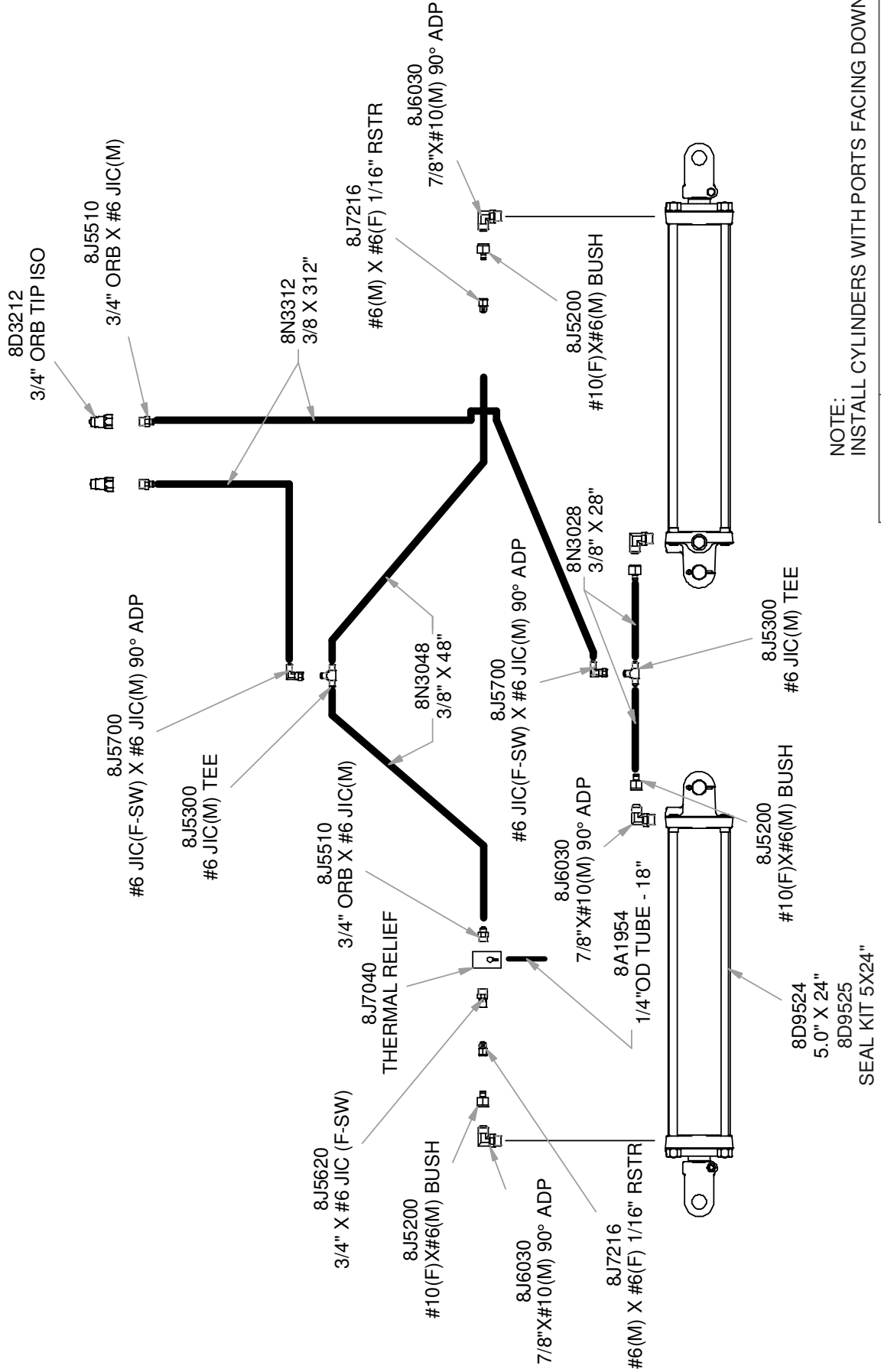

NOTE:
INSTALL CYLINDERS WITH PORTS FACING DOWN.

8/27/2013 NRRW CNTR DISK HYD

REAR COULTER HYDRAULICS

NOTE:
 BLOCK IS CONFIGURED FOR
 USE ON TRACTORS WITH
 CLOSED-CENTER HYDRAULIC
 SYSTEMS. FOR USE ON
 OPEN-CENTER HYDRAULIC
 SYSTEMS, HEX PLUG MUST
 BE MOVED FROM CP1 TO
 CP2, AND HOLLOW HEX
 PLUG MOVED FROM CP2
 TO CP1.

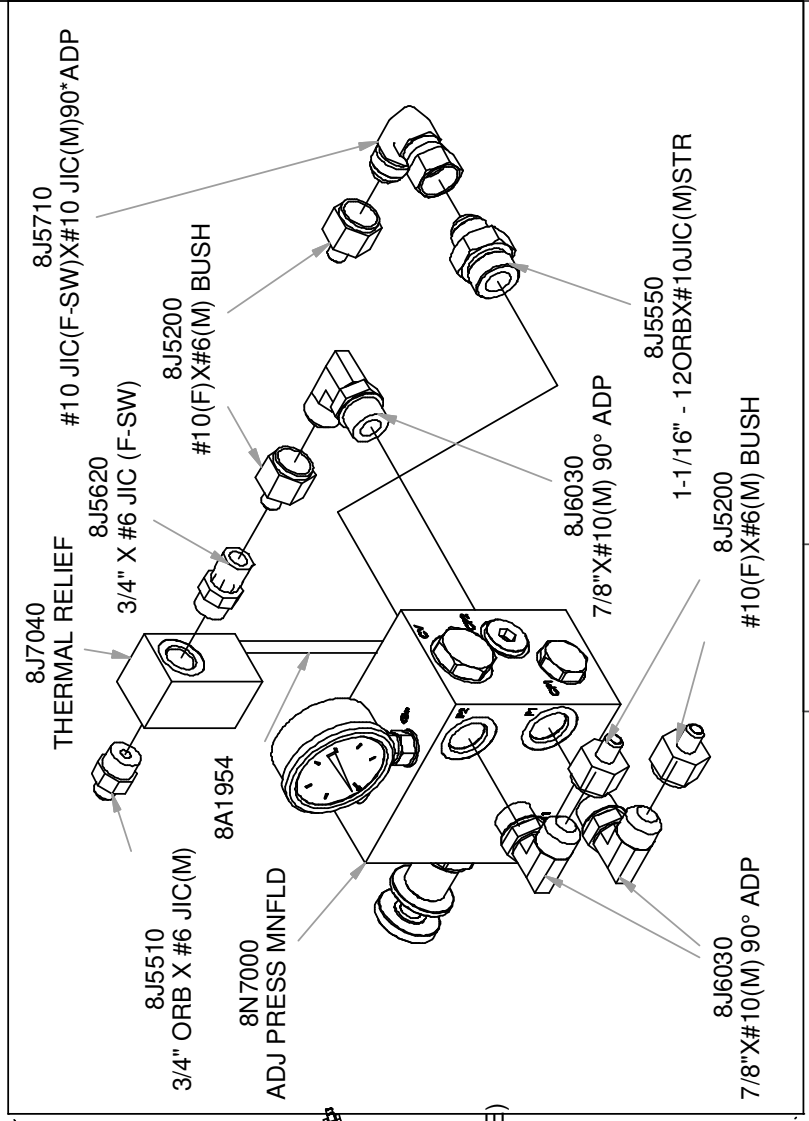
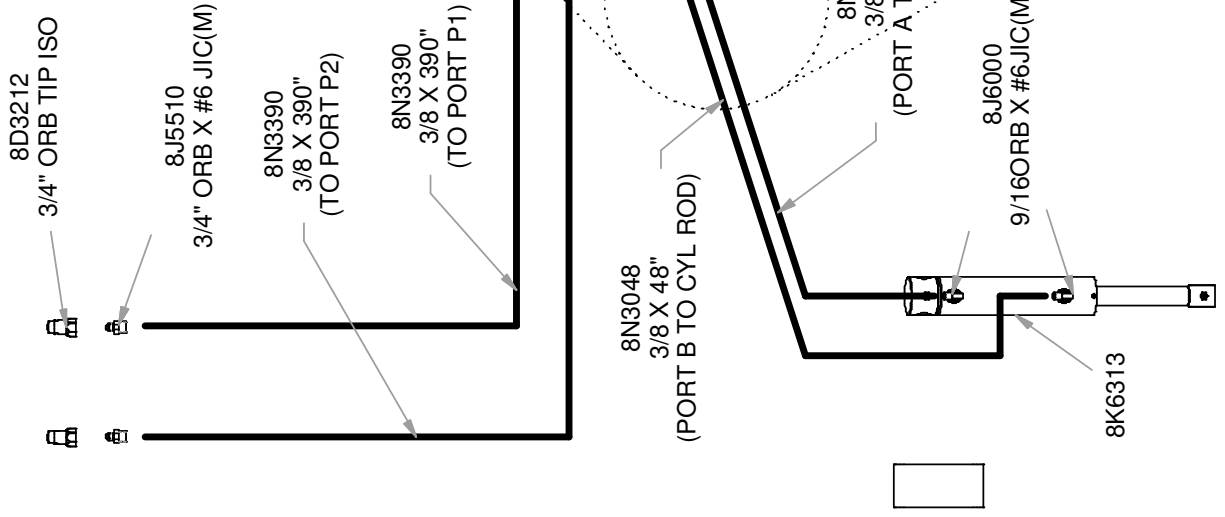

8/27/2013 NRRW CNTR DISK HYD

SECTION 4 - PARTS

16' NARROW
DISK/DT
GANG
LAYOUT
(8K3316)

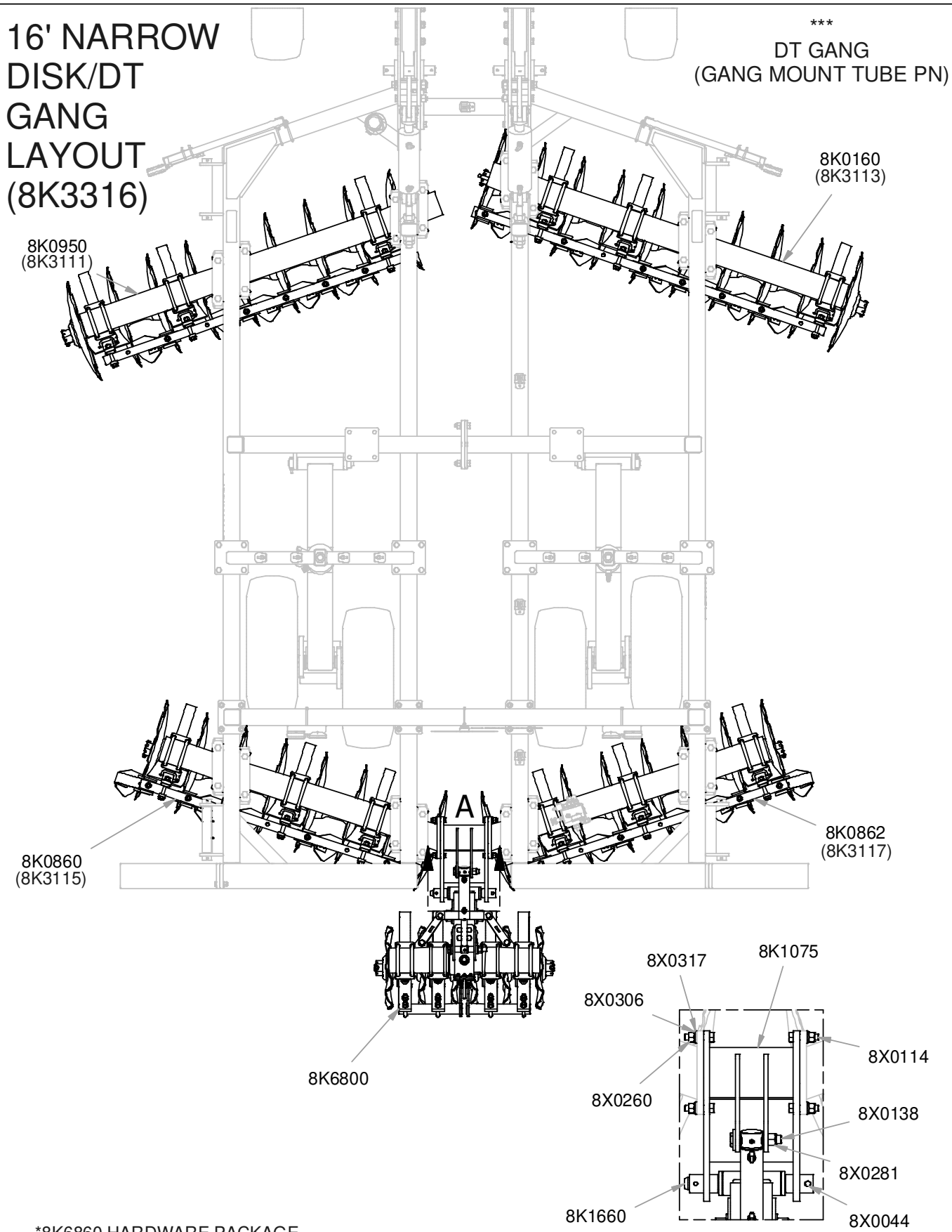

*8K6860 HARDWARE PACKAGE

9/3/2014

16' N-DISK.iam/GANG LAYOUT

21' NARROW DISK/DT
GANG LAYOUT

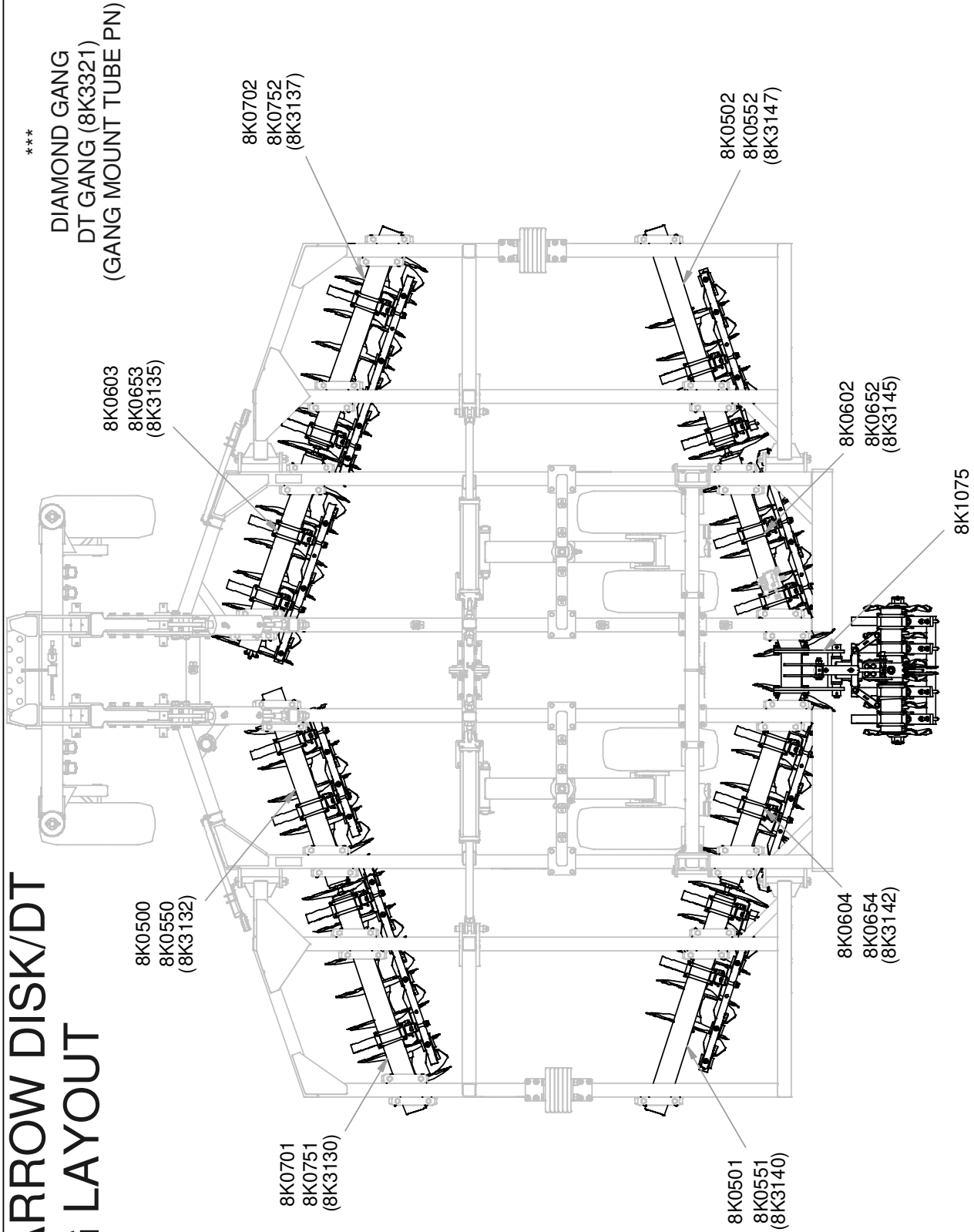

*8K6860 HARDWARE PACKAGE

9/3/2014

21' N-DISK.iam/GANG LAYOUT

25' NARROW DISK/DT GANG LAYOUT

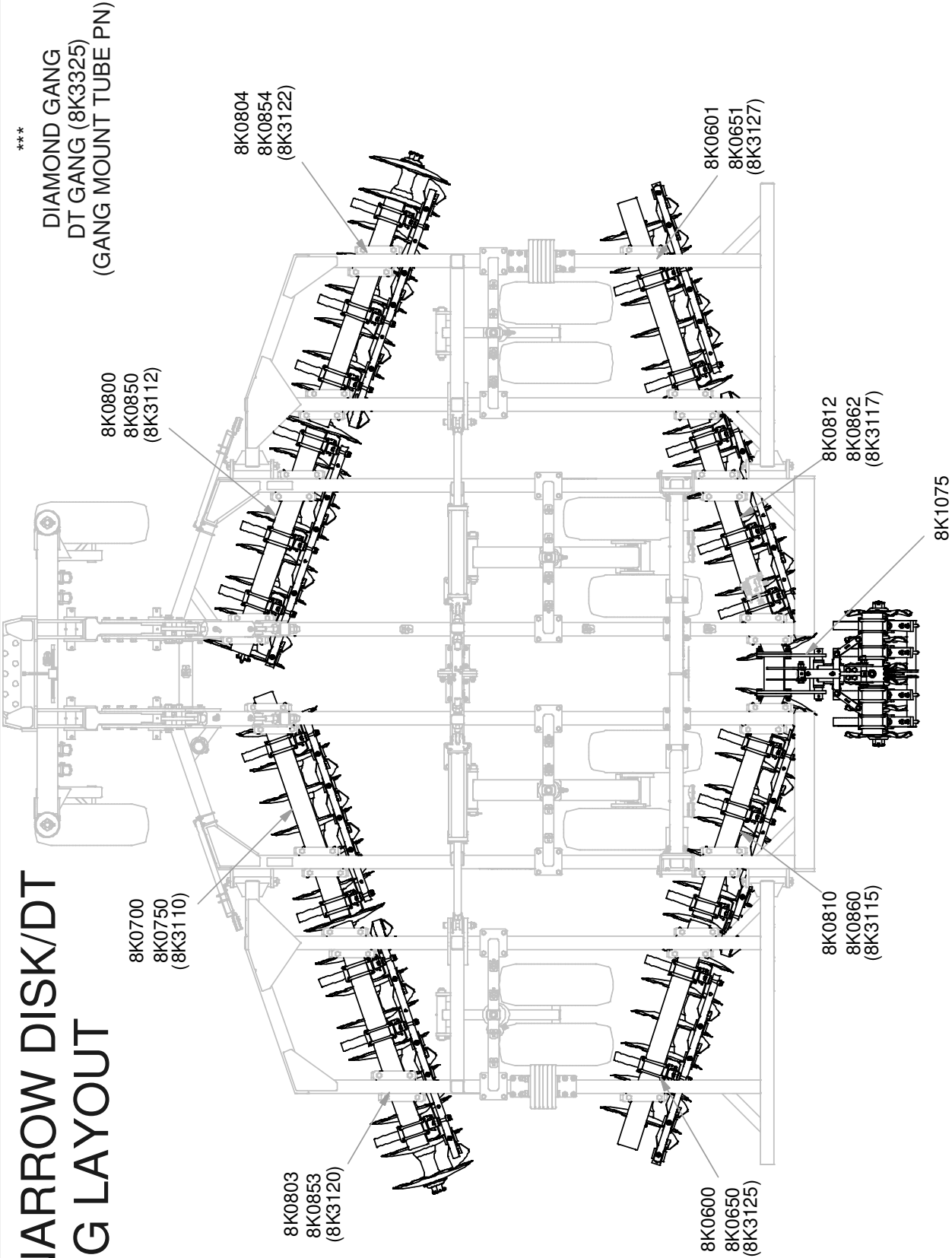

*8K6860 HARDWARE PACKAGE

9/3/2014

25' N-DISK:iam/GANG LAYOUT

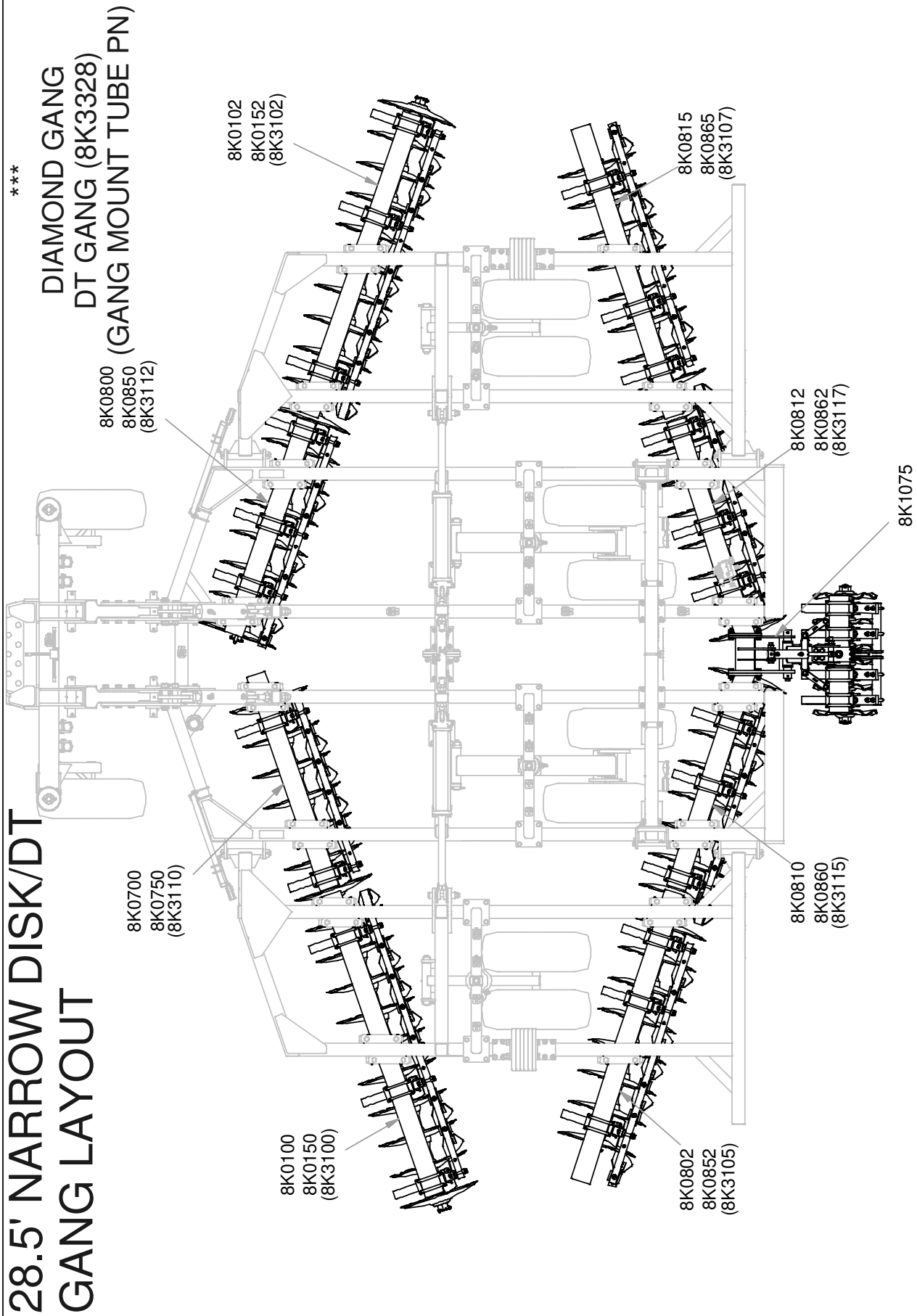

*8K6860 HARDWARE PACKAGE

10/7/2014

28.5' N-DISK.iam/GANG LAYOUT

SECTION 4 - PARTS

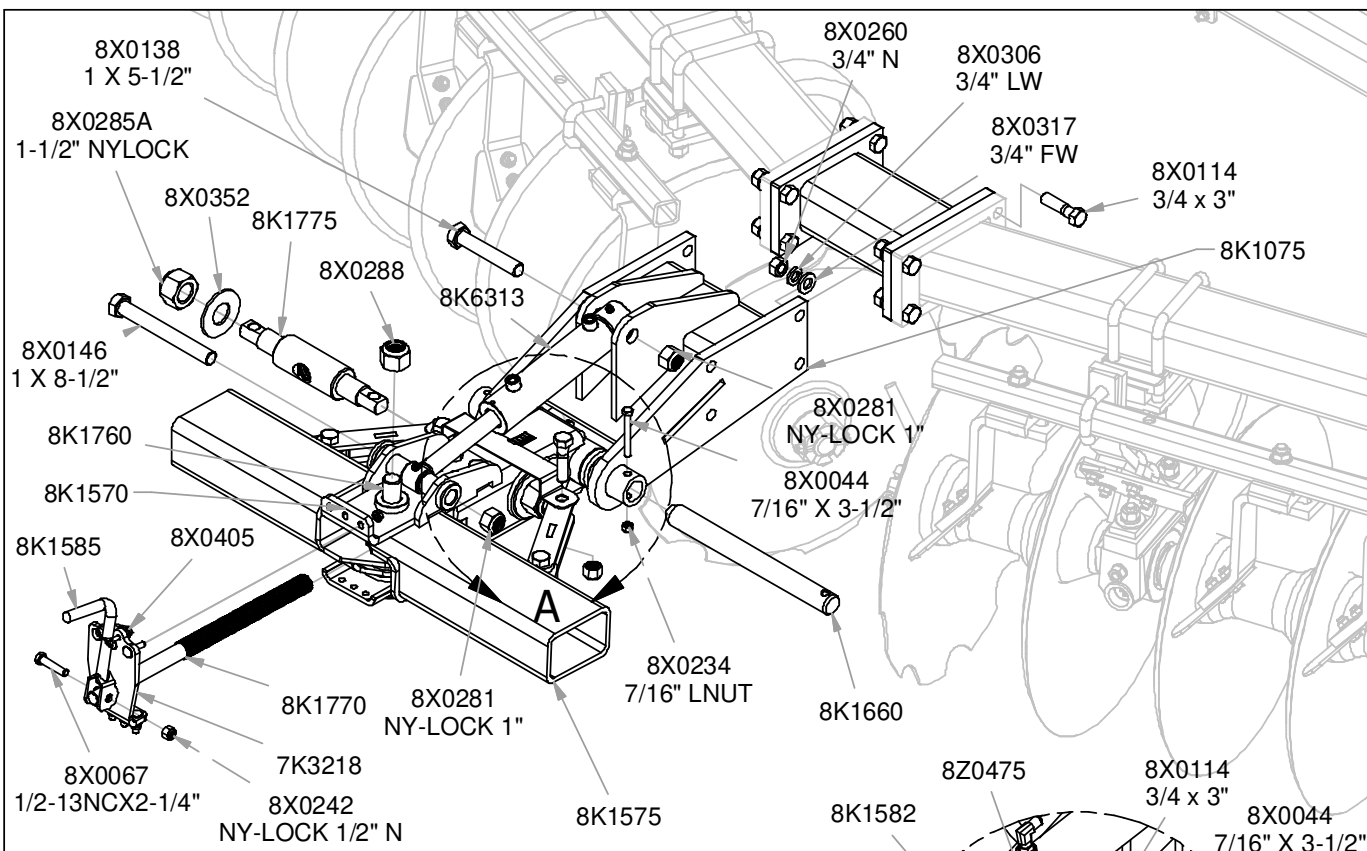

1. INSTALL 8K1075 SPLICE TUBE WITH HARDWARE AS SHOWN, AND TIGHTEN.
2. INSTALL 8K1560 GANG HOUSING WITH 8K1660 PIN. RETAIN WITH 8X0044 BOLT AND 8X0234 NUT.
3. INSTALL 8K6313 CYLINDER AS SHOWN WITH 8X0138 BOLT AT BASE END OF CYLINDER, AND 8X0146 BOLT AT ROD END. INSTALL 8X0281 NUTS AND TIGHTEN. **DO NOT OVERTIGHTEN.** CYLINDER MUST BE FREE TO ROTATE.
4. ATTACH 8K1575 GANG MOUNT TUBE IN LEFT LOCATION USING 8K1760 BOLT AND 8X0288 NUT. DO NOT OVERTIGHTEN, AS THE GANG TUBE MUST BE FREE TO ROTATE, BUT STILL SNUG.
5. ATTACH SECOND 8K1575 GANG MOUNT TUBE, IN THE SAME MANNER, IN RIGHT LOCATION TO 8K1570 AS SHOWN.
6. ATTACH 8K1570 TO 8K1560 AS SHOWN.

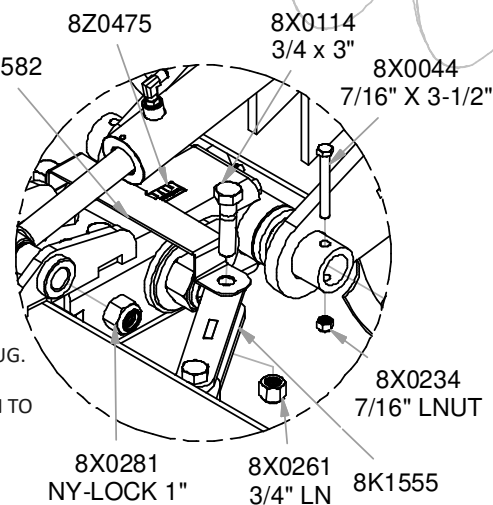

7. ATTACH HOUSING TO 8K1075 SPLICE TUBE WITH 8K1660 PIN AS SHOWN. NEXT CONNECT ROD END OF 8K6313 CYLINDER TO HOUSING AS SHOWN.
8. INSERT 8K1775 SLIDE SHAFT INTO HOUSING AND RETAIN WITH 8X0352 WASHERS AND 8X0285A NYLOCK NUTS (FROM EACH SIDE). ****DO NOT TIGHTEN NUTS.**
9. THREAD 8K1770 ADJUSTMENT SCREW INTO 8K1775 SLIDE SHAFT UNTIL THERE IS APPROXIMATELY 16" FROM THE REAR END OF ADJUSTMENT SCREW TO THE SLIDE SHAFT.
10. ATTACH 8K1580 REAR CAP WITH 8X1115 CARRIAGE BOLTS AND 8X0203 FLANGE NUTS, PASSING 8K1770 ADJUSTMENT SCREW THROUGH HOLE IN CAP AS SHOWN.
11. TIGHTEN NUTS ON BOTH ENDS OF SLIDE SHAFT, TAKING CARE TO ENSURE THE SLIDE SHAFT IS CENTERED IN THE HOUSING.
12. INSTALL 8K1555 LINK BARS TO SLIDE SHAFT AND GANG MOUNT TUBES. INSTALL 8K1582 ANGLE GAUGE OVER THE TOP OF HOUSING AS SHOWN AND SECURE USING 8X0114 BOLTS AND 8X0261 NYLOCK NUTS.
13. ATTACH 8K1585 CRANK HANDLE TO ADJUSTMENT SCREW WITH 8X0067 BOLT AND 8X0242 NUT. 8X0405 PIN IS PROVIDED TO RETAIN THE HANDLE AND PREVENT UNWANTED MOVEMENT OF THE ADJUSTMENT SCREW.

14. ROTATE HANDLE TO ENSURE THE GANG MOUNT TUBES PIVOT FREELY, AND WITHOUT EXCESSIVE INPUT FORCE ON THE HANDLE.

7/25/2018

9K2827.iam/SPLICE&GANGTUBE INSTALL

SECTION 4 - PARTS

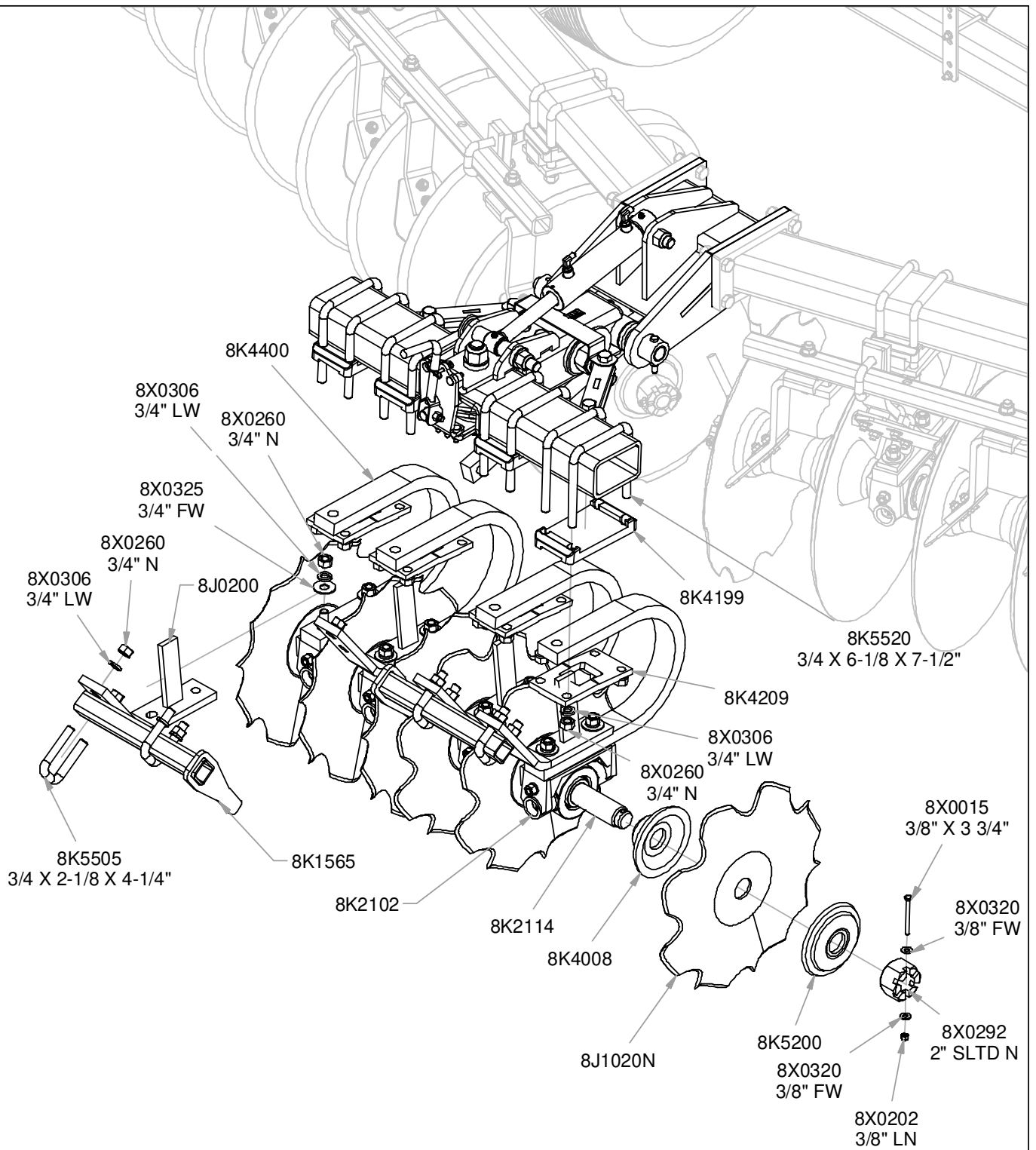

1. INSTALL 8J2230WR AND 8J2230WL GANGS AS SHOWN. LEAVE 8K5520 U-BOLTS LOOSE TO ALLOW CENTERING OF THE GANG. ONCE GANG HAS BEEN CENTERED ON MACHINE, TIGHTEN U-BOLTS.
2. INSTALL 8K1565 SCRAPER MOUNT TUBES, AS SHOWN. CENTER TUBES ON GANG.

7/25/2018

9K2827.iam/CLTR GANG INSTALL

SECTION 4 - PARTS

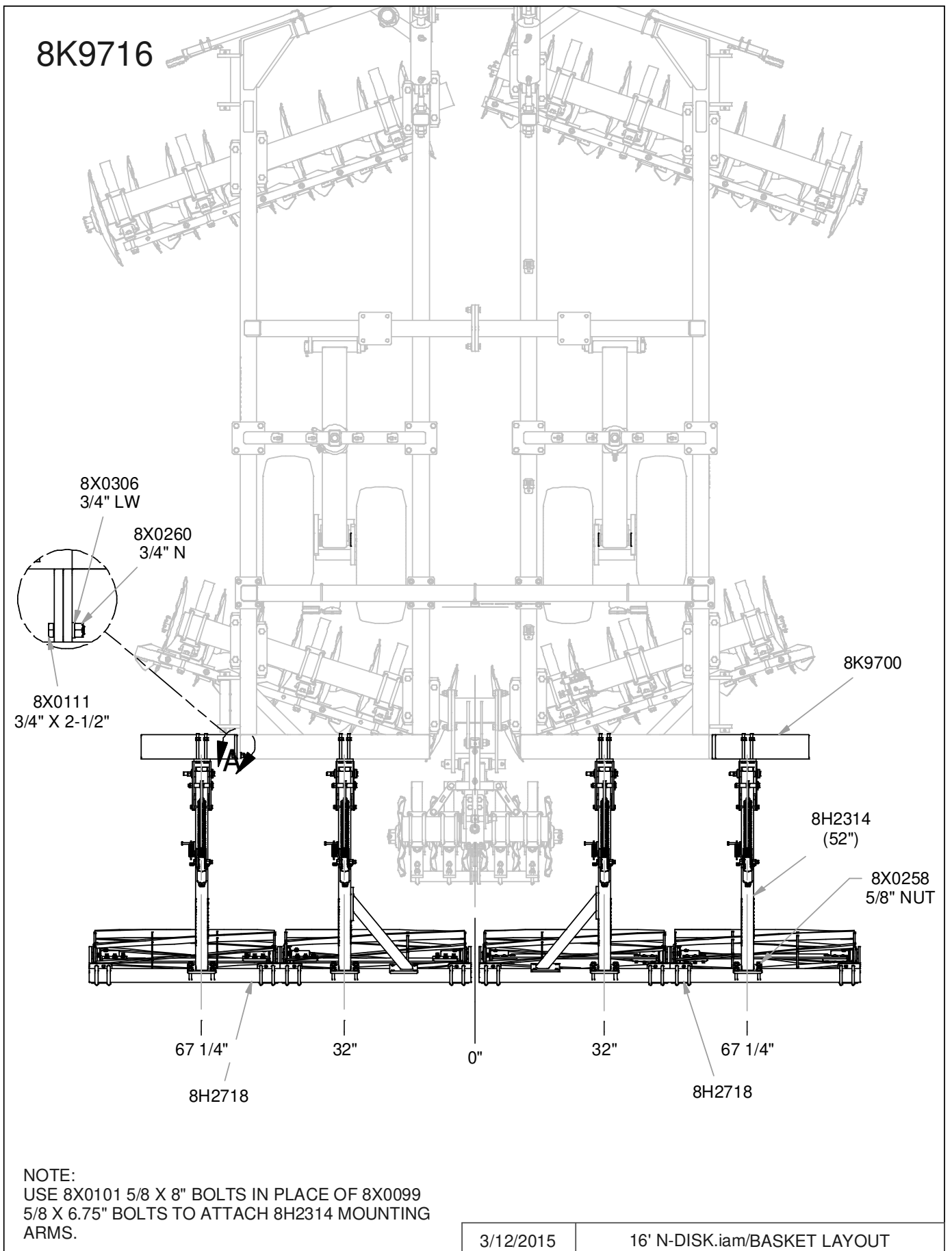

SECTION 4 - PARTS

8K9722

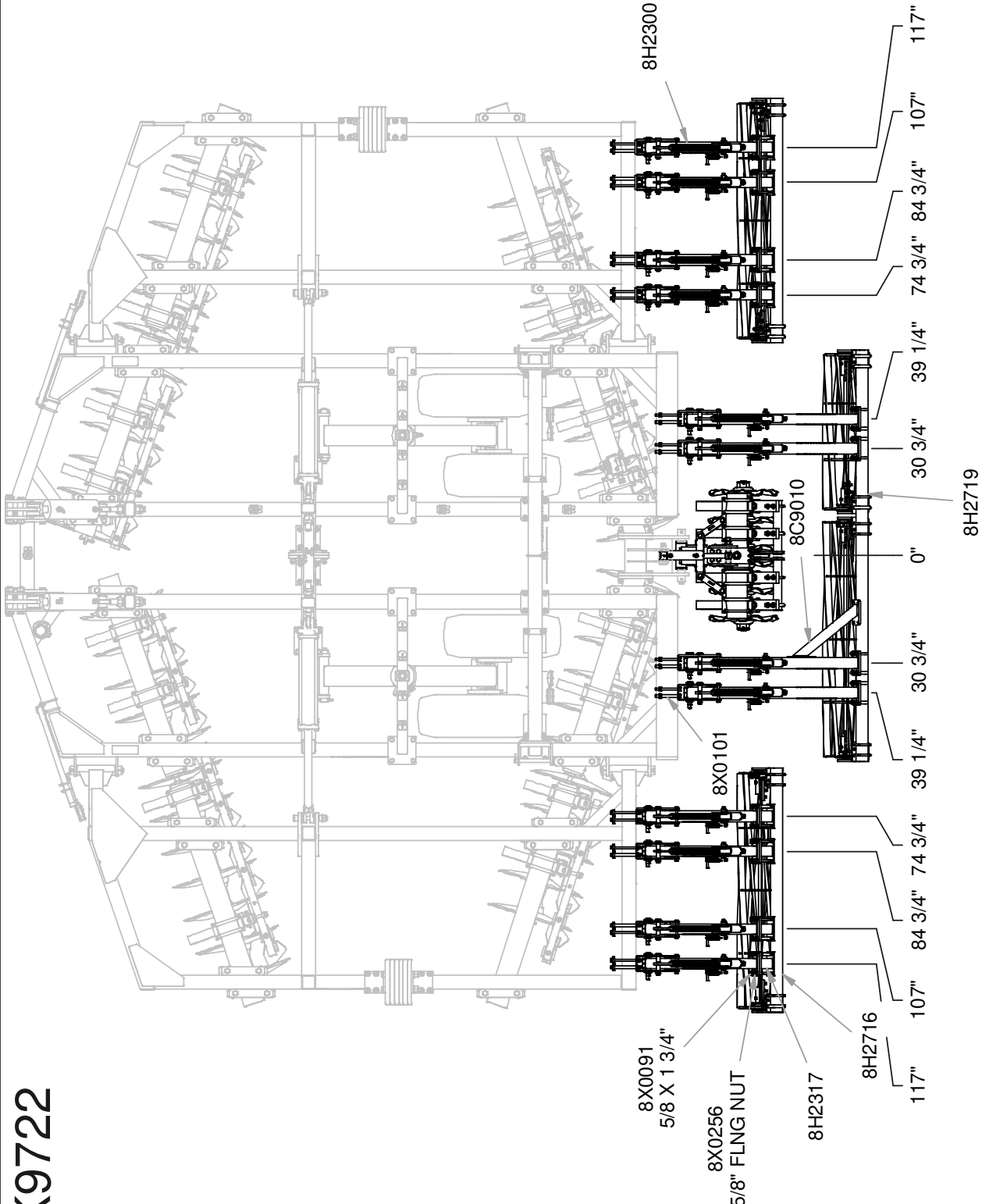

NOTE:
 USE 8X0101 5/8 X 8\" BOLTS IN PLACE OF 8X0099 5/8 X 6.75\" BOLTS
 TO ATTACH 8H2314 MOUNTING ARMS (4) ON CENTER SECTION.

3/18/2015 21' N-DISK.i am/BASKET LAYOUT

SECTION 4 - PARTS

8K9726

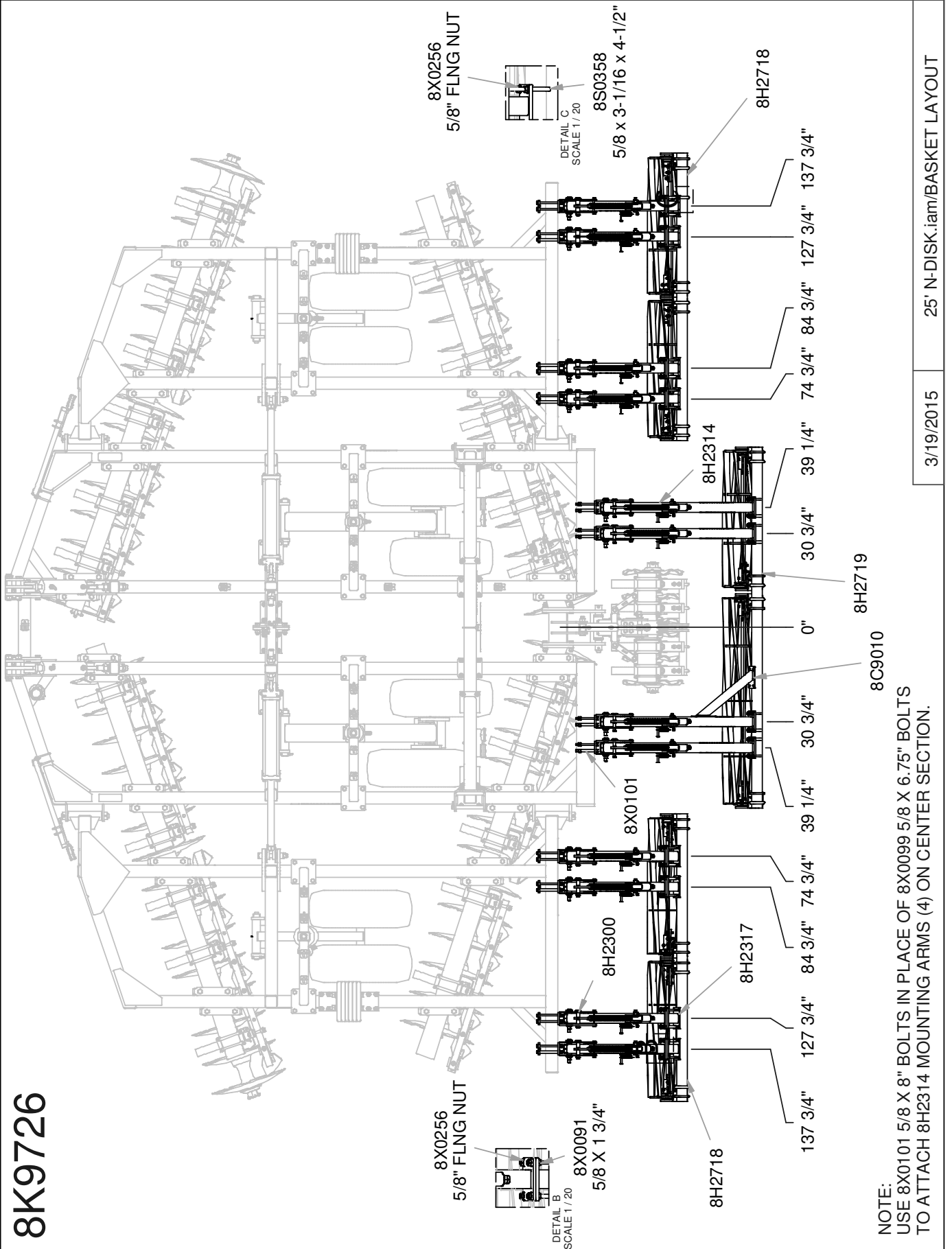

NOTE:
USE 8X0101 5/8 X 8" BOLTS IN PLACE OF 8X0099 5/8 X 6.75" BOLTS
TO ATTACH 8H2314 MOUNTING ARMS (4) ON CENTER SECTION.

3/19/2015

25' N-DISK.iam/BASKET LAYOUT

SECTION 4 - PARTS

8K9730

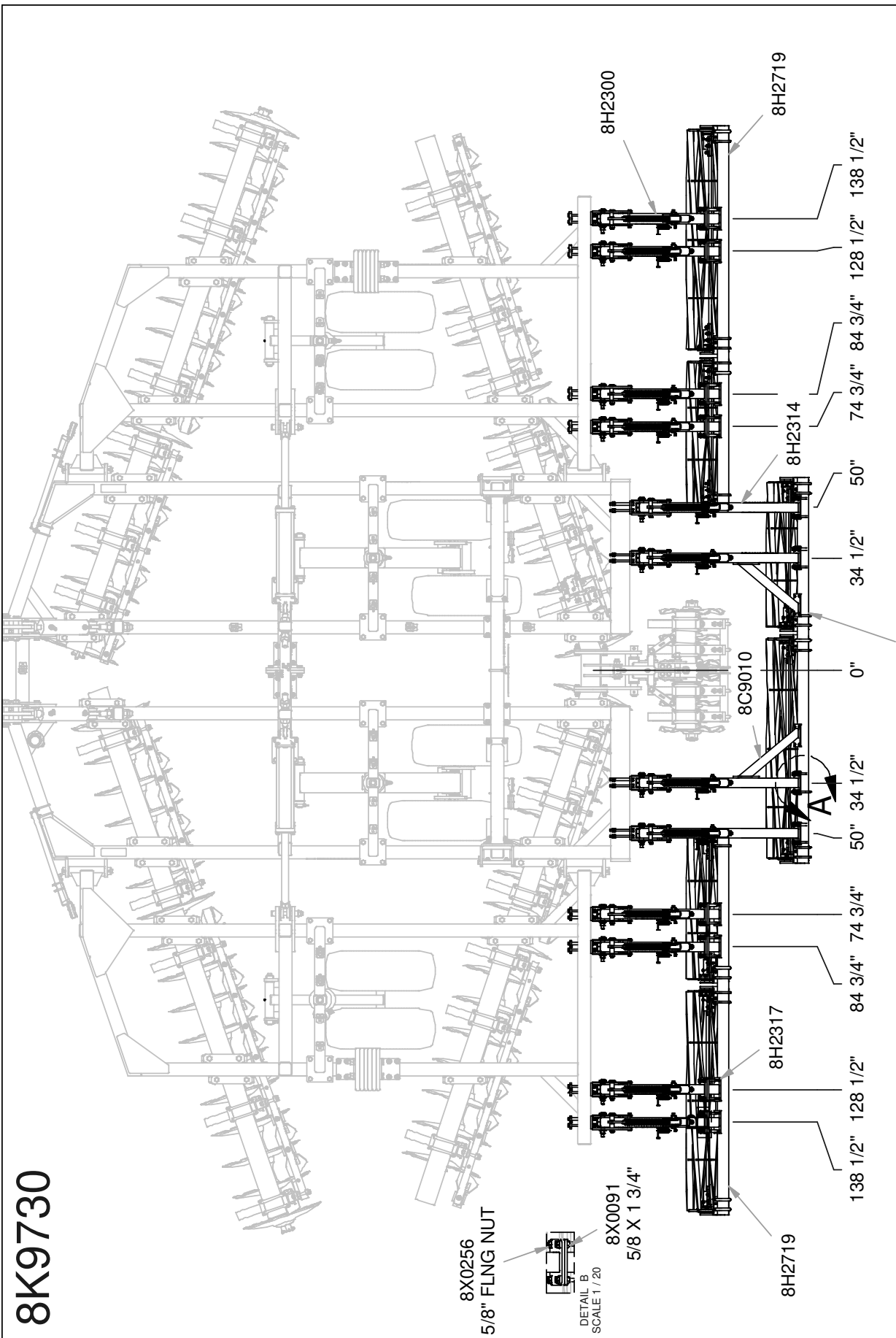

8X0256
5/8" FLNG NUT



8X0091
5/8 X 1 3/4"

8H2719

8H2317

84 3/4"

74 3/4"

50"

34 1/2"

0"

34 1/2"

50"

74 3/4"

84 3/4"

128 1/2"

138 1/2"

8C9010

8H2314

50"

74 3/4"

84 3/4"

128 1/2"

138 1/2"

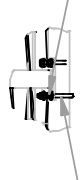

DETAIL A

8X0256
5/8" FLNG NUT

8H2719

NOTE:
USE 8X0101 5/8 X 8" BOLTS IN PLACE OF 8X0099 5/8 X 6.75" BOLTS
TO ATTACH 8H2314 MOUNTING ARMS (2) ON CENTER SECTION.

8S0358

5/8 X 3-1/16 X 4-1/2"

3/19/2015

28.5' N-DISK:iam/BASKET LAYOUT

SECTION 4 - PARTS

8K9718

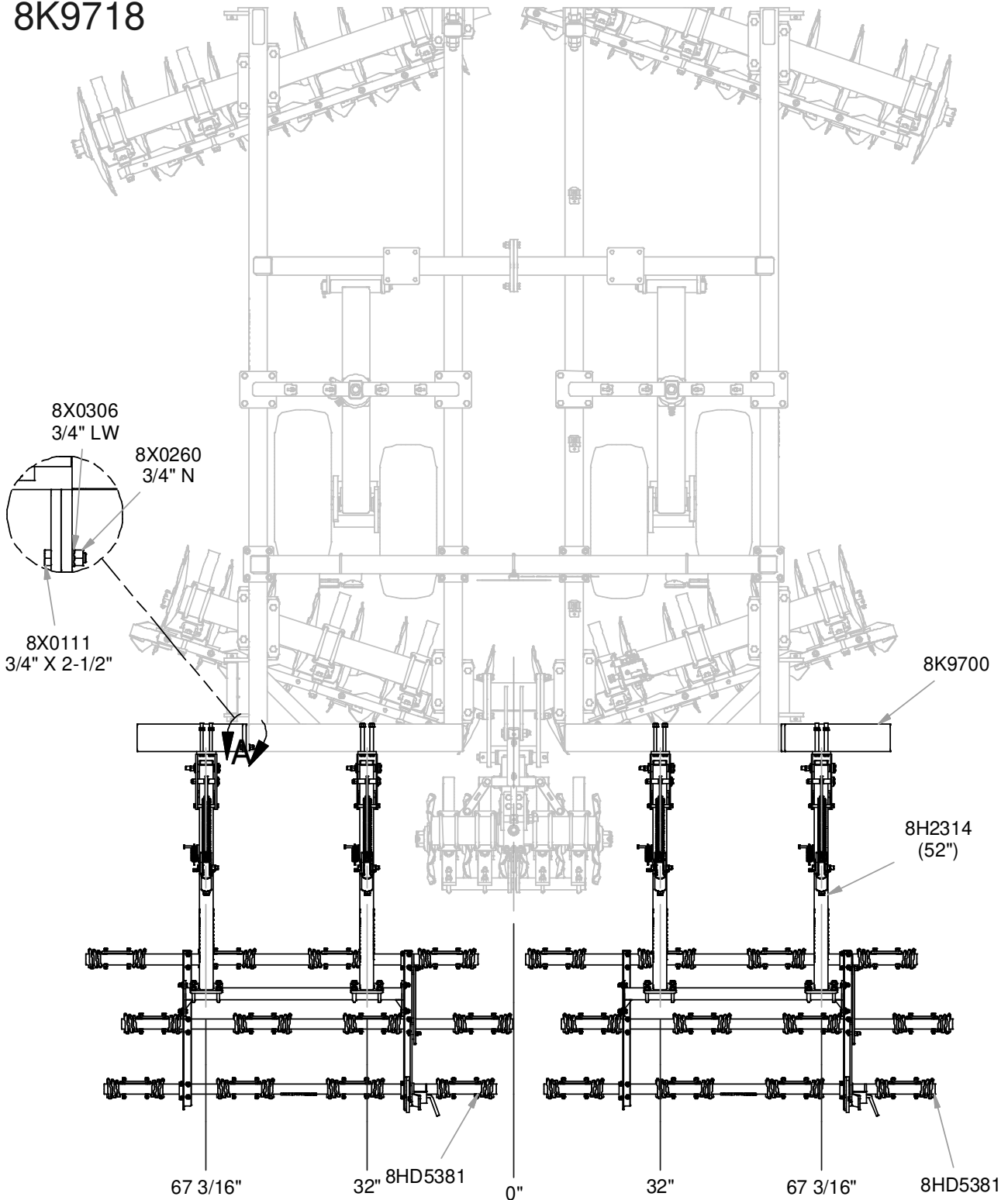

NOTE:
 USE 8X0101 5/8 X 8" BOLTS IN PLACE OF 8X0099
 5/8 X 6.75" BOLTS TO ATTACH 8H2314
 ARMS.

9/3/2014

16' N-DISK.iam/HARROW LAYOUT

SECTION 4 - PARTS

8K9724

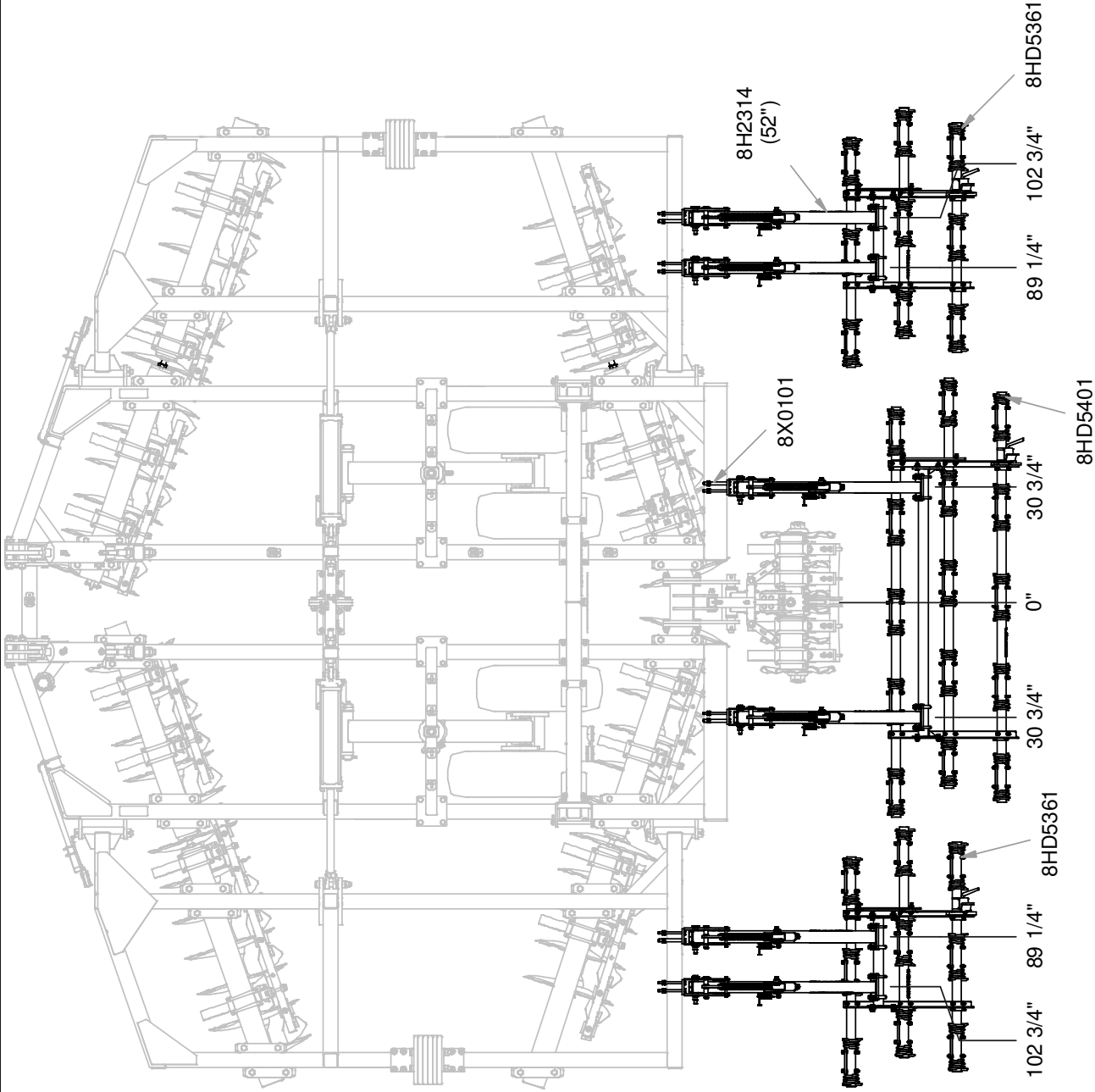

NOTE:

USE 8X0101 5/8 X 8" BOLTS IN PLACE OF 8X0099 5/8 X 6.75" BOLTS TO ATTACH 8H2314 MOUNTING ARMS (2) ON CENTER SECTION.

21' N-DISK.iam/HARROW LAYOUT

9/3/2014

SECTION 4 - PARTS

8K9728

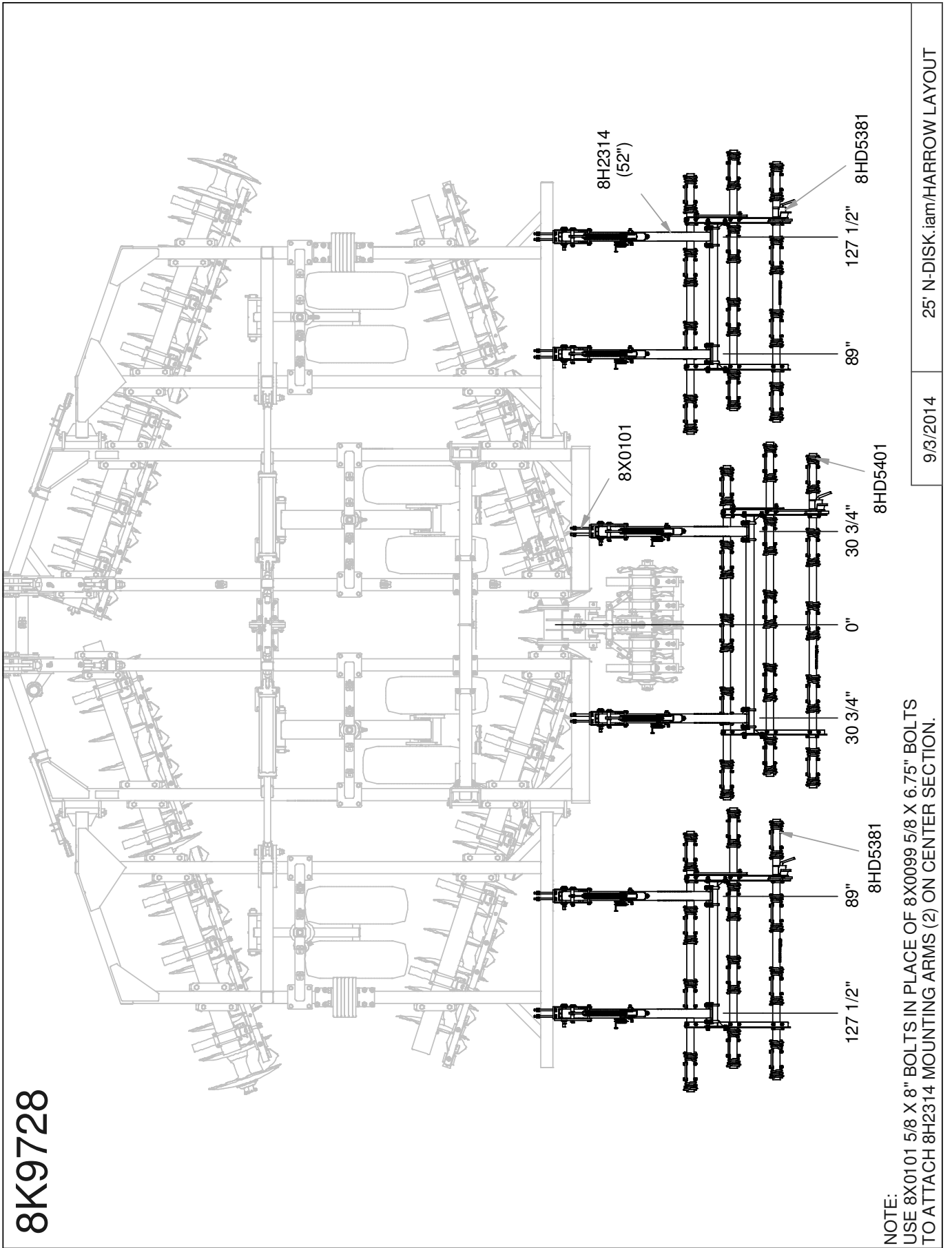

NOTE:
 USE 8X0101 5/8 X 8" BOLTS IN PLACE OF 8X0099 5/8 X 6.75" BOLTS
 TO ATTACH 8H2314 MOUNTING ARMS (2) ON CENTER SECTION.

25' N-DISK.iam/HARROW LAYOUT

9/3/2014

SECTION 4 - PARTS

8K9732

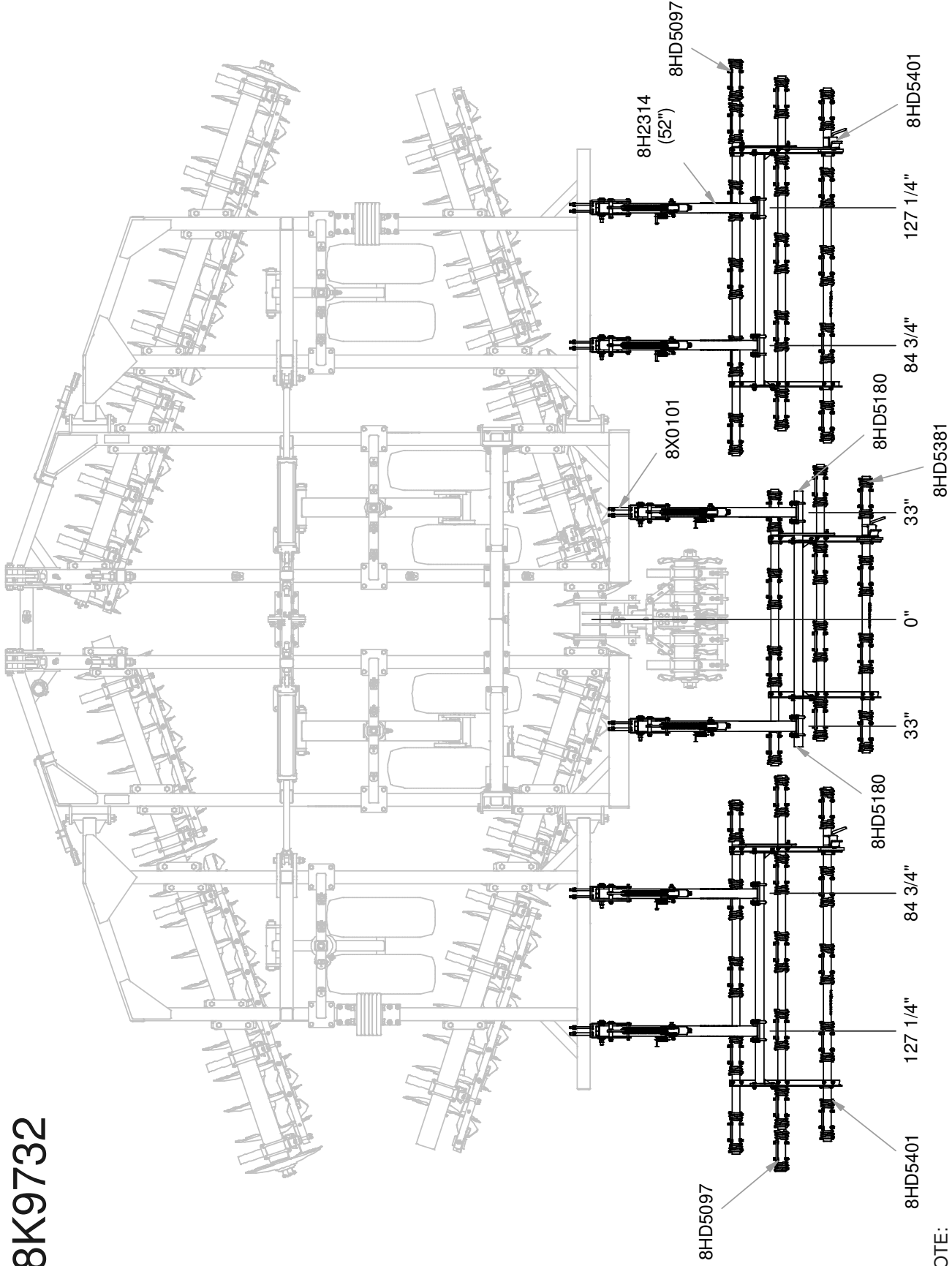

NOTE:

USE 8X0101 5/8 X 8\" BOLTS IN PLACE OF 8X0099 5/8 X 6.75\" BOLTS TO ATTACH 8H2314 MOUNTING ARMS (2) ON CENTER SECTION.

10/23/2014

28.5' N-DISK.iam/HARROW LAYOUT

SECTION 4 - PARTS

PN	QTY
8K5515	8
8K9220	4
8K9230	12
8X0145	4
8X0266	16
8X0280	4
8X0309	4

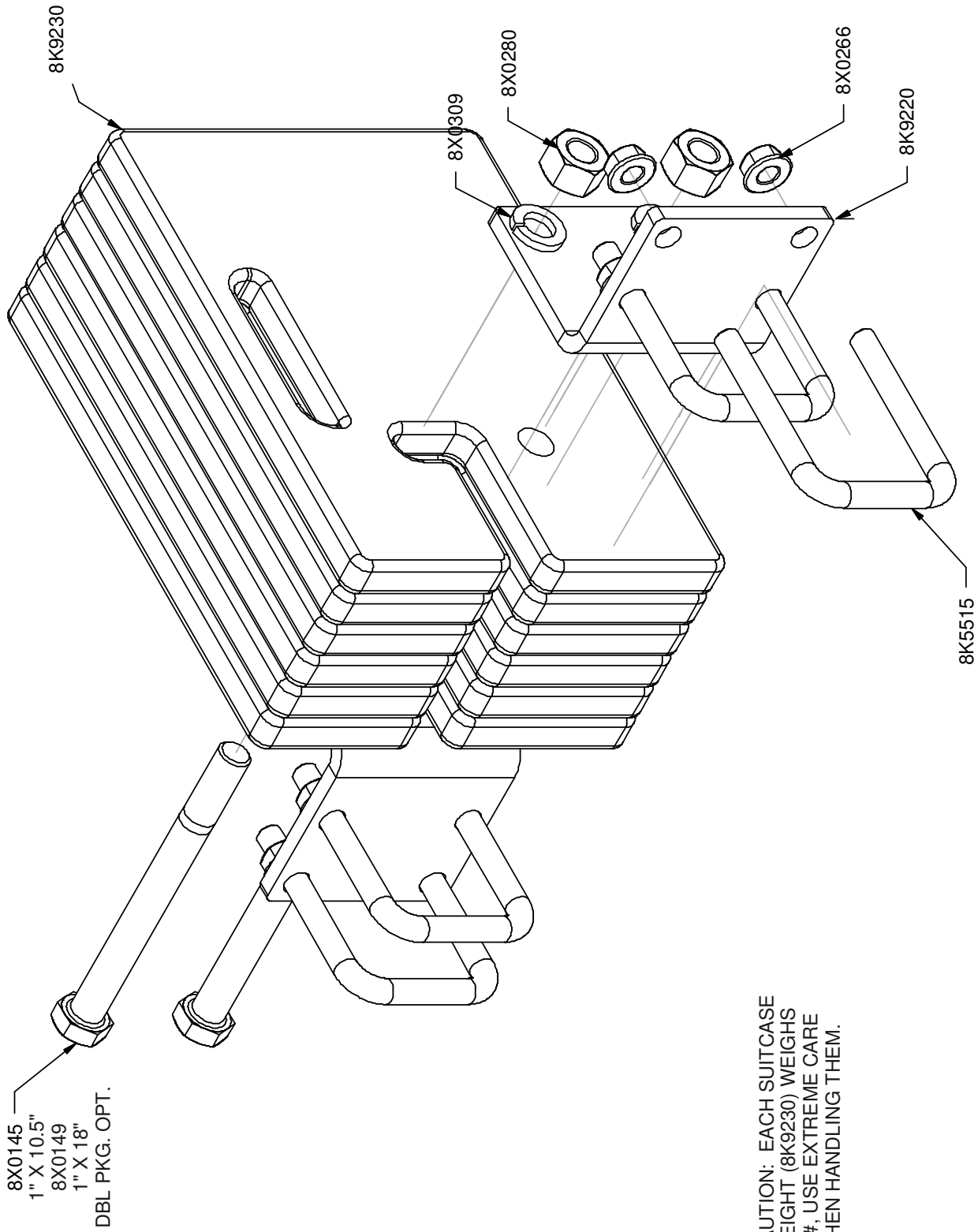

CAUTION: EACH SUITCASE
WEIGHT (8K9230) WEIGHS
70#, USE EXTREME CARE
WHEN HANDLING THEM.

SECTION 4 - PARTS

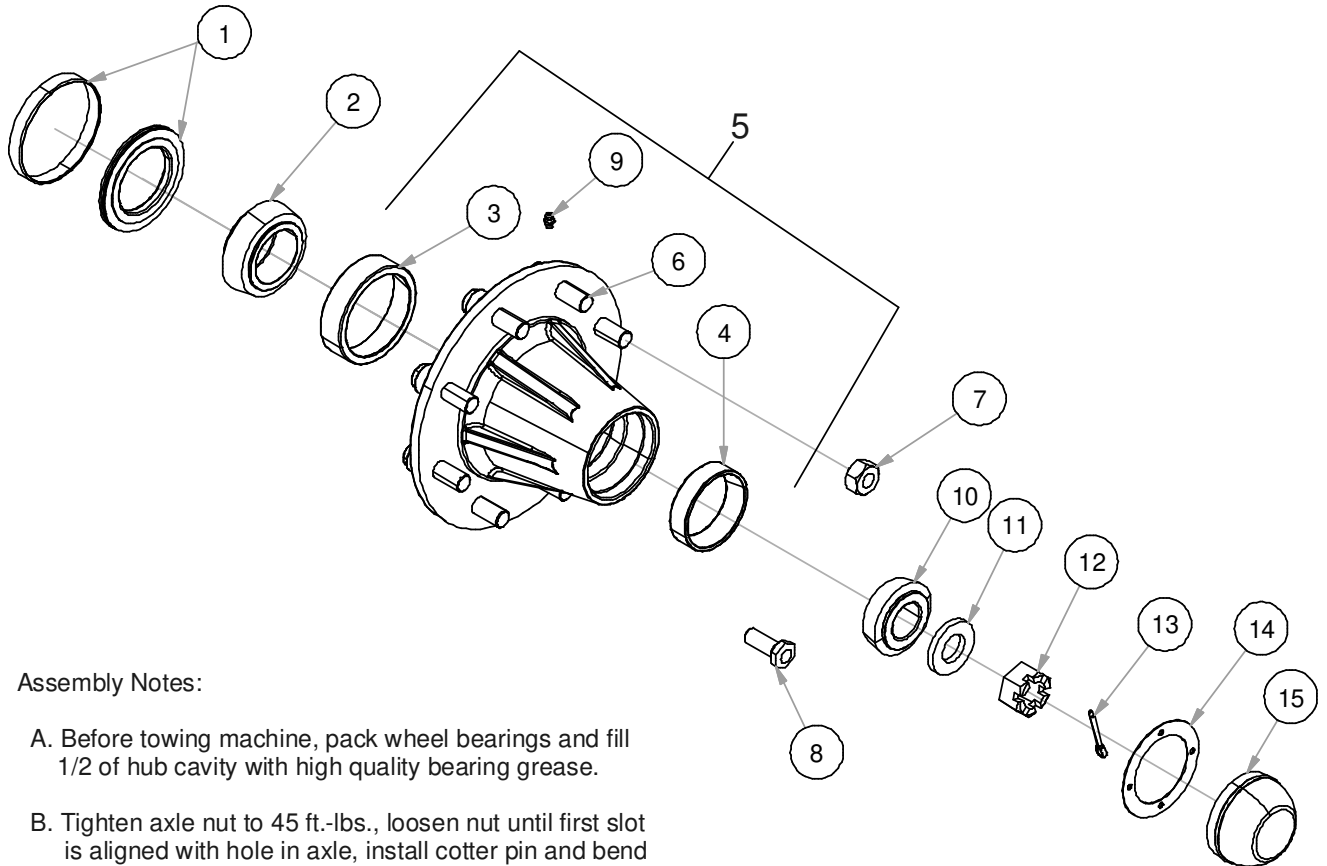

Assembly Notes:

- A. Before towing machine, pack wheel bearings and fill 1/2 of hub cavity with high quality bearing grease.
- B. Tighten axle nut to 45 ft.-lbs., loosen nut until first slot is aligned with hole in axle, install cotter pin and bend to retain.

HUB	1. SEAL	2. INNER BEARING	3. INNER RACE	4. OUTER RACE	5. HUB ASSY	6. WHEEL STUD	7. WHEEL NUT	8. WHEEL BOLT	9. HUB ZERK	10. OUTER BEARING	11. AXLE WASHER	12. AXLE NUT	13. COTTER PIN	14. HUB CAP GASKET	15. HUB CAP	16. HUB CAP BOLT
H211	8G8220	8G8217	8G8230	8G8230	8G8211	N/A	N/A	8D514	8X0708	8G8217	8D5119	8D5112	8X0410	N/A	8G8213	N/A
	SE10	L44643	8L44610	L44610	HDA211			WB10	V4-28NF	L44643	3/4" ID.	3/4"-16	3/16X1"		DC11	
H517	8D5234	8D5217	8D5332	8D5336	8D5210	8D5215	8D5214	N/A	8X0708	8D5117	8S5219	8D5212	8X0415	N/A	8D5213	N/A
	8D5236		LM48548	LM48510	LM67010	H517	WB16		V2-20LNF	V4-28NF	LM67048	7/8" ID.	7/8"-14		3/16X1-1/2"	DCB
	8D5238															
H611	8D5221	8D5317	8D5334	8D5336	8D5311-09	N/A	N/A	8D514	8X0708	8D5117	8D5319	8D5312	8X0415	N/A	8D5213	N/A
	SEB	LM29749	LM29710	LM67010	H611			WB12 D-	V4-28NF	LM67048	1" ID.	1"-14	3/16X1-1/2"		DCB	
H614	8R6922**	8R6917	8R6925	8D5332	8R6911	N/A	N/A	8R6914	8X0708	8D5217	8D5319	8D5312	8X0415	N/A	8R6913	N/A
	SEE GBGI INSTRUCTIONS	LM603049	LM603011	LM48510	H614			WB12	V4-28NF	LM48548	1" ID.	1"-14	3/16X1-1/2"		DC5	
HD812	8K7127***	8K7117	8K7130	8K7132	8K7111	8K7115-9/16**	8K7116-9/16**	N/A	8X0708	8K7118	8D5319	8D5312	8X0415	N/A	8K7113	N/A
	SEAL SE77					8K7122-5/8"	8K7123-5/8"		V4-28NF	LM2790	1" ID.	1"-14	3/16X1-1/2"		DC17	
	8K7128***	LM3780	LM3720	LM2720	HD812	WB41	WB40									WB46
HD817	8K7344	8K7342	8K7346	8K7347	8K7340	8K7122-5/8"	8K7123-5/8"	N/A	8X0708	8K7343	8X0328	8D5314	8X0414	N/A	8K7341	N/A
	SE42	LM387AS	382A	LM501310	HD817	WB46	WB18		V4-28NF	LM501349	1312 ID.	11/4"-12	11/4X2"		DC26	
H1010 LT	8K7220	8K7217	8K7230	8K7232	8K7211	8K7215	8K7216	N/A	8X0708	8K7218	8X0328	8D5314	8X0414	8K7212	8K7213	8K7214
	SE48	39585	39520	453A	H1010-9	WB51	WB52		V4-28NF	460	1312 ID.	11/4"-12	11/4X2"	SE49	DC27	WB53
H1010 HVY	8K7221	8K7219	8K7231	8K7232	8K7210	8K7215	8K7216	N/A	8X0708	8K7218	8X0328	8D5314	8X0414	8K7212	8K7213	8K7214
	SE67	33275	33462	453A	HD10-11	WB51	WB52		V4-28NF	460	1312 ID.	11/4"-12	11/4X2"	SE49	DC27	WB53
H1020	8K7320	8K7317	8K7330	8K7332	8K7209	8K7215	8K7216	N/A	8X0708	8K7318	8X0366	8D5318	8X0418	8K7312	8K7313	8K7214
	SE55	HM218248	HM218210	HM212010	HDA1020	WB51	WB52		V4-28NF	HM212049	2.03" ID	2" - 12WB65	5/16 X 2-1/2"	SE59	DC28	WB53

**Pre 2000

***GBGI (Not Shown), 8R6921 Triple Lip (Shown)

***Pre 2006 8K7120(SE17)

CD2\MANUALS\10 2-26 HUB-AXLE COMPONENTS

LAST REVISION: 1/17/2011

8/13/2014

8K1105S.iam/HUB&AXLE ASSY

SECTION 4 - PARTS

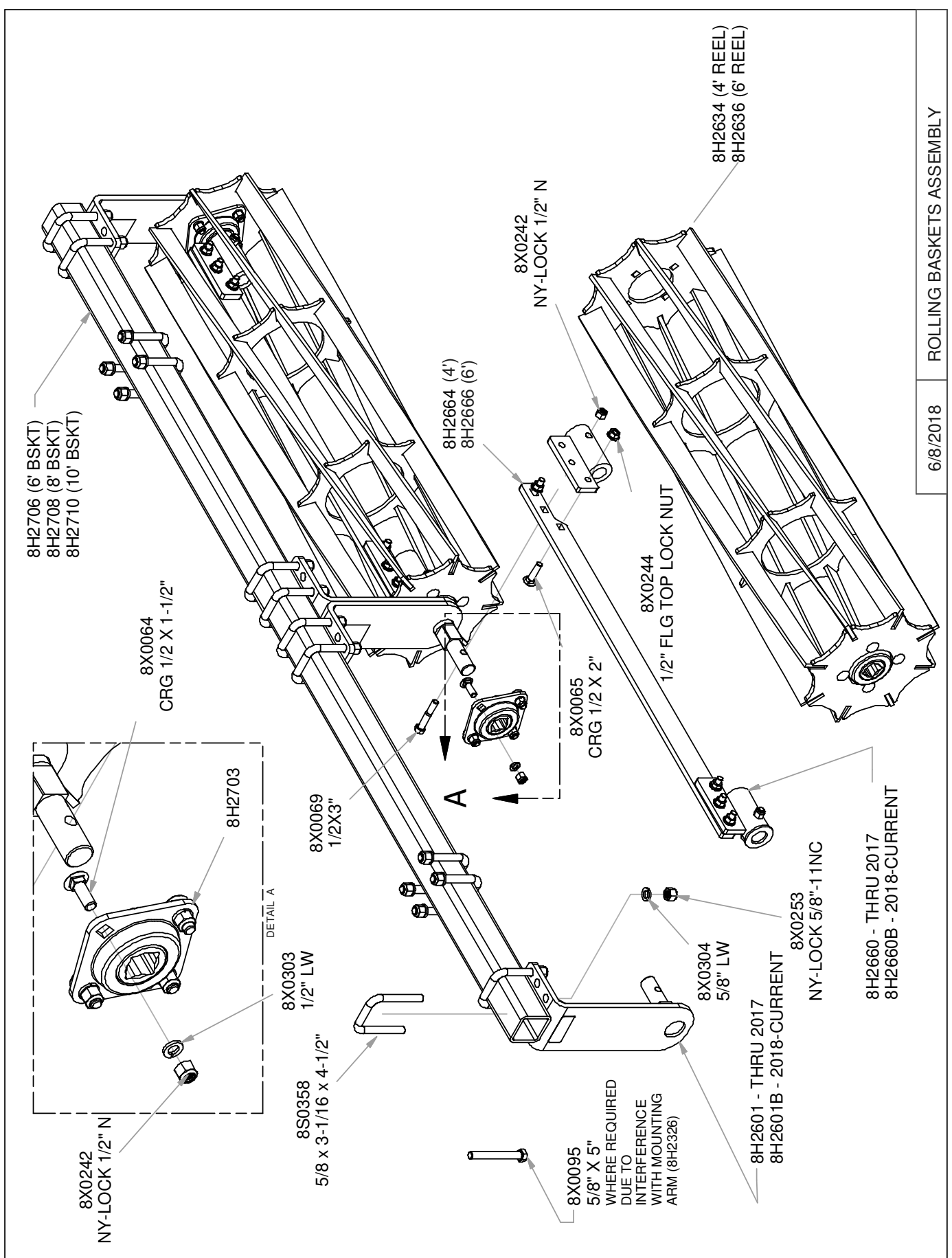

6/8/2018 ROLLING BASKETS ASSEMBLY

SUMMERS MFG. CO., INC.

3/23/15

INSTALLATION AND OPERATION INSTRUCTIONS FOR 8K1850

HUBODOMETER W/ HOUSING FOR SUMMERS DIAMOND DISK AND 2510 DT

Attach HUB ODOMETER to gang nut as shown in photos with 3/8" x 4-1/2" bolt, flat washers and lock nut. To prevent loosening, rotate gang to insure that bracket is on center and spot weld at locations shown.

Position Hubodometer on inside of rear center gang. DO NOT LOCATE HUBODOMETER BENEATH IMPLEMENT WING HINGE OR AT WIDEST POINT OF MACHINE. Hub Odometer will be damaged if installed in these locations.

The Hub Odometer is calibrated at 359 revolutions per acre. Refer to chart below for conversion for your implement.

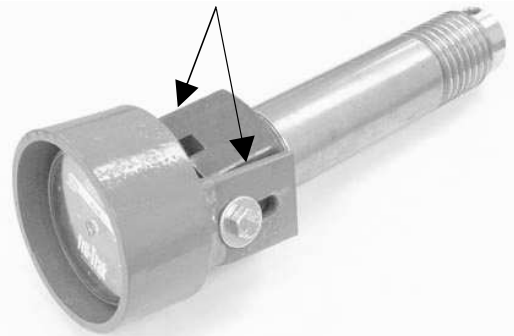

MACHINE	CONVERSION FACTOR
Diamond Disk Width	Multiply by ___ for Acres Covered
16'	.90
18 1/2'	1.04
21'	1.19
21 1/2'	1.22
24 1/2'	1.37
25'	1.40
28'	1.58
28 1/2'	1.61
32 1/2'	1.82
38 1/2'	2.16
44 1/2'	2.49
47'	2.63
DT9530 Width	
16'	.86
18 1/2'	1.00
21'	1.14
21 1/2'	1.17
24 1/2'	1.32
25'	1.35
28'	1.52
28 1/2'	1.55
32 1/2'	1.75
38 1/2'	2.08
44 1/2'	2.39
47'	2.53

SECTION 5 - PART NUMBERS AND DESCRIPTIONS

Stock Code	Description	Stock Code	Description
7K2055	STL 1/2 X 2 X 4.25" 11-	8J6010	3/4"-16 ORB X #6 JIC(M)90*ADP
7K2060	STL 5/8 SCRAPER BACKPLATE 11-	8J6020	3/4"-16 ORB X #10 JIC(M)90*ADP
7L2150	STL 1/2 X 7-1/2"OD X 2-9/16"ID	8J6030	7/8"-14 ORB X #10 JIC(M)90*ADP
7P8530	ROUND CR 2-1/2- 22-1/4" 07-	8J7040	THERMAL RELIEF MANIFLD 4000PSI
8A1004	CLAMP HOSE 5" #72	8J7216	#6JIC(M)X6JIC(F)1/16"RSTR BLKZ
8A1155	U-BOLT 3/8 X 6-1/16 X 5" SQ	8K0050	MNT BRKT ADJ DPRSS MANFLD 12-
8A1156	U-BOLT 3/8 X 4-1/16 X 5" SQ	8K0150	DTGANG 10 BLADE LEFT FRNT WING
8A1954	TUBING GAGE LINE 1/4"OD PER FT	8K0152	DTGANG 10 BLADE RGHT FRNT WING
8A4048	NYLON TIE .18 X 11"	8K0750	DTGANG 7 BLADE LEFT FRONT CNTR
8A4050	NYLON TIE .30 X 8-7/8"	8K0850	DTGANG 8 BLADE RGHT FRONT CNT
8A4052	NYLON TIE .30 X 15.25"	8K0852	DTGANG 8 BLADE LEFT REAR WING
8C1718	U-BOLT 1/2 X 2-5/8 X 2-5/8" SQ	8K0860	DTGANG 8 BLADE LEFT REAR CNTR
8C9010	BRACE MNTNG ARM RLNGATCH 09-	8K0862	DTGANG 8 BLADE RGHT REAR CNTR
8CC6018	PARALLEL LINK W/ HLS N-DSK 13-	8K0865	DTGANG 8 BLADE RGHT REAR WING
8CC6020	PARALLEL LINK W/O RCKSHFT 10-	8K1075	SPLICE TUBE REAR W/PIVOT 11-
8CC6035	WASHER 2.5X4X 1.281"ID 11-	8K1105S	HUB&AXLE ASSY HD812 (2"RCVR)
8D0340	U-BOLT 3/4 X 4-1/16 X 7-3/4"SQ	8K1134N	LIFTARM 32.5' WING & NRRW 07-
8D0350	U-BOLT 3/4 X 4-1/16 X 10" SQ	8K1152	LIFTARM18.5-32.5 REARCNTNR98-
8D2470	SAFETY CHAIN 30400# 7/16" X 5'	8K1410	HITCH NRRW DSK 12-
8D3212	MALE TIP 3/4"-16 ORB ISO	8K1415	CNTR FRAME NRRW DSK-LEFT 12-
8D8490	PIONEER/ISO TIP HLDR BNT 97-	8K1417	CNTR FRAME NRRW DSK-RGHT 12-
8D8500	HYD HOSE HOLDER PNTD BLK 91-	8K1420	WING FRAME NRRW DSK-LEFT 12-
8D8522	JACK 5000# TOP CRANK 15"LIFT	8K1422	WING FRAME NRRW DSK-RGHT 12-
8D9108	ROLL PIN 1/4 X 2" ZINC	8K1425	CROSSTUBE TRNSMNT NRRW DSK12-
8D9110	HAIRPIN CLIP LARGE (1"CYL PIN)	8K1430	SPLICE TUBE FRONT NRRW DSK12-
8D9524	HYD CYL 5 X 24" 3000PSI 09-	8K1435	A-FRAME NRRW DSK 12-
8G2282	NYLON TIE .187 X 7-1/2" RED	8K1440	WINGLOCK NRRW DSK 12-
8G2284	NYLON TIE .187 X 7-1/2" YELLOW	8K1445	TUBE 1.75 X1.268ID-2.25" 12-
8G2285	NYLON TIE .187 X 7-1/2" GREEN	8K1449	BOLT-ON LINK ARM PIVOT-R 13-
8H2600	RLLNG BSKT ENDPLATE 09-12	8K1451	BOLT-ON LINK ARM PIVOT-L 13-
8H2601	ENDPLATE RLNGBSKT 4SCRPR 12-	8K1452	SIDEPLT CSTR CYLATCH N-DSK13-
8H2601B	ENDPLATE RLNGBSKT 4SCRPR 17-	8K1470	CYLATCH CASTR FRNT N-DSK 12-
8H2660	RLLING BSKT SCRAPER MNT 12-	8K1475	CASTER ARM N-DISK -L 12-
8H2660B	RLLING BSKT SCRAPER MNT 17-	8K1477	CASTER ARM N-DISK -R 12-
8H2314	MNTG ARM ASSY 52" M94-M108	8K1485	WING LIFT CYL ATCH NRW DSK12-
8H2718	RLLNG BSKT ASSY 8FT	8K1500	CASTER MNT NRRW-DISK 13-
8H2719	RLLNG BSKT ASSY 10FT	8K1615	PIN 3/4X 10-1/2" SAFETYLCK 13-
8HD5097	M104 1 TINE EXT OPT PAIR 03-	8K1640	PIN 1-1/2 X 10-5/8" HITCH 84-
8HD5180	EXT BRCKT M94-108 2ND ARM 15"	8K1660	PIN 1-1/2 X 15-1/2" HARDEND84-
8HD5381	8' 3BR M104SECT ASSY QADJ00-	8K1660	PIN 1-1/2 X 15-1/2" HARDEND84-
8HD5401	10'3BR M104SECT ASSY QADJ00-	8K1755	EYEBOLT 1.5"DIA X1.26EYE YZ 12-
8J1000	SPRING SHNK W/BRG&MNTFLT 00-	8K1900	SEAL GBGI V WALKNG TANDM 01-
8J1021N	CLTR BLADE 8X1.75W NOTCH.26X22	8K1920	RETAINING RING 2-7/8" INV 00-
8J1022H	CLTR BLADE 13WAVE .256X22" 04-	8K2104	SPRING SHNK W/BEARNG ASSY DSK
8J3005	SPACER 2.02IDX2.63OD-2.63" 13-	8K2130	GANG ROD 2" DIA X 57"
8J3010	CAST SPOOL 10" FULL CLTR 00-	8K2170	GANG ROD 2" DIA X 97"
8J5110	#10 JIC(M) X #10 JIC(M) UNION	8K3002	WRENCH GANG 3-1/8" HEX BLCK00-
8J5200	#10 JIC(F) X #6 JIC(M)HEX BUSH	8K3100	GANG MNT TUBE LEFT FRNT 98.5"
8J5300	TEE #6 JIC (MALE) 3X	8K4000	SPOOL FULL DISK DUCTIL MACHIND
8J5510	3/4"-16 ORB X #6 JIC(M) STR	8K4010	SPOOL HALF SHRT 2.63" DISK 94-
8J5520	3/4"-16 ORB X #10 JIC(M) STR	8K4019	SPOOL HALF 4.8" FLAT CLTR 00-
8J5550	1-1/16" - 12ORB X#10JIC(M)STR	8K4020	SPOOL HALF LONG 4.9" DISK 94-
8J5620	3/4"-16 ORB X #6 JIC(F-SW)STR	8K4199	CAST CLAMP GANG MNT W/PEG RAW
8J5700	#6 JIC(F-SW) X #6 JIC(M)90*ADP	8K4209	CAST CLAMP GANG MOUNT RAW
8J5710	#10 JIC(F-SW)X#10 JIC(M)90*ADP	8K4299	CAST CLAMP SCRAPER MNT RAW
8J6000	9/16"-18 ORB X #6 JIC(M)90*ADP	8K4404	STL 5/16" 2510 SCRAPER IN RAW

SECTION 5 - PART NUMBERS AND DESCRIPTIONS

Stock Code	Description	Stock Code	Description
8K4406	STL 5/16" 2510 SCRAPR OUT RAW	8T1060	HYD CYL 6 X10 W/STRK CNTRL 96-
8K4409	STL 3/16" SCRAPR PLATE DSK RAW	8T2990	HYD HOSE CLAMP MTL/RUB BACK
8K4423	FILLER FLAT 5/8 X 2.5- 3" 08-	8T3300	BOLT PIVOT CHSLTRP&WNLFT YZ
8K4429	ARM 5/8 X 2.5-15.375"HR1044RAW	8T3620	PIN 1-1/2 X 12-1/2" HRDND&ZINC
8K4449	BRCKT ADJ OFFSET SCRAPER 99-	8T4132	WLKNG TNDM 7.5"C-C 2" ID 98-
8K5025N	BLADE DSK1/4X25" 2HL NTCH LOWC	8T4350	TRNS LCK W/UHMW10.5"(2.4RD)96-
8K5200	WASHER GANG BOLT 2.03" ID	8X0000	BOLT 1/4-20X3/4" FLLTHD GR5 YZ
8K5200	WASHER GANG BOLT 2.03" ID	8X0015	BOLT 3/8-16NC X 3-3/4" GR5 YZ
8K5200	WASHER GANG BOLT 2.03" ID	8X0021	BOLT 5/16-18NC X 3/4" GR5 YZ
8K5515	U-BOLT 3/4 X 4-1/16 X 6" SQ	8X0021A	BOLT 5/16-18NC X 1" GR5 YZ
8K5520	U-BOLT 3/4 X 6-1/8 X 7-1/2" SQ	8X0044	BOLT 7/16-14NC X 3-1/2"GR5 YZ
8K6313	HYD CYL 2.25X6" 1.25"RD 11-	8X0063	BOLT 1/2-13NC X 1-1/2" GR5 YZ
8K7042	12.5L X 15 LRF ON 15X10X8 WHL	8X0072	BOLT 1/2-13NC X 3-3/4" GR5 YZ
8K8000	STL 7K2045 3/8X3.5 PNTDLGHT09-	8X0101	BOLT 5/8-11NC X 8" GR5 YZ
8K8010	TUBE LGHT BRCKT 1.5SQ PNTD 00-	8X0110	BOLT 3/4-10NC X 1-1/4" GR5 YZ
8K8020	STL 12GA MNTNG BRCKT LIGHT 00-	8X0111	BOLT 3/4-10NC X 2-1/2" GR5 YZ
8K8030A	MODULE AG ENHNCDW/BRAKE6PIN08-	8X0113	BOLT 3/4-10NC X 5" GR5 YZ
8K8067	DUST CAP FOR 7PIN CONNECT00-	8X0114	BOLT 3/4-10NC X 3" GR5 YZ
8K8069	MAIN HRNSS 7PN 20' W/BRAKE 17-	8X0121	BOLT 3/4-10NC X 6-1/2" GR5 YZ
8K8071	MAIN HRNSS 7PN 26' W/BRAKE 09-	8X0123	BOLT 3/4-10NC X 5-1/2" GR5 YZ
8K8075A	EXT HRNSS NONDRAWBR DTSCH 07-	8X0133	BOLT 7/8-9NC X 3" GR5 YZ
8K8090A	LIGHT AMBER 2WIRE DEUTSCH 07-	8X0138	BOLT 1-8NC X 5-1/2" GR5 YZ
8K8095A	LIGHT RED 3WIRE DEUTSCH 07-	8X0139	BOLT 1-8NC X 3" GR5 YZ
8K8104	EXT HRNSS 13'2WIRE DTSCH 07-	8X0140	BOLT 1-8NCX7" W/1.5"THDGR5 YZ
8K8200	BRCKT SMV ATTCH 4-8"FRAME98-	8X0143	BOLT 1-8NC X 5" GR5 YZ
8K9106	PIN 1-1/4 X 4-3/8" HRDND 1/4HL	8X0146	BOLT 1-8NC X 8-1/2" GR5 YZ
8K9250	900#WGHT PKG W/HRDWR DSK/CLTR	8X0202	NUT 3/8"-16NC NY-LOCK GR2 YZ
8L0246	BUSHING 2.875X2.5ID- 3" 97-	8X0203	NUT 3/8"-16NC SERFLANG GR2 YZ
8L0252	WASHER 1.28"IDX4.5ODX 1/4" YZ	8X0211	NUT 5/16"-18NC SERFLANG GR2 YZ
8L0258	U-BOLT 5/16 X 1-1/2 X 2-1/2"SQ	8X0223	NUT 1/4"-20NC SERFLANG GR2 YZ
8L0320	PLATE 2PNT&LR CASTER WEAR 96-	8X0234	NUT 7/16"-14NC NY-LOCK GR2 YZ
8N3028	3/8X 28"HYD HOSE #6FJX3000PSI	8X0242	NUT 1/2"-13NC NY-LOCK GR2 YZ
8N3035	3/8X 35"HYD HOSE #6FJX3000PSI	8X0246	NUT 1/2"-13NC SERFLANG GR2 YZ
8N3048	3/8X 48"HYD HOSE #6FJX3000PSI	8X0256	NUT 5/8"-11NC SERFLANG GR2 YZ
8N3060	3/8X 60"HYD HOSE #6FJX3000PSI	8X0260	NUT 3/4"-10NC HEX GR2 YZ
8N3124	3/8X 124"HYD HOSE #6FJX3000PSI	8X0261	NUT 3/4"-10NC NY-LOCK GR2 YZ
8N3150	3/8X 150"HYD HOSE #6FJX3000PSI	8X0265	NUT 3/4"-10NC CNTRLOCK GR2 YZ
8N3228	3/8X 228"HYD HOSE #6FJX3000PSI	8X0270	NUT 7/8"-9NC CNTRLOCK GR2 YZ
8N3252	3/8X 252"HYD HOSE #6FJX3000PSI	8X0280	NUT 1"-8NC HEX GR2 YZ
8N3312	3/8X 312"HYD HOSE #6FJX3000PSI	8X0281	NUT 1"-8NC NY-LOCK GR2 YZ
8N3390	3/8X 390"HYD HOSE #6FJX3000PSI	8X0282	NUT 1"-14TPI TOPLOCK GR B Z
8N4160	1/2X 160"HYD HOSE#10FJX3000PSI	8X0284	NUT 1-1/4"-7NC HEX GR2 YZ
8N6060	3/4X 60"HYD HOSE#10FJX3000PSI	8X0285	NUT 1-1/2"-6NC HEX GR2 YZ
8N6354	3/4X 354"HYD HOSE#10FJX3000PSI	8X0286	NUT 1-1/2"-6NC JAM GR2 YZ
8N7000	ADJ DOWN PRESSURE MANIFLD 12-	8X0292	NUT 2"-4.5 HVY HEXSLOT GR2 PLN
8S0358	U-BOLT 5/8 X 3-1/16 X 4-1/2"SQ	8X0300	LOCKWASHER 5/16" YLW ZNC
8S1120	SIGN SLOW MOVING VEHICLE(SMV)	8X0306	LOCKWASHER 3/4" YLW ZNC
8S1124	MOUNTING SOCKET SMV SIGN	8X0307	LOCKWASHER 7/8" YLW ZNC
8S1126	MNT SPADE W/HRDWR SMV SIGN	8X0309	LOCKWASHER 1" YLW ZNC
8S2990	HYD HOSE CLAMP-LARGE-NYLON	8X0311	LOCKWASHER 1-1/4" YLW ZNC
8S3095	CAPLUG FITS ISO HYD COUPLR 08-	8X0316	WASHER 1" SAE FLAT YZ
8T1037	HYD CYL 3.75 X 10"R3755M-10BP	8X0318	WASHER 3/4"(13/16"ID)FLAT YZ
8T1040B	HYD CYL 4.0 X 10" FOR 5PLX 99-	8X0320	WASHER 3/8"(7/16" ID)FLAT YZ
8T1045	HYD CYL 4.5 X 10" REPHASE 96-	8X0366	WASHER 2.03IDX2-7/8ODX 1/4"PLN
8T1050	HYD CYL 5 X 10" REPHASE 96-	8X0402	HAIRPIN CLIP 1/8 X 2-9/16"
8T1055	HYD CYL 5.5 X 10" REPHASE 96-	8X0440	CLEVIS PIN 5/8 X 3-7/8" YZ

SECTION 5 - PART NUMBERS AND DESCRIPTIONS

Stock Code	Description	Stock Code	Description
8X1120	CRG 3/8-16NC X 2" GR2 ZN	8Z0344	DECAL WING DANGER
8X1140	CRG 3/8-16NC X 4" GR2 ZN	8Z0346	DECAL ELECTROCUTION-TILLAGE
8Z0075	DECAL TRNSPRT LCK WARNING TILL	8Z0350	DECAL GREASE GANG BEARNG 04-
8Z0087	DECAL "WARNING" PINCH POINT03-	8Z0800	REFLECTOR AMBER ADHSVBCK98-
8Z0100	DECAL MADE IN USA	8Z0805	REFLCTR REDORANGE ADHSVBK99-
8Z0101	DECAL "SUMMERS" M94/04/06 2.25X9	8Z0810	REFLECTOR RED ADHSV-BACK 98-
8Z0204	DECAL 5.5" SUMMERS 14-	8Z1000	MANUAL-PAK 3DIA X 11.75" 09-
8Z0276	DECAL GENERAL CAUTION 91-	8Z2255	DECAL DK9630 ID 16-28.5' N-DISK
8Z0340	DECAL REPHASING CYLINDERS	8Z2290	DECAL DT9530 ID 16-28.5' N-DT
8Z0342	DECAL INSTALL CYLINDER LOCKS		

SECTION 5 - PART NUMBERS AND DESCRIPTIONS

History of Summers Manufacturing Co., Inc.

- 1965 – Summers Manufacturing is founded by Harley Summers, who purchases patent rights for Goebel truck and pickup hoists from the Goebel Brothers of Lehr, ND. These hoists, produced in Harley Summers' blacksmith shop the first year, were distributed nationwide by a Cincinnati, Ohio, dealer. With increasing sales, the company soon outgrows the small shop. Summers wins the Herman harrow contract, beginning the company's Herman culti-harrow line. Summers builds a 7,200 square-foot factory in Maddock to meet the demand for truck and pickup hoists, as well as Herman harrows.
- 1969 – Firm incorporates and becomes officially known as Summers Manufacturing Company, Inc.
- 1970 – Summers purchases rights to manufacture/market the Herman Harrow.
- 1973 – Company builds new 20,000 square-foot plant and offices in Maddock, adding a 20,000 square-foot assembly plant in the fall of 1975 (completed in January 1976), bringing total square footage of Maddock factories to 47,000.
- 1977 – Summers introduces the Agri-sprayer, used in conjunction with the Herman culti-harrow to incorporate herbicides and liquid fertilizer.
- 1980 – Company purchases manufacturing and distributing rights to Crown rockpickers from Crown Manufacturers of Regina, Saskatchewan. This forces another expansion project – a 26,000 square foot factory on a 24 acre site in Devils Lake, ND Industrial Park.
- 1981 – Company establishes a branch facility in Regina, Saskatchewan.
- 1982 – Devils Lake plant begins operations in January, manufacturing supersprayers and rockpickers. The Maddock factory begins producing the Superweeder, a combination cultivator and harrow.
- 1983 – Summers buys manufacturing and distributing rights to the Fargo Field Sprayer line from Mid America Steel (formerly Fargo Foundry), Fargo. This field sprayer line is manufactured at the Devils Lake plant. Harley Summers is selected North Dakota's small-businessman of the year by the Small Business Administration.
- 1984 – Herman Diamond Disk, a disk harrow made in a diamond shape to reduce blade breakage from rocks, comes off the assembly line.
- 1985 – Summers signs a contract with Melroe Company of Bismarck to obtain exclusive manufacturing rights to the Melroe harrow line.
- 1989 – Summers purchases TorMaster Company of Hordean, Manitoba, giving the company a line of rolling packer equipment, comprised of harrow packers and hydraulic fold coil packers.
- 1992 – A new engineering office/parts department is added to the Devils Lake factory.
- 1993 – Company adds two new products: a pickup-mounted sprayer with booms of 80 and 90 feet, and the Summers Superharrow, an extra-heavy-duty residue-management tool designed for the minimum and no-till farmer.
- 1994 – a 50 by 125 foot addition to the Maddock factory is completed. Construction begins on a 24,576 square-foot addition to the Devils Lake factory, which enables the company to increase production of truck-mounted and pull-type supersprayers and rockpickers.
- 1996 – 1500 square foot office area added to the Maddock plant. Company introduces Chisel Plow with floating hitch and 700# trip assembly.
- 1997 – 16,800 square foot warehouse in Maddock purchased from local business.
- 1999 - Company introduces the Ultimate suspended boom trailer sprayer with hydraulic folding booms. Additional sizes added to the Chisel Plow line, now ranging from 28' to 54'.
- 2000 - Company introduces the Supercoulter, the innovative solution for excessive field residue management on no-till, minimum-till, and conventional-till farming operations.
- 2001 - Cold storage building completed at Devils Lake. Company extends boom lengths up to 110 feet on the Ultimate Supersprayer.
- 2002 - Company adds a warehouse and service man in Aberdeen, SD.
- 2003 - Company introduces the Ultimate NT Supersprayer featuring a bolt on axle for easier adjustment, and a new family of tanks that feature a drainable sump and a common width dimension.
- 2004 - A 124 ft. x 310 ft. addition is added onto the current Devils Lake plant.
- 2005 - The Summers Superroller is added to the "Field Tested Tough" product line. Additional sizes of 56', 58' and 60' are added to the Superchisel line. Ultimate-Ultra NT Supersprayer introduced featuring 120' & 133' booms.
- 2006 - The Summers Coulter-Chisel, Rolling Choppers and 30' Superroller were included in product line.
- 2007 - 62' & 84' 5 Section Landrollers and a 20' Coulter-Chisel were introduced.
- 2008 - Disk-Chisels, ranging from 16' to 40' widths, are added to product line.
- 2009 – M105 and M108 Mounted Harrows added to selection of Mounted Attachments. SuperHarrow 2650, 50' SuperCoulter, Hydraulic Fold Rolling Chopper and 36" diameter Landrollers introduced.
- 2010 – Rolling Basket and 47' Diamond Disk added to product line. A 124 ft. x 310 ft. addition to Devils Lake factory built for a state of the art paint system.
- 2011 – Additional Supercoulter sizes were added along with larger tires for tillage implements. Ultimate and Ultra Supersprayers received an additional tank size of 1650 gallons. Front Caster Wheel option was made available for chisel implements.
- 2012 – 41', 46' & 53' Trail Type Landroller added to product line. Additional Superchisel sizes of 16' & 20' were added.
- 2013 – DT9530 added to product line. Internal Scraper in Rolling Baskets introduced. Finishing Coulter Gang becomes standard on the Diamond Disk and 2510 DT. Corporate offices opened at Devils Lake plant. New building and location for the Aberdeen warehouse.
- 2014 – Introduced the VRT2530 (Variable Rate Tillage).
- 2015 – Introduced the VT Flex Applicator and Spray Fill Xpress.

Summers distributes on a wholesale level to dealers and distributors throughout markets in North Dakota, South Dakota, Minnesota, Montana, Iowa, Washington, Idaho, Oregon, Utah, Colorado, Kansas, Nebraska, Oklahoma, Texas, Manitoba, Saskatchewan, Alberta, British Columbia, Kazakhstan, Russia and Australia, making it an international company.

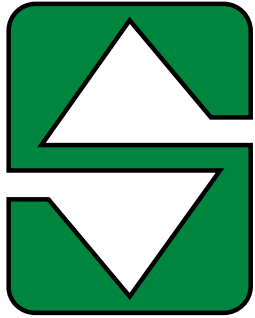

SUMMERS[®]

... Field Tested TOUGH!



Tillage



Rock Picker



Land Rollers/Packers



Cultivators/Harrows



Mounted Attachments



Sprayers

